

# Mine Rescue Team Training Metal and Nonmetal Mines



U.S. Department of Labor  
Mine Safety and Health Administration  
National Mine Health and Safety Academy

MSHA 3027 (Formerly IG 6)

Revised 2008



**Visit the Mine Safety and Health Administration  
website at [www.msha.gov](http://www.msha.gov)**

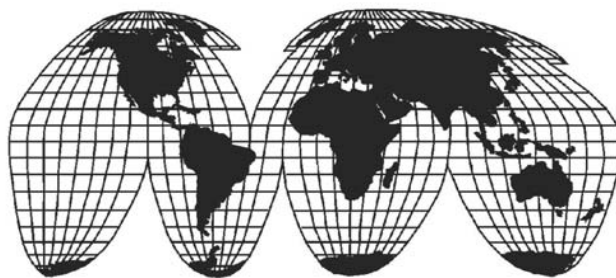

# **CONTENTS**

Introduction

Your Role as an Instructor

Overview

Module 1 – Surface Organization

Module 2 – Mine Gases

Module 3 – Mine Ventilation

Module 4 – Exploration

Module 5 – Fires, Firefighting, and Explosions

Module 6 – Rescue of Survivors and Recovery of Bodies

Module 7 – Mine Recovery

Module 8 – Mine Rescue Training Activities

## Introduction

Throughout history, miners have traveled underground secure in the knowledge that if disaster strikes and they become trapped in the mine, other miners will make every possible attempt to rescue them. This is the mine rescue tradition.

Today's mine rescue efforts are highly organized operations carried out by groups of trained and skilled individuals who work together as a team.

Regulations require all underground mines to have fully-trained and equipped professional mine rescue teams available in the event of a mine emergency.

MSHA's Mine Rescue Instruction Guide (IG) series is intended to help your mine to meet mine rescue team training requirements under 30 CFR Part 49. The materials in this series are divided into self-contained units of study called "modules." Each module covers a separate subject and includes suggestions, handouts, visuals, and text materials to assist you with training.

Instructors and trainers may wish to use these materials to either supplement existing mine rescue training, or tailor a program to fit their mine-specific training needs.

Since regulations, policy and mining technology can change, be sure to check for information that could supersede this material. Visit MSHA's website at <http://www.msha.gov> for additional information and updates.

## Your Role as an Instructor

You are about to assume an important responsibility – that of building and maintaining a capable mine rescue team. What your team members learn during these training sessions could very well help to save their lives and the lives of their fellow miners.

Keep this in mind as you proceed: be sure to let your trainees know that this program has been developed with their health and safety in mind.

These training materials are as complete and self-contained as possible. Study the module before teaching the class so that you'll be familiar with the material. Also, take time to review applicable regulations. Be flexible: take time to tailor the material to your team's needs.

Remember, the key to effective instruction is to be familiar and comfortable with the content.

## Overview

As part of the mine rescue series, this guide contains training modules designed to help instructors provide advanced/refresher mine rescue team training required under 30 CFR Part 49 for metal and nonmetal mines.

The modules in this IG include:

- Surface Organization
- Mine Gases
- Mine Ventilation
- Exploration
- Fires, Firefighting, and Explosions
- Rescue of Survivors and Recovery of Bodies
- Mine Recovery
- Mine Rescue Activity Book

The modules are organized exactly the same way to help guide you logically through the lessons. Each module includes:

- Training Objectives
- Course Materials
- Notes To Trainer
- Instructional Text
- Suggested Training Activities
- Visuals and Handouts
- Demonstration Checks
- General Review Questions
- Glossary

**NOTE TO TRAINER:** Take time to thoroughly review objectives and materials in each section *before* you conduct training activities. Remember to **always** comply with the manufacturer's recommendations use care, maintenance, and wearing of an SCBA.

**A Guide to  
Mine Rescue Training –  
Metal and Nonmetal**

**Surface Organization**

**Module 1**

## Table of Contents

Course Objectives .....	1-1
Course Materials .....	1-1
Course Outline .....	1-2
Instructor Notes and Suggested Lecture .....	1-3
Visuals.....	1-11
Glossary .....	1-14

# Course Objectives

## Main Objective

The mine rescue team will be able to identify the components of an effective mine rescue and recovery surface organization and the role the team plays in this structure.

## Supportive Objectives

Team members will:

- Become familiar with the mine's emergency notification plan.
- Understand the importance of establishing a chain-of-command and identify the team's place in this chain.
- Identify various facilities and arrangements normally recommended for carrying out a rescue and recovery operation.
- Identify the various personnel and duties normally involved in surface organization.

# Course Materials

Required:

- Handouts and visuals from the back of this module
- Pencil and paper for each team member

Suggested:

- Mine's Notification Plan
- Laptop computer
- PowerPoint program
- Chalkboard or flipchart



# Course Outline

- I. The Mine's Emergency Notification Plan
- II. Surface Arrangements
  - A. Suggested facilities and services
    - 1. Command center
    - 2. Waiting area for teams
    - 3. Bench area for apparatus
    - 4. Security
    - 5. Information center
    - 6. Waiting area for families and friends
    - 7. Press room
    - 8. Food and sleeping quarters
    - 9. Laboratory
    - 10. Medical facilities
    - 11. Temporary morgue
- III. Establishing a Chain-of-Command
- IV. Other key personnel and their responsibilities
  - 1. Mine superintendent
  - 2. Mine foreman
  - 3. Mine clerk
  - 4. Chief electrician
  - 5. Chief mechanic or mechanical foreman
  - 6. Outside foreman
  - 7. Safety director
  - 8. Chief engineer
  - 9. Supply clerk
  - 10. Other company personnel

# Instructor Notes and Suggested Lecture

## The Mine's Emergency Notification Plan

Each mine must have an Emergency Notification Plan for notifying necessary personnel when there is an emergency at the mine. This plan lists the various supervisors, administrators, and government officials who must be notified in case of an emergency.

Federal regulations require mines to have and post a Mine Rescue Notification Plan for notifying all the mine rescue team members that will be needed to assist in the rescue and recovery operation (**30 CFR Section 49.9**).

The mine's notification plan should also include any other people or services that will be needed at the mine site such as police officers, supply clerks, telephone operators, medical personnel, ambulances and other emergency vehicles.

**NOTE TO TRAINER:** Show the team a copy of their mine's notification plan, if there is one available. Or you can use the sample emergency notification plan (Visual 1).

## Surface arrangements

Surface arrangements cover a wide range of activities and require the coordinated efforts of many people. They include such tasks as establishing a command center where all the decisions are made, providing an adequate information center from which all public information is released, and obtaining and distributing necessary supplies and equipment.

### Command Center

The Command Center is the hub of rescue and recovery operations and is typically staffed and controlled by a mine emergency "command group." This group is generally comprised of mine management personnel, federal and state officials, and union representatives.

The Command Center receives a tremendous amount of information and will require secure communications equipment connected to underground phones and to other surface phones; this will enable the command group to communicate vital information during the rescue/recovery operations.

All decisions concerning the mine rescue teams (scheduling, assignments, tracking, rotations, and methods of exploration or firefighting are made by the Command Center. The decision process of the command group is sometimes time-consuming, but it is important to understand the impact a single decision will have on the entire operation. A hasty or wrong decision could mean disaster and the loss of life.

## **Security**

Having good security at the mine is important in order to keep the roads open and to ensure that curious bystanders do not hinder the mine rescue effort and are not injured while on the mine property.

Incoming traffic on the roads leading to the mine property should also be regulated by authorized personnel to keep unnecessary vehicles off the roads so that they can remain open for needed personnel, supplies, and emergency vehicles.

## **Waiting Area for Teams**

When the teams arrive at the mine site, they should be checked in and assigned to a team area. The mine rescue team coordinators should develop a “rotation schedule” for the deployment of all teams called to the mine site.

**NOTE TO TRAINER:** The rotation schedule should be designed so there is a clear working order and backup teams always available. Time should be allotted for teams to rest and to clean, test, and prepare their apparatus and other equipment. Refer to Visual 2 at the back of this module for a sample rotation schedule.

## **Bench Area for Apparatus**

An area that has work benches and where water is available should be set aside as an apparatus room where the apparatus can be cleaned, tested, and prepared for use by the bench person or by the team members.

## **Food and Sleeping Quarters**

Arrangements for food and sleeping quarters should be made for all personnel at the mine. Usually, food is brought in and rooms at a nearby motel are reserved. If there aren't any nearby motels, arrangements should be made for sleeping quarters at the mine.

## **Laboratory**

If it will be necessary to test samples of the mine air during the rescue and recovery operation, a laboratory with suitable air analysis equipment should be set up at the mine for testing such air. If this is not possible, the air samples may have to be sent to an off-site laboratory for analysis.

## **Medical Facilities**

Arrangements for medical services and facilities should be made. This could range from standby ambulances and a first-aid room to a temporary hospital, depending on the nature of the emergency.

## **Communicating Information Related to the Emergency**

An information center (which is directed by the Command Center group) should be established on the surface to release information related to the emergency to families and the public.

The information center must be secured, staffed, and controlled by authorized personnel only. It is **crucial** that information related to the emergency be controlled, communicated, and disseminated appropriately.

## **Liaison Function**

The liaison function serves to maintain a point-of-contact between the Command Center Group and other concerned parties such as:

- Family Members
- Mining Company Representatives
- Legal Representatives
- Local Officials
- Property Owners
- News Media

**NOTE TO TRAINER:** Section 7(3) of the MINER Act of 2006 requires that in such accidents, that the Mine Safety and Health Administration will serve as the primary communicator with the operator, miners' families, the press and the public.

## **Relaying Information to Family Members**

A special room will usually be set aside as a waiting room for the families and friends of any trapped or otherwise involved miners. They should be kept informed as to the progress of the rescue and recovery operation with hourly or periodic progress reports issued from the information center.

## **Press Room**

An area completely separate from the family waiting area should be set up as a press room, where media representatives can gather to receive the news releases issued from the information center.

## **Establishing a Chain-of-Command**

A great number of people will be doing many different jobs during a rescue and recovery operation. Therefore, it is important to establish a clear chain-of-command so that rescue and recovery work can be well coordinated.

Located at the top of the chain-of-command is the mine superintendent or a designated responsible person who delegates duties to other people. These people must know exactly what their duties and responsibilities are, who to report to, and who reports to them.

State and Federal officials will arrive at the mine site to advise and observe. Federal officials can take charge of an operation if they deem it necessary, but normally their role is to consult with and advise the company personnel on how the rescue and recovery work might best be carried out safely.

The team is under the direct supervision of the team captain. The captain also works and communicates with the designated official(s) who are responsible for coordinating the work carried out by mine rescue teams.

Mine rescue teams must receive accurate, concise, and reliable briefing information from the Command Center to perform rescue/recovery duties in a safe, timely, and efficient manner. The teams will also need up-to-date mine maps for exploration duties.

It is extremely important to develop a standardized method of reporting gas readings and other critical information to the Command Center and the Fresh Air Base (FAB).

**NOTE TO TRAINER:** Emphasize the critical importance of maintaining communications between the team and the fresh air base.

## Other Key Personnel and Their Responsibilities

**NOTE TO TRAINER:** The following list suggests a sample break-down of personnel and various duties to be carried out during a mine emergency. As part of this training, you should review the emergency response plans and procedures in place at the mine(s) covered by your team.

**Mine Superintendent** – The mine superintendent (or other designated person) is normally in charge of the entire operation.

The mine superintendent or other designated person, as part of the mine emergency command group (Command Center), will likely oversee numerous aspects of rescue and recovery operations. The superintendent or designated person must be ready to delegate personnel to:

- Notify the families of any trapped miners (which should be done in person, if possible).
- Notify the families of any miners or other personnel who have been authorized to stay at the mine site as emergency operations personnel.
- Monitor the underground communications continuously, regardless of whether or not it appears to be operational.
- Obtain gas samples from the main returns.

**Mine Foreman** – Duties of the mine foreman may include the following:

- Organize underground operations for each shift in cooperation with the person in charge, Federal inspectors, and, if involved, state inspectors and union representatives.
- Provide suitable transportation for people and supplies, as needed.

**Mine Clerk** – The duties of a mine clerk may include the following:

- Notify all persons on the notification plan and inform them of the emergency.
- Attend the telephone at the Command Center.
- Assign people for errand duty.

**Chief Electrician** – Duties of the chief electrician may include the following:

- Pull and immediately lock all electric switches controlling the electricity to the mine, when authorized by the person in charge.
- Provide materials for additional telephone communications as needed.
- Arrange for any needed assistants.

**Chief Mechanic or Mechanical Foreman** – Duties of the chief mechanic may be:

- Check explosion doors (for exhausting fan) or weak wall (for blowing fan) for damage. Make sure explosion doors are closed or weak wall is repaired.
- Check fan, and, if necessary, instruct an electrician or machinist to make repairs to the fan.
- Monitor the operation of the fan and the atmosphere in and around the fan house if the fan is exhausting.
- With an exhausting fan, proper precautions should be taken to avoid asphyxiation or an explosion in the fan house.

**Outside Supervisor** – Duties of an outside supervisor may include:

- Arrange for guards and state and/or local police to:
  - Rope off and guard all mine openings.
  - Guard all roads and paths leading to the mine.
- Designate a check person to monitor people entering and leaving the mine. The check person should:
  - Attend to assigned station within the roped-off area.
  - Allow no one to go underground except persons authorized by the officials in charge.
  - Examine each person (entering the mine) for matches and smoking materials, making no exceptions.
  - Check off each person by name and number and record the time as they go in and come out of the mine.
- Set up an area where food and drinks are available for the rescue teams and other personnel.
- Set up medical facilities and make arrangements for sleeping quarters.

**Safety Director** –Duties of the mine’s safety may be to:

- Assemble mine rescue teams and first-aid crews.
- Provide facilities and equipment for testing, cleaning, and recharging the breathing apparatus.
- Assign personnel to issue, record, and return mine rescue equipment.
- Consult with the mine manager or superintendent regarding plans for rescue and recovery operations.

**Chief Engineer** – The chief engineer may include the following:

- Provide copies of up-to-date maps showing the regular flow of air and the location of ventilation controls, doors, pumps, substations, machinery, and the electrical system (with control switch locations).
- Alert adjoining mines if they are connected underground with the affected mine.
- Obtain maps of adjoining mines.
- Make arrangements to furnish drilling rig equipment, if needed.

**Supply Clerk** – A supply clerk may be responsible for the following duties:

- Obtain and distribute all equipment, supplies, and non-sparking tools used for the operation.
- Prepare an inventory of existing equipment and supplies.
- Contact other mines and suppliers to obtain other needed supplies and equipment.
- Have ready for immediate use: nails, brattice cloth, hatchets, axes, saws, picks, boards, telephones, wires, any needed gas testing equipment, sledge hammers, slate bars, shovels, suitable roof supports, lifting jacks, stretchers, batteries, and first-aid cabinets.
- Provide coveralls, safety shoes, gloves, caps, flashlights, safety glasses, and lamp belts.
- Keep a record of all equipment issued and returned.



[This Page Intentionally Left Blank]

**Suggested Mine Emergency Notification Plan**  
**Remove Underground Workers Immediately**  
**Notify at Once**

	Name	Address	Telephone (Home)	Telephone (Office)
1. Mine Manager				
2. Mine Superintendent				
3. Mine Supervisor				
4. Safety Director				
5. General Mine Manager				
6. General Mine Superintendent				
7. District Inspector (State and Federal)				
8. Chief, State Department of Mines				
9. District MSHA Office				
10. District Office of Miner's Union				
11. Law Enforcement Agencies				
12. Medical Personnel, Ambulances, and Other Emergency Vehicles				
13. Hospital to be Alerted				

**Visual 1**

[This Page Intentionally Left Blank]

## SAMPLE SIX-TEAM ROTATION SCHEDULE (24-Hour Period)

Team No. and Captain	Two-Hour Time Periods															
	1	2	3	4	5	6	7	8	9	10	11	12				
1	Work	R	R	Standby	R	Standby	Standby	Standby	Backup at FAB	Work	R	R	Standby	Standby	Standby	Backup at FAB
2	Backup at FAB	Work	R	Standby	R	Standby	Standby	Standby	Standby	Backup at FAB	R	R	R	Standby	Standby	Standby
3	Standby	Backup at FAB	Work	R	Standby	R	R	Standby	Standby	Standby	Work	R	R	R	Standby	Standby
4	Standby	Standby	Standby	Backup at FAB	Standby	Work	R	R	Standby	Standby	Backup at FAB	Standby	Work	R	R	R
5	R	Standby	Standby	Standby	Standby	Backup at FAB	Work	R	Work	R	Standby	Standby	Backup at FAB	Work	Work	R
6	R	R	R	Standby	Standby	Standby	Standby	Standby	Standby	Work	Standby	Standby	Standby	Standby	Backup at FAB	Work

**Note:** This schedule is a sample of how six teams could be rotated during a 24-hour period. If a larger number of teams are available, the schedule of rotation would, of course, be different.

R = Reserve                      FAB = Fresh Air Base

## Visual 2

## Glossary

**Backup team** – The rescue team stationed at the fresh air base as a “backup” for the working team beyond the fresh air base.

**Bench area** – An area where apparatus is cleaned, tested, and prepared for use.

**Chain-of-command** – Order of authority and division of responsibilities among personnel.

**Command center** – Headquarters for the rescue and recovery operation.

**Fresh air base** – Base of operations from which the rescue and recovery teams can advance into irrespirable atmospheres.

**Notification plan** – Plan for notifying necessary personnel when there is an emergency at the mine.

**Rotation schedule** – Schedule that establishes a clear order of team usage during a rescue and recovery operation.

**Standby team** – Team scheduled to be on the surface in ready reserve when rescue teams are working underground.

**Triage** – System of assigning priorities of medical treatment to injured persons.

**A Guide to  
Mine Rescue Training –  
Metal and Nonmetal**

**Mine Gases**

**Module 2**

## Table of Contents

Course Objectives .....	2-1
Course Materials .....	2-1
Course Outline .....	2-2
Instructor Notes and Suggested Lecture .....	2-3
Visuals.....	2-31
General Review.....	2-69
Glossary .....	2-73

# Course Objectives

## Main Objective

The mine rescue team members will identify the physical properties and characteristics of gases they may encounter during rescue and recovery work. They will identify where the gases are normally found, how to test them, and the meanings of their findings.

## Supportive Objectives

Team members will:

- Identify the meaning of these terms: Specific gravity, explosive range, toxicity, asphyxiate, and solubility.
- Identify the physical properties and characteristics of each gas they may encounter following a fire, explosion, inundation, or other disaster, identify where such gases might be found, how to detect them, and explain the meanings of their findings.
- Identify the composition, physical properties, and characteristics of smoke, rock strata gases, and the damp.

# Course Materials

Required:

- Handouts and visuals from the back of this module
- Pencil and paper for each team member
- Gas detecting equipment and devices the team will use to test gases they encounter in the mine, and the manufacturer's instructions
- Mine Rescue Activity Book

Suggested:

- Evacuated bottle or syringe for taking air samples
- Laptop computer
- PowerPoint program
- Chalkboard or flipchart



# Course Outline

- I. Introduction
  - A. Gas detection
  - B. Gas detector requirements
  - C. Portable gas detectors
  - D. Air sampling and chemical analysis
  
- II. Basic gas principles
  - A. Description
  - B. Diffusion of gases
    - 1. Atmospheric pressure and its effects on rate of diffusion
    - 2. Temperature and its effects on rate of diffusion
    - 3. Specific gravity or relative weight
  - C. Explosive range and flammability
  - D. Solubility
  - E. Color/odor/taste
  - F. Health hazards
    - 1. Toxic gases
    - 2. Asphyxiating gases
  
- III. Mine gases and their detection
  - A. Normal air
  - B. Oxygen
  - C. Nitrogen
  - D. Carbon dioxide
  - E. Carbon monoxide
  - F. Oxides of nitrogen
    - 1. Nitric oxide
    - 2. Nitrogen dioxide
  - G. Hydrogen
  - H. Hydrogen sulfide
  - I. Sulfur dioxide
  - J. Methane
  - K. Heavy hydrocarbons
    - 1. Ethane
    - 2. Propane
    - 3. Butane
  - L. Acetylene
  - M. Radon
  
- IV. Smoke
  
- V. Rock-strata gases
  
- VI. The damps

# Instructor Notes and Suggested Lecture

## Introduction

Under normal conditions, many gases are present in a mine. The mine's ventilation system is designed to bring in fresh air to disperse and remove harmful gases and to supply oxygen. During a disaster, however, the situation may be quite different. Fires or explosions may release dangerous gases into the atmosphere. A disrupted ventilation system could result in an oxygen-deficient atmosphere and/or a buildup of toxic or explosive gases.

**Note:** Because of the large diversity of minerals and ores mined in metal and nonmetal mines and the diversity of mining techniques used, terminology will vary somewhat from operation to operation. The mining terminology used in this training module may or may not agree completely with the terms used in your area. It may be necessary, therefore, for you to adapt and change some of the terminology to suit the needs of your team. For example, in some mines, the term "back" (used throughout this module) will have to be changed to "roof."

## Gas Detection

Gas detection is an important part of any rescue or recovery operation. Your team will make frequent tests for gases as it advances beyond the fresh air base. For your own safety, you'll want to know what harmful gases are present, how much oxygen is in the atmosphere, and whether or not gas levels are within the explosive range.

Knowing what gases are present and in what concentrations provides you with important clues as to what has happened in the mine. Test results can also give you an idea about existing conditions.

For example, if you get carbon monoxide (CO) readings, there's probably a fire. The amount of carbon monoxide indicates something about the extent of that fire.

## Gas Detector Requirements

MSHA requires mine rescue stations serving underground M/NM mines to have four gas detectors appropriate for each gas which may be encountered at the mines served. In addition, gas detectors must measure concentrations of methane from 0.0 percent to 100 percent of volume, oxygen from 0.0 percent to at least 20 percent of volume, and carbon monoxide from 0.0 parts per million to at least 9,999 parts per million. **[30 CFR 49.6(a)(6)].**

You may wish to mention that any testing device containing electrical circuits, such as methane detectors, used in mines classified as gassy must be “permissible.” This means that MSHA has tested the devices and found them safe for use under such conditions.

## **Portable Gas Detectors**

Portable gas detectors include such devices as carbon monoxide (CO) detectors, multi-gas detectors used in conjunction with various tubes, and methane monitors used in mines with methane. The team uses these devices to test the mine air repeatedly as it advances beyond the fresh air base.

**NOTE TO TRAINER:** Show the team the portable gas detectors they’ll be using and/or refer to Visual 1 for some commonly used portable gas detectors. You may use this visual as a PowerPoint, chalkboard sketch, or handout.

## **Air Sampling and Chemical Analysis**

Another way to test for gases is to collect air samples in special syringes, evacuated bottles (bottles from which air has been removed) or gas or liquid displacement containers. These samples are then sent to a laboratory for chemical analysis. Chemical analysis is also sometimes performed at the mine site with portable equipment.

**NOTE TO TRAINER:** Show the team a syringe or evacuated bottle, and/or refer to Visual 2 that shows a syringe used to collect air samples. You may use this visual as a PowerPoint, chalkboard sketch, or handout.

Chemical analysis is generally a more time-consuming process than testing with a portable device, but its advantage is accuracy. It tells exactly what gases the sample contains, and in precisely what amounts. A complete chemical analysis can also reveal the presence of gases that portable detectors are not designed to detect.

Air samples aren’t taken as often as portable detector readings, but they’re still an important part of rescue and recovery operations. For example, you may be required to take air samples from ventilation shafts and exhaust airways. This method is often used to get information about existing conditions prior to sending teams underground. Air samples taken from behind sealed areas of the mine are analyzed to determine when it’s safe to begin recovery work.

## Basic Gas Principles

In order to test for gases and to understand what the test readings mean, you should first know a little about the characteristics and properties of gases. After we've discussed these general principles, we'll talk about specific gases you may encounter during rescue and recovery work.

### Description

To help you understand what a gas is, let's compare it with a liquid and a solid. A solid has a definite shape and volume. A liquid has a definite volume, but changes shape according to the shape of its container. However, a gas is a substance with neither a definite shape nor volume. It expands or contracts to fill the area in which it's contained.

### Diffusion of Gases

The volume of a gas changes in response to any change in atmospheric pressure or temperature. For example:

- An increase in pressure causes a gas to contract.
- A decrease in pressure causes a gas to expand.
- An increase in temperature causes a gas to expand.
- A decrease in temperature causes a gas to contract.

The gas's rate of diffusion is also affected by the ventilating air currents in the mine. The rate of diffusion is greatly increased by higher velocities of air currents or by turbulence in the air.

Knowing the effects of air current, temperature, and pressure on a gas will help you determine its rate of diffusion. The rate of diffusion is how quickly the gas will mix or blend with one or more other gases and how quickly it can be dispersed.

### Atmospheric Pressure and its Effects on Rate of Diffusion

Pressure exerted on a gas is usually atmospheric pressure. Atmospheric pressure is measured on a barometer. A rise in the barometric reading indicates an increase in pressure. A drop in barometric reading indicates a decrease in pressure. The atmospheric pressure varies within a mine, just as it does on the surface.

**NOTE TO TRAINER:** Refer to Visual 4 for an illustration of the effects of atmospheric pressure on a gas. You may use this visual as a PowerPoint, chalkboard sketch, or handout.

Atmospheric pressure affects the diffusion rate of a gas. For example, if the barometer rises, indicating increased pressure, gas responds by contracting. A gas that's squeezed into a smaller area like this is more concentrated, so it diffuses more slowly. It's much easier for concentrations of explosive gases to build up when the barometric pressure is high.

On the other hand, when barometric pressure falls, the pressure on the gas is reduced. The gas responds by expanding. Once the gas expands, it is less concentrated, so it diffuses more quickly.

## **Temperature and its Effects on Rate of Diffusion**

It's important to understand how temperature affects the rate of diffusion of a gas. High temperatures (or heat) cause gases to expand, so they diffuse more quickly. Consequently, heat from a fire in the mine will cause gases to expand and be dispersed more easily. Lower temperatures work the opposite way: Gases respond to cold by contracting and by diffusing more slowly.

**NOTE TO TRAINER:** Refer to Visual 5 for an illustration of the effects of temperature on a gas. You may use this visual as a PowerPoint, chalkboard sketch, or handout.

## **Specific Gravity or Relative Weight**

Specific gravity is the weight of a gas compared to an equal volume of normal air under the same temperature and pressure. (This is also referred to as "relative weight.") The specific gravity of normal air is 1.0. The weight of air acts as a reference point from which we measure the relative weight of other gases. For example, a gas that is heavier than air has a specific gravity higher than 1.0. A gas that is lighter than air will have a specific gravity less than 1.0.

If you know the specific gravity of a gas, you will know where it will be located in the mine and where you should test for it. Gases issuing into still air without mixing tend to stratify according to the gas's specific gravity. Light gases or mixtures tend to stratify against the back and heavy gases or mixtures tend to stratify along the floor.

Sulfur dioxide, for example, has a specific gravity of 2.2638. This is much heavier than normal air. Knowing this, you can predict that sulfur dioxide will collect in greater concentrations near the bottom or in low areas of a mine. This is why you test for sulfur dioxide in low areas of the mine.

If the weight of a gas you're testing for is lighter than normal air, you'll know to test for it near the back of the mine. That's because lighter gases tend to rise, so you can expect to find them in greater concentrations in high areas of the mine.

Besides helping you determine where to test for a gas, specific gravity also indicates how quickly the gas will diffuse and how easily it can be dispersed by ventilation. In still air, the ordinary process of diffusion is a very slow process. However, under usual mine conditions, ventilating air currents and convection currents produced by temperature differences cause a rapid mechanical mixing of gases with air. Once the gases are mixed, if the ventilating air currents remain constant, they will not separate or stratify again.

Light gases, such as hydrogen, diffuse rapidly and are fairly easy to disperse. Heavier gases such as sulfur dioxide and carbon dioxide do not diffuse rapidly, so they're more difficult to disperse. It's much easier to remove a concentration of a light gas like hydrogen by ventilation than it is to remove the same concentration of a heavier gas like sulfur dioxide.

**NOTE TO TRAINER:** Refer again to Visual 3 and Visual 4 as you review the effects of temperature and pressure on rate of diffusion. Use these visuals as a PowerPoint, chalkboard sketch, or handout.

Specific gravity is not the only factor that determines how quickly a gas will diffuse or disperse. Temperature and pressure also affect it. An increase in temperature makes a gas diffuse more rapidly. A decrease in temperature slows down the rate of diffusion. Atmospheric pressure works just the opposite: An increase in pressure slows down the rate of diffusion. A decrease in pressure speeds it up.

## **Explosive Range and Flammability**

A gas that will burn is said to be "flammable." Any flammable gas can explode under certain conditions. In order for a flammable gas to explode, there must be enough of the gas in the air, enough oxygen, and a source of ignition.

The range of concentrations within which a gas will explode is known as its "explosive range." Figures representing the higher and lower limits of the explosive range are expressed in percentages.

The amount of oxygen that must be present for an explosion to occur is also expressed as a percentage. When the necessary oxygen concentration approaches that found in normal air, the level is expressed simply as "normal air." The explosive range of hydrogen, for example, is 4.0 to 74.2 percent in the presence of normal air.

## **Solubility**

Solubility is the ability of a gas to be dissolved in water. Some gases found in mines are soluble and can be released from water. Sulfur dioxide and hydrogen sulfide, for example, are water-soluble gases. Both may be released from water.

Solubility is an important factor to consider during recovery operations. When a mine is sealed off for any length of time, water can collect in it. This water may have occurred naturally, or it may have been introduced during firefighting. Whatever the case, pools of water can release water-soluble gases into the air when they are stirred up. Pumping water from such pools, or walking through them, can release large amounts of soluble gases which would not otherwise be found in the mine atmosphere.

### **Color/Odor/Taste**

Color, odor, and taste are physical properties that can help you identify a gas, especially during barefaced exploration. Hydrogen sulfide, for example, has a distinctive “rotten egg” odor. Some gases may taste bitter or sour; others sweet. The odor of blasting powder fumes, together with a reddish-brown color, indicates there are oxides of nitrogen present.

Of course, you can't rely on only your senses to positively identify a gas. Only detectors and chemical analysis can do that. Many hazardous gases, such as carbon monoxide, have no odor, color, or taste. Keep these properties in mind as we discuss each gas you may encounter in the mine. One or more of these properties may be your first clue that a particular gas is present.

# Health Hazards

## Toxic Gases

Some gases found in mines are toxic (poisonous). This can refer either to what happens when you breathe the gas, or what happens when the gas comes into contact with exposed areas of your body.

**NOTE TO TRAINER:** Refer to Visual 7 as you discuss the factors that determine the effects of a toxic gas. Use this visual as a PowerPoint, chalkboard sketch, or handout.

The degree to which a toxic gas will affect you depends on three factors: (1) how concentrated the gas is, (2) how toxic the gas is, and (3) how long you're exposed to the gas.

**Note:** You may wish to mention that each toxic gas has a Threshold Limit Value (TLV), established by the government. TLVs denote average concentrations of gases to which workers are permitted to be exposed over an 8-hour daily period. The Threshold Limit Value of a gas is typically expressed in "parts per million" (PPM).

For example, the TLV for carbon monoxide (CO) is relatively low—50 PPM (or .005 percent). This means that the most CO you can be exposed to over an 8-hour daily period without harmful effects is 1/200 of one percent. That isn't much. The TLV for carbon dioxide (CO<sub>2</sub>) is higher—5,000 PPM (.500 percent). You can tolerate concentrations of up to ½ of 1 percent CO<sub>2</sub> over an 8-hour daily period without harmful effects.



Some toxic gases are harmful to inhale. A self-contained breathing apparatus (SCBA) will protect you from such gases, as long as your face-to-facepiece seal is tight and the unit is working properly. Other toxic gases harm the skin or can be absorbed by the skin. An SCBA won't protect you from such gases. If you wear your SCBA in petroleum-based fumes for prolonged or successive periods, the fumes can eventually permeate its rubber parts so that the apparatus no longer provides you with adequate protection. Your team may be forced to leave an area where such gases are detected.

## Asphyxiating Gases

“Asphyxiate” means to suffocate or choke. Asphyxiating gases cause suffocation. They do this by displacing oxygen in the air, thus producing an oxygen-deficient atmosphere. Since your self-contained breathing apparatus supplies you with oxygen, it will protect you against asphyxiating gases.

**Review Questions:** Ask the team members the following questions and allow time for them to answer. Then discuss the answers with them so they understand the material covered in this section.

1. How do temperature and pressure affect a gas, and how do these factors affect mine rescue?

Temperature increases cause expansion. Temperature decreased cause contraction. Pressure increases cause contraction. Pressure decreases cause expansion. Implication: These factors affect the diffusion rate of gases in the mine.

2. What is specific gravity?

The specific gravity (or relative weight) of a gas is its weight in relation to an equal amount of normal air under the same temperature and pressure.

3. What can you determine if you know the specific gravity of a particular gas?

Specific gravity determines where the gas will stratify in still air in the mine (whether it will rise or fall). It also determines how easily a gas can be diffused or flushed out of the mine by ventilation.

4. What is the explosive range of a gas and why is it important for rescue team members to know the explosive range of gases they encounter?

The explosive range of a gas is the concentrations within which a flammable gas can explode when there is a specific amount of oxygen present. It's important for you to know the explosive ranges of gases you encounter and the amount of oxygen necessary for an explosion so you will immediately know when you encounter a potentially explosive atmosphere.

5. What is a toxic gas?

A gas that is poisonous.

6. How can you protect yourself from toxic gases?

Wearing a self-contained breathing apparatus (SCBA) will protect you from many of them. However, an SCBA does not provide you with protection against gases that attack the skin or enter the body through the skin. Neither will it provide protection if you wear it for prolonged or successive periods in petroleum-based fumes, because such fumes may permeate the rubber. In the presence of such gases, your team may be forced to leave the area of the mine where they're located.

7. How does an asphyxiating gas produce an oxygen-deficient atmosphere?

By displacing oxygen.

8. How do you protect yourself in an oxygen-deficient atmosphere?

Wear an SCBA, which supplies you with oxygen.

9. Why is it important for you to know about the solubility of certain gases in water?

Gases dissolved in water can be liberated in large quantities when mine rescue teams disturb the water by walking through it, or by beginning pumping operations.

10. Why should you know about the characteristic color, odor, and taste of gases you may encounter?

The characteristic color and, if the team is barefaced, odor or taste of a gas may be the first clue a rescue team has that the gas is present in the mine atmosphere.

# Mine Gases and Their Detection

## Normal Air

**NOTE TO TRAINER:** Refer to Visual 8 for a pie chart showing the composition of normal air. Use this visual as a PowerPoint, chalkboard sketch, or handout.

The air we breathe is actually a mixture of gases. Clean, dry air at sea level is made up of 78 percent nitrogen and 21 percent oxygen. The remaining one percent is made up of argon, carbon dioxide, and small traces of other gases.

Other gases in air are: neon, helium, krypton, xenon, hydrogen, methane, nitrous oxide, and ozone.

Air is normally colorless, tasteless, and odorless. It supplies us with the oxygen necessary for life. However, during the day-to-day operations of a mine, normal air can become contaminated. For example, the carbon dioxide and water vapors miners exhale during respiration are contaminants.

Forces exerted on the mine's back, side, floor, and face during blasting may allow trapped gas pockets to escape into the mine air. Blasting may also produce pollutants such as carbon monoxide, hydrogen sulfide, and oxides of nitrogen. Even internal combustion engines and battery-charging stations can be sources of contamination because they can produce hazardous fumes. Normally these contaminants are carried away by the mine's ventilation system. But during a disaster situation, the mine's ventilation system may be partially or totally disrupted.

Fires and explosions can disrupt ventilation by damaging ventilation controls. Falls and rock bursts can disrupt ventilation by obstructing the flow of air. In addition, the disaster itself may provide additional sources of contamination. Fires and explosions, for example, often produce dangerous gases. Inundations may release water-soluble gases.

The gases present in a mine following a disaster will vary according to the type of mine and the disaster situation. The type of equipment used in the mine (electrical, compressed air, or diesel) will also affect which gases are present. However, for all mines, rescue teams **must** know how to test for oxygen deficiency and carbon monoxide.

In addition to this, the teams may have to know how to test for hydrogen sulfide, oxides of nitrogen, and so on. You should know how to test for all the gases that may be present in the mines in which you will be working as a mine rescue team.

**Note:** Information on several common mine gases is included in the following section. You may omit information pertaining to gases your team will not encounter in the mine or mines they'll be working in. On the other hand, if the team may encounter a gas that's not included here, be sure to supply them with information on that gas.

**Gas detection equipment note:** Since there are so many different types of gas detectors in use, this module does not provide information on the operation and maintenance of specific testing devices. Refer to the manufacturer's instructions packed with each device for that information. As you discuss the type of gas a particular device detects, show the team the equipment and explain how to use it. It's suggested that you discuss maintenance of the gas-testing equipment only after you've discussed all the gases the team may encounter.

**NOTE TO TRAINER:** Distribute copies of Visuals 9 and 10 handouts. These two charts contain basic information about mine gases and detection methods. Refer to them as you discuss specific gases throughout this section. You may also wish to use these charts as a PowerPoint or write the information on a chalkboard. This module also provides individual visuals for some of the main gases you'll be discussing (see Visuals 11 through 18). These charts are designed to be reproduced and distributed to the team members as handouts.

If you would like to make similar charts for any of the other gases you'll be discussing, use Visual 19 (sample fill-in gas chart) as a guide. Fill in the chart(s) as needed with the correct information.

## Oxygen (O<sub>2</sub>)

**NOTE TO TRAINER:** Distribute copies of the Visual 11 handout and refer to it as you discuss the properties and characteristics of oxygen. You may also use this visual as a PowerPoint or write the information on a chalkboard.

Specific Gravity. 1.1054

Explosive Range and Flammability. Oxygen is not an explosive gas, but it does support combustion.

Health Hazards. Oxygen found in normal air is nontoxic. In fact, it is essential for life. It is harmful to breathe air that is low in oxygen, and breathing extremely oxygen-deficient air can kill you.

For example, you're accustomed to breathing air containing about 21 percent oxygen. When the oxygen content of air drops to about 17 percent, you'll begin to breathe faster and deeper because your body is trying to compensate for the lack of oxygen. A 15 percent concentration will cause dizziness and headaches. If the oxygen content of the air you're breathing drops as low as 9 percent, you may lose consciousness. A 6 percent concentration or less is almost always fatal.

There are four main causes of oxygen deficiency in the mine: (1) insufficient or improper ventilation which fails to bring enough oxygen to the work area, (2) displacement of the air's oxygen by other gases, (3) a fire or explosion that consumes oxygen, and (4) consumption of oxygen by workers.

Solubility. Moderately soluble in water.

Color/Odor/Taste. Colorless, odorless, and tasteless.

Cause or Origin. Oxygen is the second largest component of normal air. About 21 percent of normal air is oxygen.

Detection Methods. Modern electronic oxygen indicators are used to detect oxygen-deficient atmospheres. Since oxygen is only slightly heavier than air, hold your portable detector at waist level when you test for oxygen deficiency. Chemical analysis will also detect oxygen deficiency.

When to Test. During exploration, test as often as necessary to determine whether the atmosphere is oxygen-deficient.

Meaning of Findings. If the main fan is still operating, an oxygen-deficient atmosphere could indicate that an explosion has taken place, or that a fire somewhere in the mine is consuming oxygen. Oxygen deficiency may also indicate that the mine's ventilation system has been disrupted.

## **Nitrogen (N<sub>2</sub>)**

Specific Gravity. 0.9674

Explosive Range and Flammability. Nitrogen is not an explosive gas and it will not burn.

Health Hazards. Nitrogen is nontoxic. However, in above-normal concentrations, it acts as an asphyxiant because it lowers the oxygen content of the air.

Cause or Origin. Normal air contains approximately 78 percent nitrogen, making nitrogen the largest component of normal air. Nitrogen can issue from the strata in some metal mines. Another source of nitrogen in underground mines is the detonation of explosives.

Where Found. Increased nitrogen levels are often present after explosives have been detonated.

Detection Method. Chemical analysis.

When to Test. Test for nitrogen when you suspect that the atmosphere is oxygen-deficient, and in abandoned or inactive workings where ventilation is inadequate. Also test for it in mines where nitrogen is known to issue from rock strata.

Meaning of Findings. An elevated nitrogen content indicates an oxygen-deficient atmosphere.

## **Carbon Dioxide (CO<sub>2</sub>)**

**NOTE TO TRAINER:** Distribute copies of the Visual 12 handout and refer to it as you discuss the properties and characteristics of carbon dioxide. You may wish to use this visual as a PowerPoint or write the information on a chalkboard.

Specific Gravity. 1.5291

Explosive Range and Flammability. Carbon dioxide will neither burn nor explode.

Health Hazards. Normal air contains about 0.03 percent carbon dioxide. When present in high concentrations (2 percent or higher), carbon dioxide causes you to breathe deeper and faster. Breathing air containing 5 percent carbon dioxide increases respiration 300 percent, causing difficult breathing. Breathing air containing 10 percent carbon dioxide causes violent panting and can lead to death.

Solubility. Carbon dioxide is soluble in water.

Color/Odor/Taste. Carbon dioxide is colorless and odorless. High concentrations may produce an acid taste.

Cause or Origin. Carbon dioxide is a normal component of air and is a product of complete combustion (burning). Oxidation and the decay of timbers also produce carbon dioxide. Carbon dioxide is also a by-product of the respiration (breathing) process. Fires, explosions, and blasting operations produce CO<sub>2</sub>. In some mines, it is liberated from the rock strata.

Where Found. Because it's relatively heavy, CO<sub>2</sub> will be found in greater concentrations along the floor and in low places in the mine. It also often shows up in abandoned workings, during fires, and after an explosion or detonation of explosives.

Detection Methods. You can use a carbon dioxide detector, a multi-gas detector, or chemical analysis to test for carbon dioxide. Because CO<sub>2</sub> tends to collect near the mine floor, hold your portable detector low.

When to Test. Test for CO<sub>2</sub> after a fire or explosion. Also test for it when you're entering an inactive area of the mine or reopening a sealed area.

Meaning of Findings. Elevated CO<sub>2</sub> readings may indicate that a fire or explosion has taken place somewhere in the mine. High readings may also indicate an oxygen-deficient atmosphere.

## **Carbon Monoxide (CO)**

**NOTE TO TRAINER:** Distribute copies of the Visual 13 handout and refer to it as you discuss the properties and characteristics of carbon monoxide. You may also use this visual as a PowerPoint or write the information on a chalkboard.

Specific Gravity. 0.9672

Explosive Range and Flammability. Carbon monoxide is explosive and flammable. Its explosive range in normal air is 12.5 to 74.2 percent.

Health Hazards. Carbon monoxide is highly toxic even in very low concentrations. Exposure to as little as .15 to .20 percent (1500 to 2000 ppm) CO is extremely dangerous.

Carbon monoxide is so toxic because it combines easily with your red blood cells (hemoglobin)—the cells that normally carry oxygen to your body's tissues. Once the cells have taken up CO, they no longer have the capacity to carry oxygen. It doesn't take much CO to interfere with your blood's oxygen-carrying capacity because the gas combines with hemoglobin 200 to 300 times more readily than oxygen.

The first symptom of carbon monoxide poisoning is a slight tightening across your forehead and possibly a headache. Carbon monoxide poisoning is cumulative over time. As you continue to be exposed to it, the poisoning effects build up accordingly. As little as 500 PPM (0.05 percent) can kill you in three hours. If you're exposed to a high CO concentration, you may experience very few symptoms before losing consciousness.

Solubility. Carbon monoxide is slightly soluble in water.

Cause or Origin. Carbon monoxide is a product of the incomplete combustion of any carbon material. It is produced by mine fires and explosions of gas.

Carbon monoxide is produced by the burning or detonation of explosives, and it is emitted from the exhaust of internal combustion engines.

**Note:** You may wish to mention that carbon monoxide is the deadly gas associated with automobile exhausts.

Where Found. Carbon monoxide is found during mine fires and after explosions or detonations of explosives. It can also usually be detected near internal combustion engines.

Detection Methods. Carbon monoxide can be detected by means of carbon monoxide detectors, multi-gas detectors, or by chemical analysis. Since CO is slightly lighter than air, hold your portable detector at chest level.

When to Test. During any team exploration, test as often as necessary to determine the atmosphere's CO content, especially if fire is suspected.

Meaning of Findings. The presence of CO above normal ambient levels for a continued period of time definitely indicates there is a fire somewhere in the mine.

## **Oxides of Nitrogen** **Nitric Oxide (NO)** **Nitrogen Dioxide (NO<sub>2</sub> or N<sub>2</sub>O<sub>4</sub>)**

**NOTE TO TRAINER:** Distribute copies of the Visual 14 handout and refer to it as you discuss the properties and characteristics of nitrogen dioxide. You may also use this visual as a PowerPoint or write the information on a chalkboard.

**Note:** Nitric oxide (NO) does not exist in large amounts in the air because it quickly combines with oxygen (oxidizes) to form nitrogen dioxide (NO<sub>2</sub>).

Specific Gravity. (NO<sub>2</sub>) – 1.5894

Explosive Range and Flammability. NO<sub>2</sub> will neither burn nor explode.

Health Hazards. Oxides of nitrogen are highly toxic. Breathing even small amounts will irritate your throat.

When mixed with the moisture in your lungs, oxides of nitrogen form acids that corrode your respiratory passages and cause them to swell. Often, such symptoms don't show up until several hours after you're exposed to the gas.

Exposure to .01 to .015 percent (100 to 150 ppm) can be dangerous for even short exposures, and .02 to .07 percent (200 to 700 ppm) can be fatal for short exposures.



If exposure has been severe, the victim may die, literally drowned by water that has entered the lungs from the body in an attempt to counteract the corrosive effects of the acids formed by the oxides of nitrogen.

Solubility. Very slight solubility in water.

Color/Odor/Taste. Oxides of nitrogen are colorless at low concentrations and become reddish-brown at higher concentrations. They smell and taste like blasting powder fumes.

Cause or Origin. Oxides of nitrogen are produced by burning and by the detonation and burning of explosives. They are also emitted from the exhaust of diesel engines. In the presence of electrical arcs or sparks, nitrogen in the air combines with oxygen (oxidizes) to form oxides of nitrogen.

Where Found. Because they're heavier than air, oxides of nitrogen tend to collect in low places in the mine. They can be found when electrical malfunctions produce arcs or sparks, and after blasting operations.

Detection Methods. To test for nitrogen dioxide, you can use a nitrogen dioxide detector, a multi-gas detector, or chemical analysis. Hold portable detectors low when you test for these relatively heavy gases. Their characteristic reddish-brown color may be another indication that there is nitrogen dioxide present.

When to Test. Test for oxides of nitrogen following a fire or explosion and after the detonation of explosives. Since diesel exhaust is a source of these gases, test in areas where diesel equipment is used.

Meaning of Findings. High NO<sub>2</sub> readings could indicate there has been a fire or that explosives are burning. Malfunctioning electrical equipment producing arcs or sparks could also be the source. If diesel equipment is causing the elevated NO<sub>2</sub> readings, that indicates ventilation is inadequate.

## Hydrogen (H<sub>2</sub>)

**NOTE TO TRAINER:** Distribute copies of the Visual 15 handout and refer to it as you discuss the properties and characteristics of hydrogen. You may also use this visual as a PowerPoint or write the information on a chalkboard.

Specific Gravity. 0.0695

Explosive Range and Flammability. Hydrogen is a highly explosive gas. Air containing 4 to 74.2 percent hydrogen will explode even when there is as little as 5 percent oxygen present. Very violent explosions are possible when air contains more than 7 to 8 percent hydrogen. The presence of small quantities of hydrogen greatly increases the explosive range of other gases.

Health Hazards. At high concentrations, hydrogen can replace oxygen in the air and act as an asphyxiant. The most hazardous aspect of hydrogen, however, is the fact that it is highly explosive.

Solubility. Not soluble in water.

Color/Odor/Taste. Colorless, odorless, and tasteless.

Cause or Origin. Hydrogen is produced by the incomplete combustion of carbon materials during fires and explosions. It may also be liberated when water or steam comes in contact with hot carbon materials during firefighting. Battery charging also produces hydrogen.

Where Found. You can expect to find hydrogen in the vicinity of battery charging stations, where explosives have been detonated, and after explosions. Hydrogen may also be detected during firefighting when either water or foam extinguishing methods are used. You can also expect to find hydrogen in an area that's been sealed to extinguish a fire. Because hydrogen is relatively light, it tends to collect in high places.

Detection Methods. Hydrogen can be detected with a multi-gas detector, or by means of chemical analysis. Hold portable detectors high.

When to Test: Test for hydrogen after any fire or explosion and near battery charging stations in the mine. Also test for it when water, water mists, or foam is used to fight fires.

Meaning of Findings. The presence of hydrogen could indicate that a fire or explosion has taken place. Firefighting with water or foam could also be producing the hydrogen. Elevated readings could also indicate that there is inadequate ventilation around battery charging stations.

## **Hydrogen Sulfide (H<sub>2</sub>S)**

**NOTE TO TRAINER:** Distribute copies of the Visual 16 handout and refer to it as you discuss the properties and characteristics of hydrogen sulfide. You may also use this visual as a PowerPoint or write the information on a chalkboard.

Specific Gravity. 1.1906

Explosive Range and Flammability. Hydrogen sulfide is flammable and explosive in concentrations from 4.3 to 45.5 percent in normal air. It is most explosive at 14.2 percent.

Health Hazards. Hydrogen sulfide is one of the most poisonous gases known. In low concentrations of .005 to .010 percent (50 to 100 ppm), hydrogen sulfide causes

inflammation of the eyes and respiratory tract. Slightly higher concentrations of .02 to .07 percent (200 to 700 ppm) can lead to bronchitis or pneumonia. Higher concentrations of .07 to .10 percent (700 to 1000ppm) can cause rapid unconsciousness, cessation of respiration, and death. And .10 to .20 percent 1000 to 2000ppm) or more can cause immediate death.

Solubility. Soluble in water.

Color/Odor/Taste. Hydrogen sulfide is colorless, has the odor of rotten eggs, and a slight sweetish taste.

Cause or Origin. Hydrogen sulfide is produced when sulfur compounds decompose. It is found in certain oil and gas fields and in some gypsum mines. It also may be liberated from methane feeders in mines with methane.

Hydrogen sulfide is often liberated when acid mine water corrodes metallic sulfides. It can also be released from mine water which contains the gas in solution. Heating sulfides in the presence of moisture (as in mine fires) may also produce the gas. Blasting in sulfide ores can also liberate hydrogen sulfide.

Where Found. Hydrogen sulfide is found in low places of the mine because it is a relatively heavy gas. It's also often found in pools of water. In some mines, it may be found near oil or gas wells. Hydrogen sulfide may also be detected during mine fires. Since it is a water-soluble gas, hydrogen sulfide is often liberated from water in sealed areas of the mine when recovery crews walk through the water or begin pumping operations.

Detection Methods. You can test for hydrogen sulfide with a hydrogen sulfide detector, a multi-gas detector, and by chemical analysis. Because H<sub>2</sub>S is relatively heavy, hold your portable detector low when testing for this gas. You may recognize H<sub>2</sub>S by its distinctive "rotten egg" odor. However, continued exposure to the gas will dull your sense of smell, so this may not always be a reliable detection method. Eye irritation is another indication that hydrogen sulfide is present.

When to Test: Test for hydrogen sulfide in poorly ventilated areas of the mine, during unsealing operations, and following mine fires.

Meaning of Findings. A buildup of hydrogen sulfide could indicate that ventilation is inadequate. It may also be produced by seepage from an oil or gas well. The presence of hydrogen sulfide might also indicate that excess water is accumulating in sealed or inaccessible areas of the mine.

## Sulfur Dioxide (SO<sub>2</sub>)

**NOTE TO TRAINER:** Distribute copies of the Visual 17 handout and refer to it as you discuss the properties and characteristics of sulfur dioxide. You may also use this visual as a PowerPoint or write the information on a chalkboard.

Specific Gravity. 2.2638

Explosive Range and Flammability. Will not burn or explode.

Health Hazards. Sulfur dioxide is a very toxic, irritating gas that is dangerous even in small concentrations; as little as 0.04 to 0.05 percent (400 to 500 ppm) is dangerous to life. Even very tiny amounts of sulfur dioxide (.001 percent or less – 10 ppm or less) will irritate your eyes and respiratory tract. Larger concentrations can cause severe lung damage and may cause respiratory paralysis and the complete inability to breathe.

Solubility. Highly soluble in water. (Sulfur dioxide is one of the most soluble gases found in mines.)

Color/Odor/Taste. Sulfur dioxide is colorless, but it has a bitter, acid taste and a strong sulfurous odor.

Cause or Origin. Sulfur dioxide may be produced by blasting in sulfide ores and by fires containing iron pyrite (commonly known as “fool’s gold”). Sulfur dioxide may be released during the burning of some diesel fuels and by sulfide ore dust explosions.

Where Found. Because it is relatively heavy, sulfur dioxide tends to collect in low places in the mine and near sumps. You can expect to find it after some fires or explosions.

Other Information. Because of its high specific gravity, sulfur dioxide is hard to disperse by ventilation.

Detection Methods. You may test for sulfur dioxide by means of a multi-gas detector or by chemical analysis. Because sulfur dioxide is a relatively heavy gas, hold portable detectors low when you test for it. Sulfur dioxide’s distinctive odor and taste, and the respiratory tract and eye irritation you’ll experience when exposed to it are also reliable indicators of its presence.

When to Test. Because it’s highly soluble in water, test for sulfur dioxide when stagnant water is disturbed. Test for this gas following fires or explosions, and when sealed areas of the mine are opened after mine fires.

Meaning of Findings. High SO<sub>2</sub> readings could indicate a mine fire or a sulfide ore dust explosion.

## Methane (CH<sub>4</sub>)

**NOTE TO TRAINER:** Distribute copies of the Visual 18 handout and refer to it as you discuss the properties and characteristics of methane. You may also wish to use this visual as a PowerPoint or write the information on a chalkboard.

**Note:** Methane does not occur in all metal/nonmetal mines; however, it does occur in some mines such as salt, oil shale, and trona mines. Use this lecture material only if methane is a possible gas in the mine or mines in which the team will be working.

Specific Gravity. 0.5545

Explosive Range and Flammability. Methane is flammable. Its explosive range is 5 to 15 percent when there is at least 12.1 percent oxygen. Methane is most explosive, however, in the 9.5 to 10 percent range. Methane's explosive range is not an absolute measure of safety. There are other important factors to consider. For example, the presence of other combustible gases with wider explosive ranges or lower ignition points than methane may result in a more highly explosive mixture.

Health Hazards. Methane is not toxic. In high concentrations, however, it can cause asphyxiation by lowering the oxygen content of normal air. The most dangerous aspect of methane is the fact that it is explosive.

Solubility. Slightly soluble in water.

Color/Odor/Taste. Colorless, odorless, and tasteless.

Cause or Origin. Methane may be liberated from the strata in metal/nonmetal mines when carbonaceous shale is penetrated, and occasionally when carbonaceous rock is contacted or is in the vicinity. Methane can issue in large quantities from sudden outbursts or from feeders or blowers or clay veins in some mines. Methane can also be liberated by the decomposition of timbers and when water is removed from the mine.

Where found. Because methane is relatively light, it collects in high places, so you can expect to find it near the back of the mine. You also may find it at freshly mined areas, in poorly ventilated areas, and in abandoned or unused sections of the mine, especially where timbering is extensive. Because it is a relatively light gas (low specific gravity), methane is usually easy to disperse and removed from the mine by means of ventilation.

Detection Methods. To test for methane, use a methane detector or chemical analysis. Remember that methane is a light gas, so hold your portable detector high.

Where to test. In mines where methane is possible, test as often as necessary during exploration to determine the methane content of the surrounding atmosphere. Also test for methane when normal ventilation is disrupted and when you are entering abandoned workings or removing water from old workings.

Meaning of Findings. If methane is present, it's important to monitor it carefully because it is potentially explosive if there is enough oxygen present. If methane exists in potentially explosive concentrations or in combination with other gases that extend its explosive range, your team may be required to leave the mine.

## **Heavy Hydrocarbons**

### **Ethane (C<sub>2</sub>H<sub>6</sub>), Propane (C<sub>3</sub>H<sub>8</sub>), and Butane (C<sub>4</sub>H<sub>10</sub>)**

#### Specific Gravity.

Ethane – 1.0493  
Propane – 1.5625  
Butane – 2.0100

#### Explosive Range and Flammability.

Ethane – from 3 to 12.5 percent in normal air.  
Propane – from 2.12 to 9.35 percent in normal air.  
Butane – from 1.86 to 8.41 in normal air.

Health Hazards. These gases are not toxic. At high concentrations they can displace enough oxygen to cause death by asphyxiation, but you'll rarely find them in such high concentrations in mines.

Solubility. All three are slightly soluble in water.

Color/Odor/Taste. All three are colorless and tasteless. In certain concentrations, propane and butane may produce a characteristic "gassy" odor. Ethane is odorless.

Cause or Origin. After mine fires, small concentrations of these gases are often detected along with methane in mines that have methane. They also sometimes leak from gas or oil wells.

Where Found. The heavy hydrocarbons are often found in mines adjacent to oil or gas wells. Because they are heavy, these gases collect in low areas of the mine.

Detection Methods. You can detect ethane, propane, and butane with a portable detector or by chemical analysis. Because these gases are relatively heavy, hold your portable detector low when you test for them.

When to Test. Test for these gases following fires or explosions when methane is present. You should also test for the heavy hydrocarbons if oil or gas casings are accidentally entered during mining operations.

Meaning of Findings. In significant concentrations, the heavy hydrocarbons can extend methane's explosive range if the mine has methane. Elevated readings could indicate there has been a methane explosion, if this is possible in the mine, or that there is seepage from an adjacent gas or oil well.

## Acetylene (C<sub>2</sub>H<sub>2</sub>)

**Note:** For some mines, acetylene will not be a potential problem. Therefore, teach this material only if necessary.

Specific Gravity. 0.9107

Explosive Range and Flammability. Acetylene is combustible but it will not support combustion. Its explosive range in normal air is 2.5 to 80 percent.

Health Hazards. Acetylene is slightly toxic. In high concentrations, it can cause asphyxiation by depleting the oxygen in the atmosphere.

Solubility. Very slightly soluble in water.

Color/Odor/Taste. Acetylene is colorless and tasteless. It has a slight garlic odor.

Cause or Origin. Acetylene is formed when methane is burned or heated in air having low oxygen content.

Where Found. Acetylene is found after methane explosions in air having a low oxygen content.

Detection Methods. Test for acetylene with a multi-gas detector or by chemical analysis. You may also recognize it by its characteristic garlic odor. Since acetylene's specific gravity is near that of normal air, hold portable detectors at chest level.

When to Test. Test for acetylene after a methane explosion in air that is oxygen deficient.

Meaning of Findings. The presence of acetylene could indicate that an explosion has taken place in an area with low oxygen content, such as in a sealed area.

## Radon (Rn)

**Note:** This lecture material on radon should be taught especially to teams working in uranium mines.

Specific Gravity. 7.526

Explosive Range and Flammability. Nonexplosive and nonflammable.

Health Hazards. Radon is not toxic. However, radon and radon daughters—a decay product of radon—are radioactive and emit radiation. Continued exposure to high levels of these gases has been linked to the incidence of lung cancer. Mines are required to keep exposure to radiation below 4 WLM (Working Level Months) per year. The exposure for any one month is limited to one WLM.

**Note:** The working level is a measure of the potential alpha particle energy of radon daughters in the mine atmosphere.

Solubility. Radon is highly soluble in water.

Color/Odor/Taste. Colorless, odorless, tasteless.

Cause or Origin. Radon is a gaseous decay product of the uranium series and is found in all uranium mines. It can also be liberated, but to a lesser extent, from almost any rock or soil. As radon is liberated into a mine atmosphere, it continues to decay and forms airborne particles the size of atoms called radon daughters.

Radon daughters are particularly dangerous. They adhere to respirable dust, and can be inhaled with the dust. Once inhaled, they become deposited in the lungs where they continue to decay, giving off radiation and damaging lung tissue. Radiation can also be absorbed by the skin. If the radiation hazard in an area is very high, breathing protection and protective clothing may be required.

Where Found. Radon is mostly found in uranium mines. Stagnant air carries heaviest concentrations. Also, pools of water will carry radon. Radiation levels can jump extremely fast when ventilation is disrupted.

Detection Methods. Survey meters are used to sample particulate matter in the air on a scheduled basis. Dosimeters can be used to monitor an individual's exposure. They can be worn by the miners.

When to Test. Regular tests are required in uranium mines. Tests should be made when ventilation is disrupted and when opening a sealed area.

Meaning of Findings. Excessive readings would indicate a disruption of ventilation.



## Smoke, Rock-Strata Gases, and the Damps

Smoke is a result of combustion. It consists of tiny particles of solid and liquid matter suspended in the air. The particles in smoke are usually soot or carbon, and tar-like substances such as hydrocarbons.

Although smoke may irritate your lungs when you inhale it, it is not normally considered to be an asphyxiant. However, smoke usually contains carbon monoxide and other toxic or asphyxiating gases produced by fires. This is why it is so dangerous to inhale smoke.

Also, if there is a sufficient amount of hydrocarbons in the smoke, the hydrocarbons can make the smoke explosive.

**NOTE TO TRAINER:** You may wish to mention that smoke from burning conveyor belts or cable insulation also contains toxic substances produced by the decomposition of Neoprene. These are very toxic when inhaled. For more information on these gases, refer to Module 5 *Fires, Firefighting, and Explosions*.

Besides the dangers involved in inhaling smoke and its potential for explosion, smoke is also hazardous in another important way: The presence of smoke limits your visibility.

**This single factor adds an extra element of difficulty to any rescue or recovery operation.**

### Rock-Strata Gases

Rock-strata gases occur in some metal mining districts in the United States, particularly in Colorado and Nevada. Commonly called rock gas, it is assumed to be largely nitrogen and carbon dioxide, and is released from the rock strata under the influence of atmospheric pressures.

Because rock gas is largely nitrogen and carbon dioxide, the effect of rock gas is to produce an oxygen-deficient atmosphere. This can cause a person to suffocate if breathing protection is not worn.

### The Damps

“Damps” are the names early miners gave to mixtures of gases. Many of these terms are still in use today. These names often describe what causes the mixtures or how they affect miners.

**Whitedamp.** Whitedamp is a mixture of carbon monoxide and air which results from a mine fire. It gets the name “whitedamp” from the fact that it is found in high concentrations in black powder smoke, which is white. The carbon monoxide in this mixture makes it toxic.

**Stinkdamp.** This is a mixture of hydrogen sulfide and air. Stinkdamp gets its name from the characteristic “rotten egg” odor of hydrogen sulfide. It is highly toxic and in certain concentrations it can be explosive.

**Afterdamp.** This is a mixture of carbon monoxide, carbon dioxide, methane, oxygen, nitrogen, and hydrogen. It is called “afterdamp” because it’s usually found after a mine fire or explosion. Afterdamp is toxic to breathe, and it may also be oxygen-deficient. Carbon monoxide is the most poisonous of the gases in afterdamp.

**Blackdamp.** Blackdamp gets its name from the fact that this mixture caused miners’ lights to go out. It is actually a mixture of carbon dioxide, nitrogen, and air. Blackdamp is produced by methane fires and explosions, so it also probably contains carbon monoxide. This mixture is oxygen-deficient so it makes breathing difficult, and can cause suffocation.

**Firedamp.** This is a mixture of methane and air that will burn or explode when ignited. The “fire” in firedamp comes from the fact that the mixture is flammable.

**Review Questions:** Ask the team members the following questions and allow time for them to answer. Discuss the correct answers with them so they fully understand the material covered in this section.

1. Name two ways in which oxygen deficiency can occur in a mine.
  - a. The presence of other gases may dilute the oxygen content of the mine air.
  - b. Fires and/or explosions can consume oxygen.
  - c. Disrupted ventilation may result in oxygen-deficiency.
2. What are the explosive gases that may occur in the mine or mines you may be called to work in?

**Note:** Explosive ranges are included here so you can discuss them if you wish. Discuss the explosive ranges of the gases that are a problem at the mine or mines your team will be serving.

- a. Carbon monoxide 12.5 to 74.2%
  - b. Hydrogen 4.0 to 74.2% even with as little as 5% oxygen present
  - c. Hydrogen sulfide 4.3 to 45.5%
  - d. Methane 5 to 15% in at least 12.1% oxygen
  - e. Ethane 3.0 to 12.5%
  - f. Propane 2.12 to 9.35%
  - g. Butane 1.86 to 8.41%
  - h. Acetylene 2.5 to 80%
3. Name the gases that can be detected by color, odor, or taste, and explain these identifying features.
    - a. Carbon dioxide—acid taste in high concentrations.
    - b. Nitrogen dioxide—reddish brown in higher concentrations, odor and taste of blasting powder fumes.
    - c. Hydrogen sulfide—rotten egg odor (however, continued exposure deadens your sense of smell), slight sweetish taste.
    - d. Sulfur dioxide—sulfur odor, acid taste.
    - e. Propane and butane—“gassy” odor in certain concentrations.
    - f. Acetylene—slight garlic odor.
  4. Of the gases we’ve talked about, which ones are toxic if you inhale them?

Carbon monoxide, oxides of nitrogen, hydrogen sulfide, sulfur dioxide, and acetylene. (These gases are highly toxic, with the exception of acetylene, which is only slightly toxic.)

5. What are the five major damp? Explain what each mixture contains and why it's dangerous.
- a. Whitedamp—carbon monoxide and air. Toxic.
  - b. Stinkdamp—hydrogen sulfide and air. Toxic, and may be explosive.
  - c. Afterdamp—carbon monoxide, carbon dioxide, methane, oxygen, nitrogen, and hydrogen. Toxic, explosive, and can be oxygen-deficient.
  - d. Blackdamp—carbon dioxide, nitrogen, and air. Oxygen-deficient. Can cause suffocation.
  - e. Firedamp—methane (5 to 15%) and air. Can explode.

**Note:** For practical exercises relating to mine gases, their detection, and the use of detectors, refer to Module 8 *Mine Rescue Activity Book*.

[This Page Intentionally Left Blank]

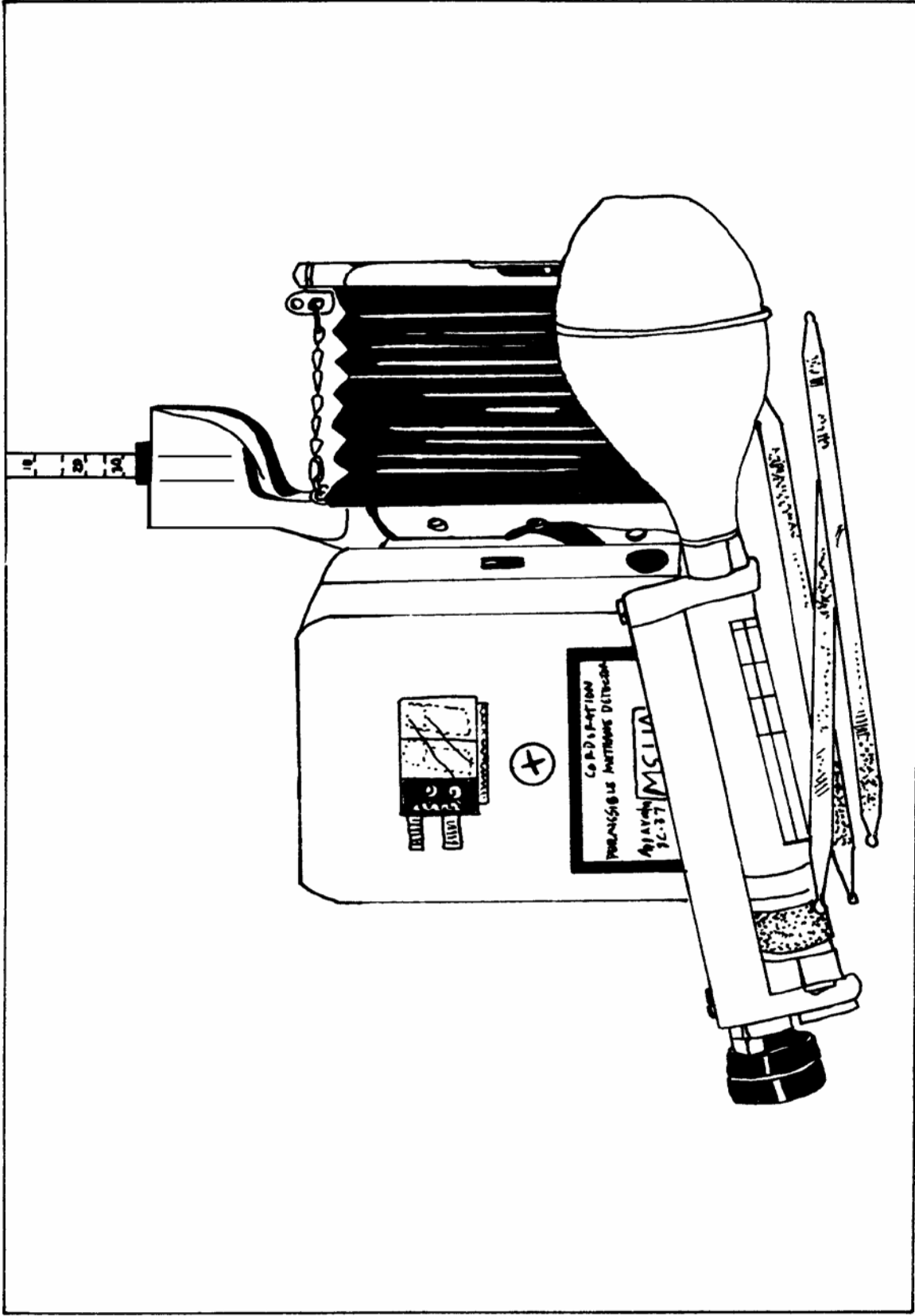

Visual 1

Gas Detectors

[This Page Intentionally Left Blank]

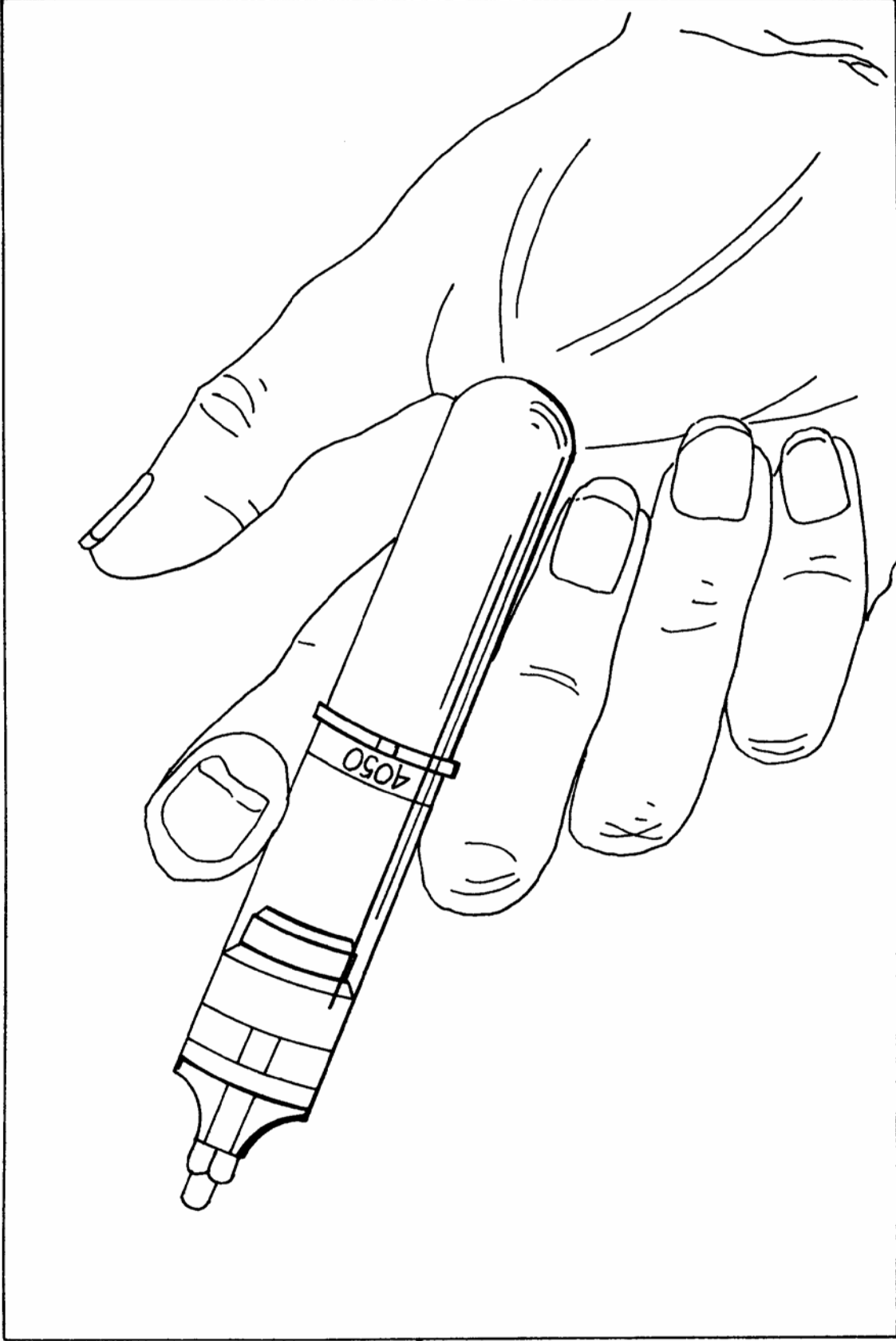

**Visual 2**

**Syringe for Gas Samples**



[This Page Intentionally Left Blank]

## **Effects of Temperature and Pressure**

Pressure increases – gas contracts

Pressure decreases – gas expands

Temperature increases – gas expands

Temperature decreases – gas contracts

**Visual 3**

**Effects of Temperature and Pressure on Gas**

[This Page Intentionally Left Blank]

**PRESSURE INCREASE**

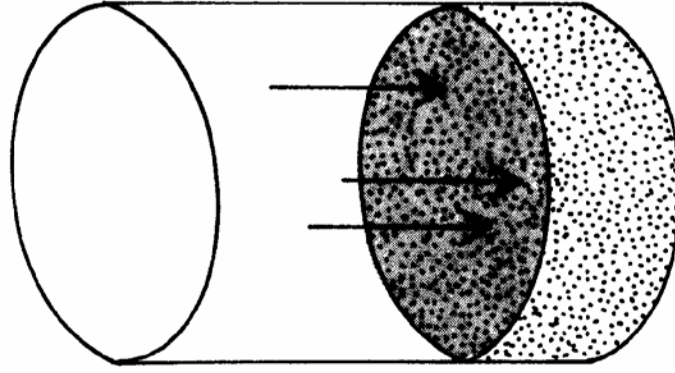

**DIFFUSES SLOWLY**

**PRESSURE DECREASE**

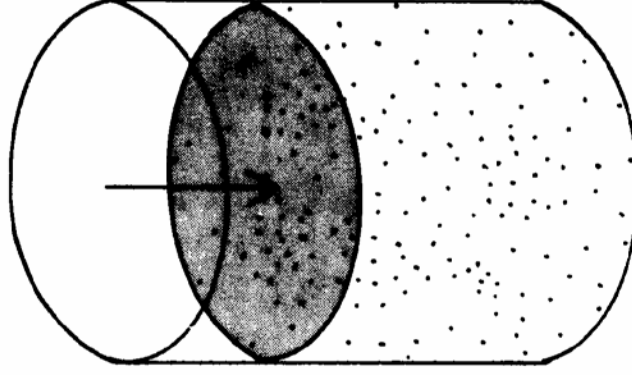

**DIFFUSES QUICKLY**

**Visual 4**

**Effects of Pressure on Gas**

[This Page Intentionally Left Blank]

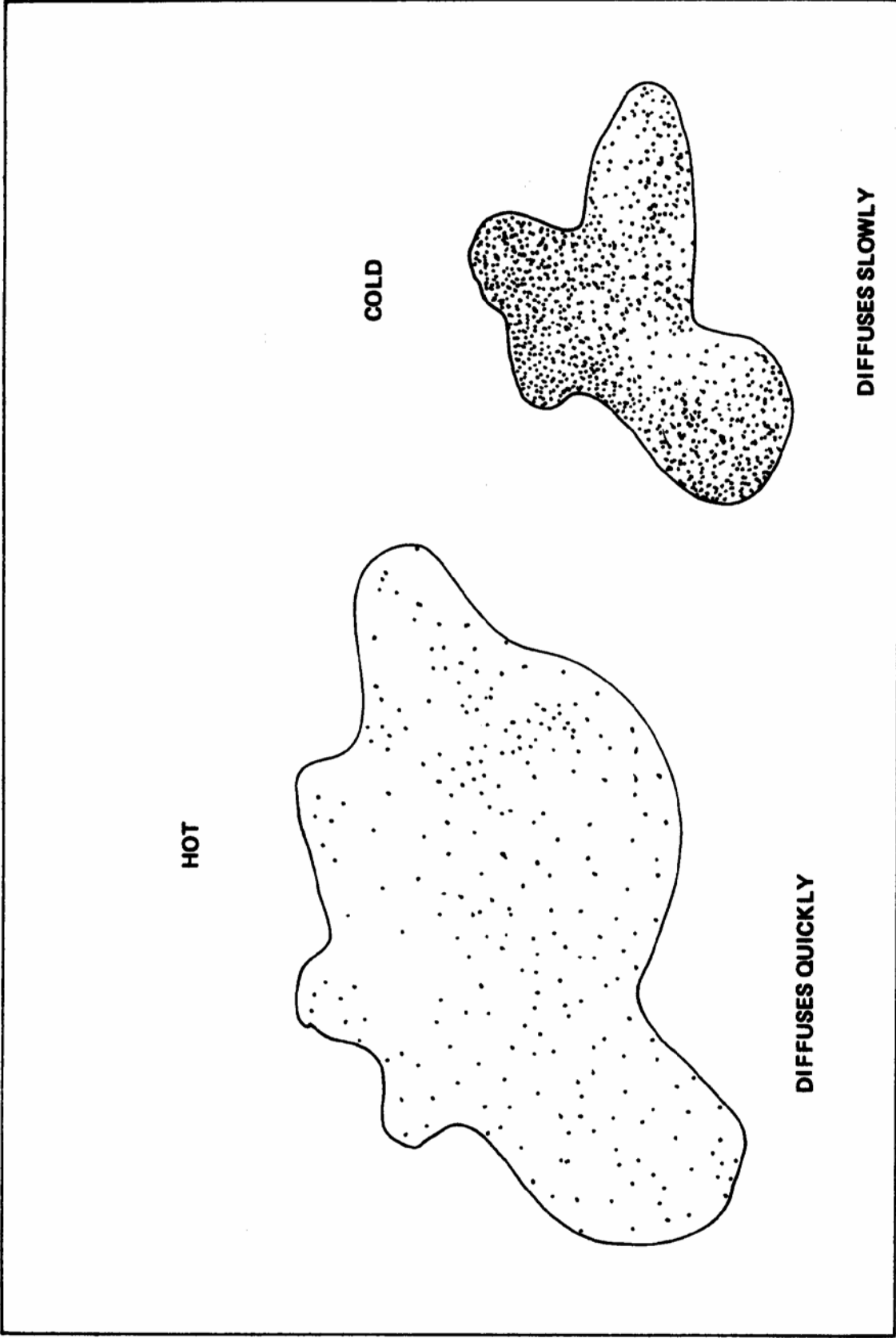

**Visual 5** Effects of Temperature on Gas

[This Page Intentionally Left Blank]

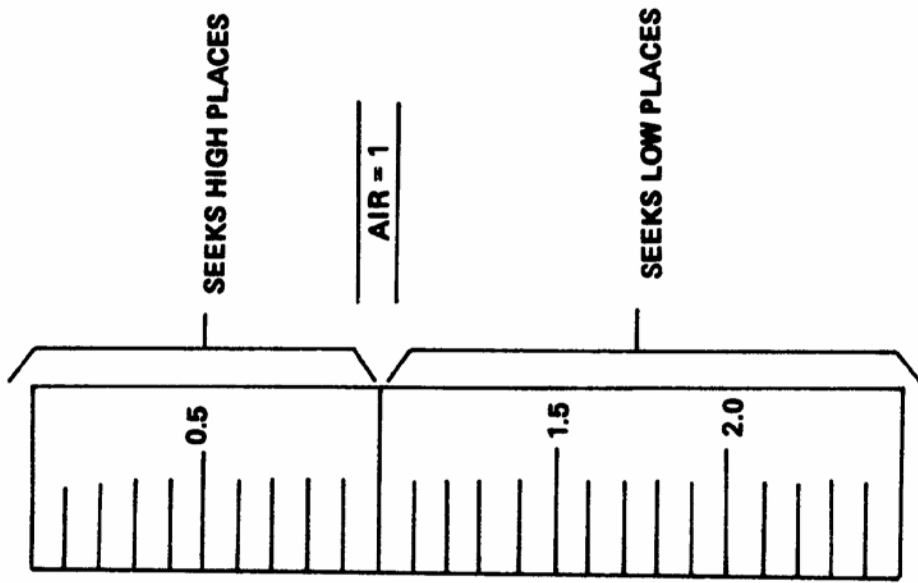

**Visual 6**

**Specific Gravity (Relative Weight)**



[This Page Intentionally Left Blank]

**EFFECTS OF TOXIC GAS DEPEND ON :**

**1. CONCENTRATION**

**2. TOXICITY**

**3. LENGTH OF EXPOSURE**

**Visual 7**

**Effects of Toxic Gas**

[This Page Intentionally Left Blank]

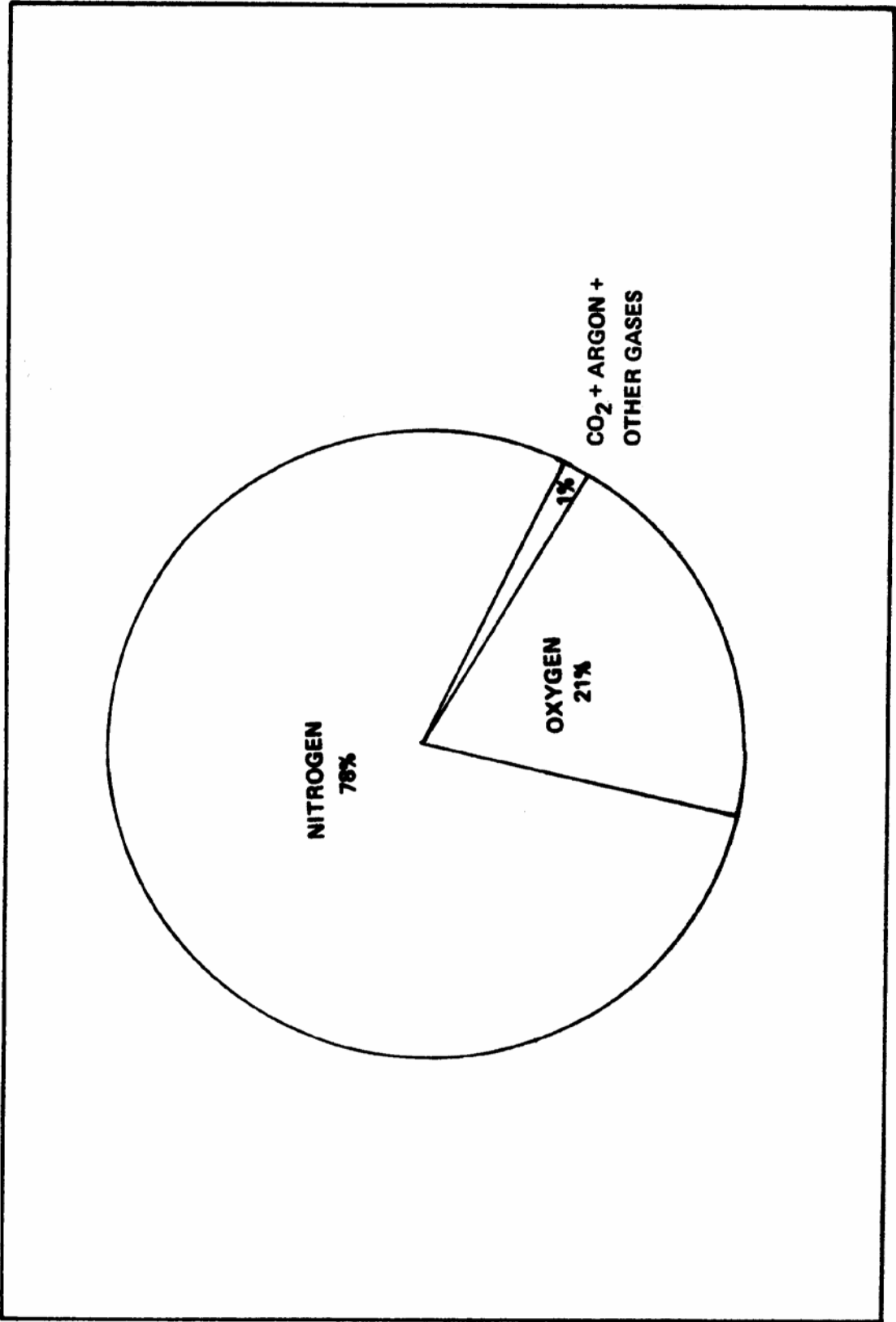

**Visual 8** Contents of Normal Air

[This Page Intentionally Left Blank]

Gas	Chemical Symbol	Specific Gravity	Explosive Range	Health Hazards	Solubility	Color	Odor	Taste
Air	--	1.000	--		--	--	--	--
Oxygen	O <sub>2</sub>	1.1054	Supports combustion	Oxygen deficiency: 17% panting, 15% dizziness and headache, 9% unconsciousness, 6% death.	Moderate	--	--	--
Nitrogen	N <sub>2</sub>	0.9674	--	Asphyxiant (oxygen depletion).	Slight	--	--	--
Carbon Dioxide	CO <sub>2</sub>	1.5291	--	Increases breathing rate. May cause death in high concentration.	Soluble	--	--	Acid in high concentrations
Carbon Monoxide	CO	0.9672	12.5 to 74.2%	Highly toxic. Can be an asphyxiant.	Slight	--	--	--
Nitrogen Dioxide	NO <sub>2</sub> N <sub>2</sub> O <sub>4</sub>	1.5894	--	Highly toxic. Corrosive effect on lungs. May be asphyxiant.	Only slight	Reddish brown	Blasting powder fumes	Blasting powder fumes
Hydrogen	H <sub>2</sub>	0.0695	4.0 to 74.2% Highly explosive	Asphyxiant (oxygen depletion).	--	--	--	--
Hydrogen Sulfide	H <sub>2</sub> S	1.1906	4.3 to 45.5%	Highly toxic. Can be an asphyxiant.	Soluble	--	Rotten eggs	Sweetish
Sulfur Dioxide	SO <sub>2</sub>	2.2638	--	Highly toxic. Can be an asphyxiant.	Highly	--	Sulfurous	Acid (bitter)
Methane	CH <sub>4</sub>	0.5545	5 to 15%	Asphyxiant (rare).	Slight	--	--	--
Ethane	C <sub>2</sub> H <sub>6</sub>	1.0493	3.0 to 12.5%	Asphyxiant (rare).	Slight	--	--	--
Propane	C <sub>3</sub> H <sub>8</sub>	1.5625	2.12 to 9.35%	Asphyxiant (rare).	Slight	--	"Gassy" in high concentrations	--
Butane	C <sub>4</sub> H <sub>10</sub>	2.0100	1.86 to 8.41%	Asphyxiant (rare).	Slight	--	"Gassy" in high concentrations	--
Acetylene	C <sub>2</sub> H <sub>2</sub>	0.9107	2.5 to 80%	Only slightly toxic. Asphyxiant (rare).	Only slight	--	--	Garlic
Radon	Rn	7.526	--	Exposure to radiation.	Highly	--	--	--

Visual 9

Mine Gas Chart (Handout)

[This Page Intentionally Left Blank]

Gas	Detection Methods	When to Test
Oxygen (O <sub>2</sub> )	Oxygen indicator. Chemical analysis.	During any team exploration.
Nitrogen (N <sub>2</sub> )	Chemical analysis.	When an oxygen deficient atmosphere is suspected. In mines where nitrogen issues from rock strata. In inactive areas where ventilation has been inadequate.
Carbon Dioxide (CO <sub>2</sub> )	Carbon dioxide detector. Multi-gas detector. Chemical analysis.	After a fire or explosion. When entering abandoned areas. When reopening sealed areas.
Carbon Monoxide (CO)	Carbon monoxide detector. Multi-gas detector. Chemical analysis.	During any team exploration, especially when fire is suspected.
Nitrogen Dioxide (NO <sub>2</sub> )	Nitrogen dioxide detector. Multi-gas detector. Chemical analysis. Color.	After mine fires or explosions. When diesel equipment is used. After detonation of explosives.
Hydrogen (H <sub>2</sub> )	Multi-gas detector. Chemical analysis.	After mine fire or explosion. Near battery-charging stations. When steam is produced by water, mist, or foam in fire-fighting.
Hydrogen Sulfide (H <sub>2</sub> S)	Hydrogen sulfide detector. Multi-gas detector. Chemical analysis. Eye irritation.	In poorly ventilated areas. During unsealing operations. Following mine fires.
Sulfur Dioxide (SO <sub>2</sub> )	Multi-gas detector. Chemical analysis. Odor, taste, and respiratory tract irritation.	When standing water is disturbed. After mine fires or explosions and when reopening sealed areas of the mine after mine fires.
Methane (CH <sub>4</sub> )	Methane detector. Chemical analysis.	During any team exploration. When normal ventilation is disrupted. When entering abandoned workings.
Heavy Hydrocarbons Ethane (C <sub>2</sub> H <sub>6</sub> ) Butane (C <sub>3</sub> H <sub>8</sub> ) Propane (C <sub>4</sub> H <sub>10</sub> )	Multi-gas detector. Chemical analysis.	Following fires or explosions when methane is present. Following accidental entry into adjacent oil or gas well casings.
Acetylene (C <sub>2</sub> H <sub>2</sub> )	Multi-gas detector. Chemical analysis. Odor.	Following a methane explosion in air which is low in oxygen.
Radon (Rn)	Survey meter.	When normal ventilation is disrupted and during unsealing operations.

## Visual 10

## Gas Detection Chart (Handout)



[This Page Intentionally Left Blank]

# Oxygen (O<sub>2</sub>)

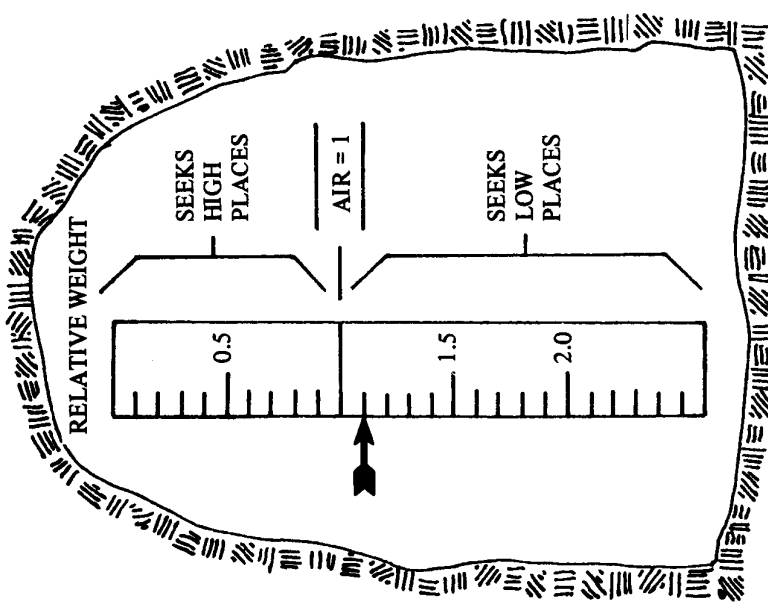
<p><b>SPECIFIC GRAVITY:</b> 0.1054</p> <p><b>EXPLOSIVE RANGE:</b> Supports combustion</p>	
<p><b>OTHER PROPERTIES</b></p> <p>Color: None</p> <p>Odor: None</p> <p>Taste: None</p>	
<p><b>CAUSE</b></p> <p>Air contains 21% oxygen. Oxygen is necessary for life. Oxygen deficiency is caused by humans breathing in confined spaces, insufficient ventilation, displacement by other gases, or consumption by fire or explosion.</p>	
<p><b>HEALTH HAZARDS</b></p> <p>Oxygen Deficiency: 17% -- panting          15% -- tightness in forehead, headaches, dizziness          9% -- unconsciousness          6% -- death</p>	
<p><b>DETECTION</b></p> <p>Use either oxygen indicator or chemical analysis.          Hold portable detectors at waist height. Test for oxygen deficiency as often as necessary during team exploration.</p>	

Visual 11

Oxygen Chart (Handout)

[This Page Intentionally Left Blank]

# Carbon Dioxide (CO<sub>2</sub>)

**SPECIFIC GRAVITY:** 1.5291

**EXPLOSIVE RANGE:** Not explosive

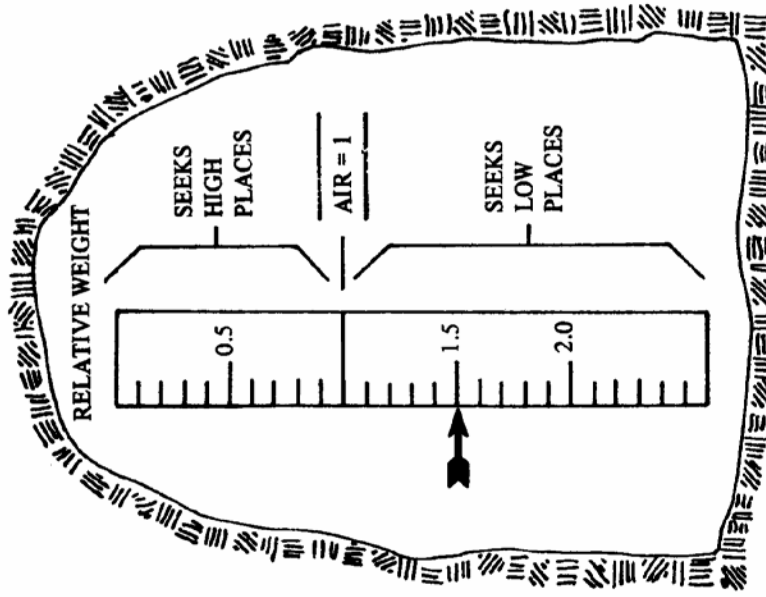

**OTHER PROPERTIES**

- Color:** None
- Odor:** None
- Taste:** High concentrations can produce an acid taste

**CAUSE**

CO<sub>2</sub> is normal component of air. Product of complete combustion. Is also produced:

1. By oxidation.
2. By decaying timbers.
3. As a by-product of breathing.
4. During fires, explosions, and blasting.

**HEALTH HAZARDS**

In high concentrations, CO<sub>2</sub> increases breathing rate. Can cause death.

**DETECTION**

Use carbon dioxide detector, multi-gas detector, or chemical analysis. Hold detector low. Test after a fire or explosion and when entering an inactive area of the mine or reopening a sealed area.

**Visual 12**

**Carbon Dioxide Chart (Handout)**

[This Page Intentionally Left Blank]

# Carbon Monoxide (CO)

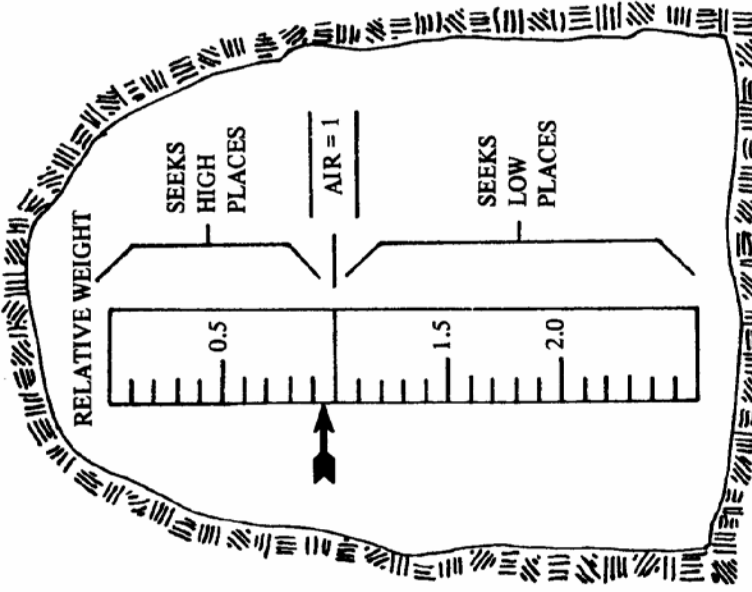
<p><b>OTHER PROPERTIES</b></p> <p>Color: None          Odor: None          Taste: None</p>	<p><b>SPECIFIC GRAVITY:</b> 0.9672</p> <p><b>EXPLOSIVE RANGE:</b> 12.5 to 74.2 percent in normal air</p>
<p><b>CAUSE</b></p> <p>Produced by incomplete combustion of carbon materials.          Produced by mine fires and explosions, burning or detonation of explosives, and internal combustion engines.</p>	
<p><b>HEALTH HAZARDS</b></p> <p>Extremely toxic even in low concentrations. Interferes with oxygen-carrying capacity of blood. First symptom: tightening across forehead. Effects cumulative over time. If exposed to high concentration, you experience few symptoms before losing consciousness.</p>	<p><b>DETECTION</b></p> <p>Can be detected by means of CO detector, multi-gas detector, chemical analysis. Hold detector at chest level. Test as often as necessary during team exploration, especially if fire is suspected.</p>

Visual 13

Carbon Monoxide Chart (Handout)

[This Page Intentionally Left Blank]

# Nitrogen Dioxide (NO<sub>2</sub>)

**SPECIFIC GRAVITY:** 1.5894

**EXPLOSIVE RANGE:** Not explosive

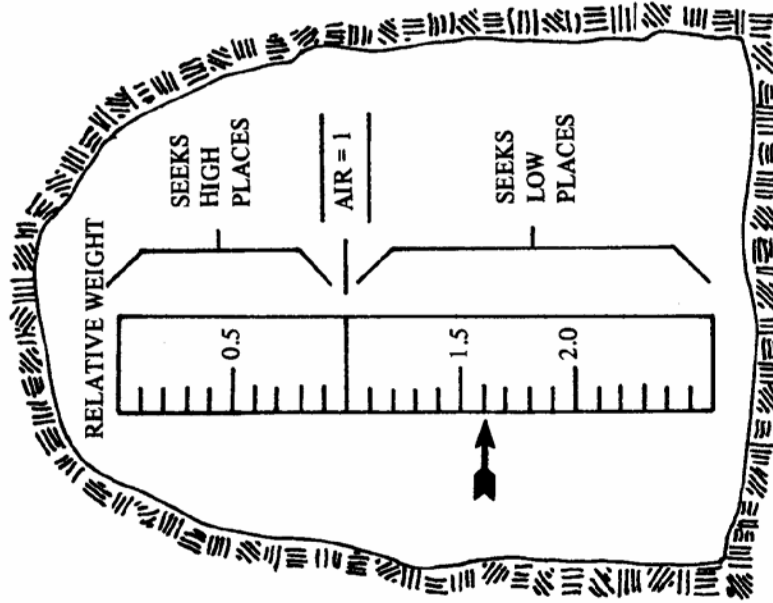

**OTHER PROPERTIES**

- Color:** Reddish brown
- Odor:** Blasting powder fumes
- Taste:** Blasting powder fumes

**CAUSE**

- Can be produced:
1. By burning.
  2. By detonation and burning of explosives.
  3. By diesel engines.
  4. In the presence of electrical arcs or sparks, nitrogen in the air combines with oxygen (oxidizes) to form oxides of nitrogen.

**HEALTH HAZARDS**

Very toxic, even small amounts will irritate throat. Mixes with moisture in lungs to form acids that corrode respiratory passages and cause them to swell. Exposure to .01 to .015% is dangerous. Exposure to .02 to .07% can be fatal.

**DETECTION**

Nitrogen dioxide detector, multi-gas detector, chemical analysis, color. Hold detectors low. Test following a fire or explosion and after the detonation of explosives. Test in areas where diesel equipment is found.

**Visual 14**

**Nitrogen Dioxide Chart (Handout)**



[This Page Intentionally Left Blank]

# Hydrogen (H<sub>2</sub>)

**SPECIFIC GRAVITY:** 0.0695

**EXPLOSIVE RANGE:** 4.0 to 74.2% in air with as little as 5% oxygen

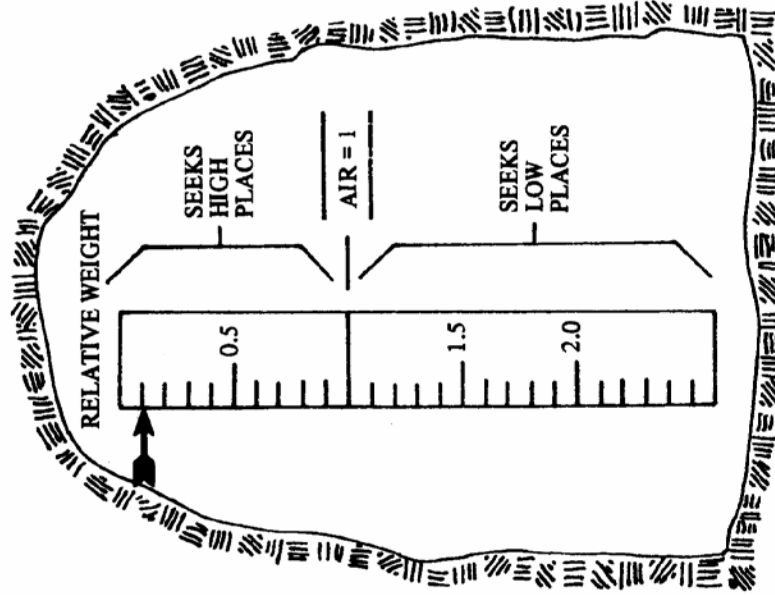

## OTHER PROPERTIES

**Color:** None

**Odor:** None

**Taste:** None

## CAUSE

Can be produced:

1. By incomplete combustion of carbon materials during fires and explosions.
2. When water or steam comes in contact with hot carbon materials during firefighting.
3. During battery charging.

## HEALTH HAZARDS

At high concentrations, hydrogen can replace oxygen in the air and act as an asphyxiant. Also, hydrogen is highly explosive.

## DETECTION

Use multi-gas detector or chemical analysis. Hold detector high. Test after any fire or explosion and near battery-charging stations. Also test when water, water mists, or foam are used to fight fires.

Visual 15

Hydrogen Chart (Handout)

[This Page Intentionally Left Blank]

# Hydrogen Sulfide (H<sub>2</sub>S)

SPECIFIC GRAVITY: 1.1906

EXPLOSIVE RANGE: 4.3 to 45.5% in normal air

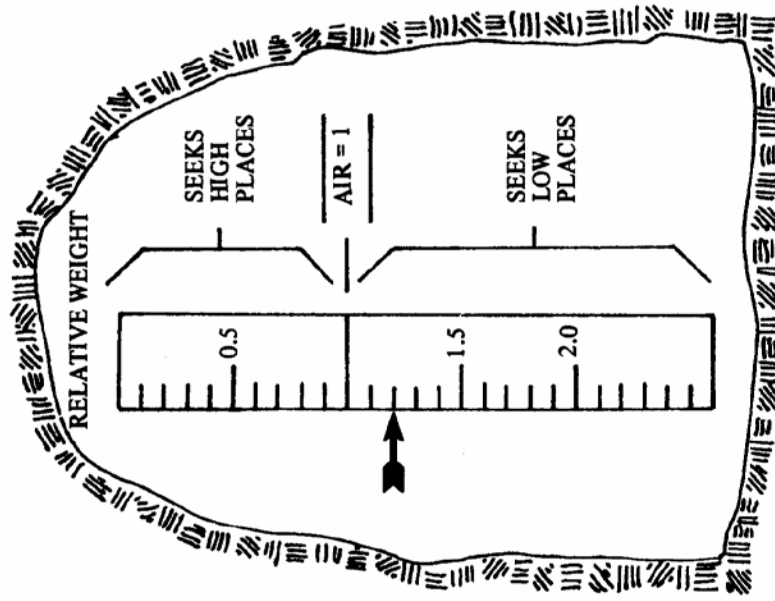

## OTHER PROPERTIES

Color: None

Odor: Rotten eggs

Taste: Slight sweetish taste

## CAUSE

Produced when sulfur compounds decompose. Found in certain oil and gas fields and in some gypsum mines. Can be liberated:

1. From methane feeders.
2. When acid mine water corrodes metallic sulfides.
3. From mine water that contains the gas in solution.
4. When sulfides are heated in the presence of moisture.
5. When sulfide ores are blasted.

## HEALTH HAZARDS

Extremely poisonous. .005 to .010% causes inflammation of eyes and respiratory tract. .02 to .07% can lead to bronchitis or pneumonia. .07 to .10% can cause rapid unconsciousness, cessation of respiration, and death. .10 to .20% or more can cause rapid death.

## DETECTION

Use hydrogen sulfide detector, multi-gas detector, or chemical analysis. Hold detector low. Test in poorly ventilated areas of mine during unsealing operations, and following mine fires.

Visual 16

Hydrogen Sulfide Chart (Handout)

[This Page Intentionally Left Blank]

# Sulfur Dioxide (SO<sub>2</sub>)

**SPECIFIC GRAVITY:** 2.2638  
**EXPLOSIVE RANGE:** Will not burn or explode

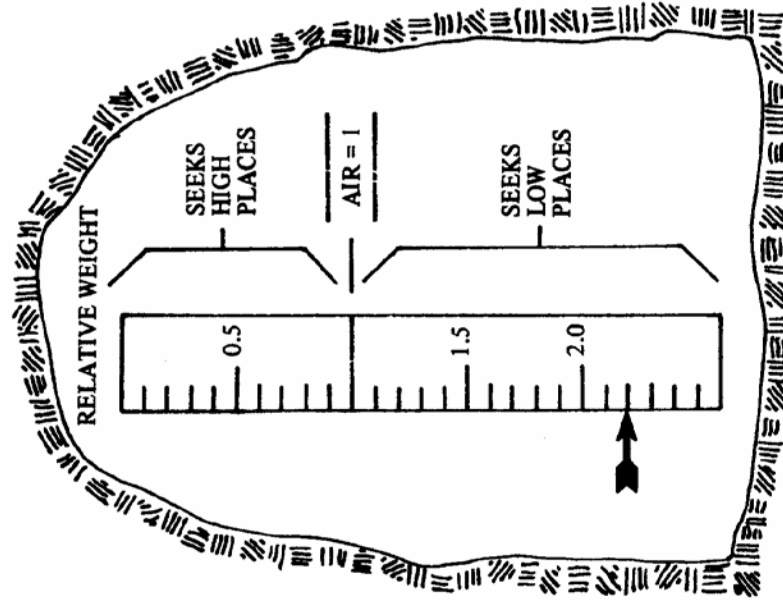

**OTHER PROPERTIES**

**Color:** None  
**Odor:** Sulfurous  
**Taste:** Bitter, acid

**CAUSE**

Can be produced:  
 1. By blasting in sulfide ores and by fires containing iron pyrite.  
 2. During the burning of some diesel fuels.  
 3. By sulfide ore dust explosions.

**HEALTH HAZARDS**

Very toxic, dangerous in even small concentrations.

**DETECTION**

Use multi-gas detector or chemical analysis. Test in low places and near sumps, following fires or explosions and during unsealing operations. Also, because it's highly soluble in water, test when stagnant water is disturbed.

**Visual 17**

**Sulfur Dioxide Chart (Handout)**

[This Page Intentionally Left Blank]

# Methane (CH<sub>4</sub>)

**SPECIFIC GRAVITY:** 0.5545

**EXPLOSIVE RANGE:** 5 to 15% in air containing at least 12.1% oxygen

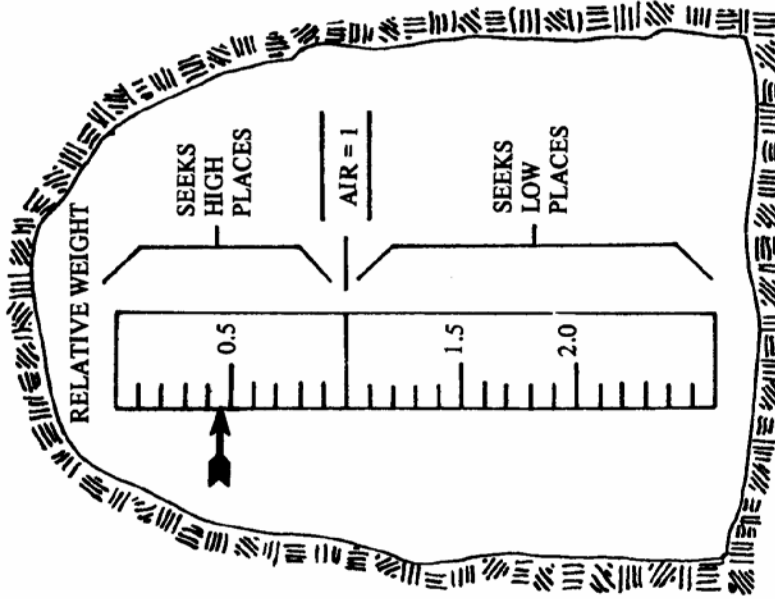

**OTHER PROPERTIES**

Color: None

Odor: None

Taste: None

**CAUSE**

Can be liberated:

1. From the strata when carbonaceous shale is penetrated.
2. Occasionally when carbonaceous rock is contacted or in vicinity.
3. From feeders or some clay veins.
4. By the decomposition of timbers.
5. When water is removed from mine.

**HEALTH HAZARDS**

Nontoxic. May cause asphyxiation at high concentrations.

Most dangerous aspect is the fact that it's explosive.

**DETECTION**

Use methane detector or chemical analysis. Hold portable detectors high. Test as often as necessary during team exploration. Test when normal ventilation is disrupted and when entering abandoned workings.

**Visual 18**

**Methane Chart (Handout)**

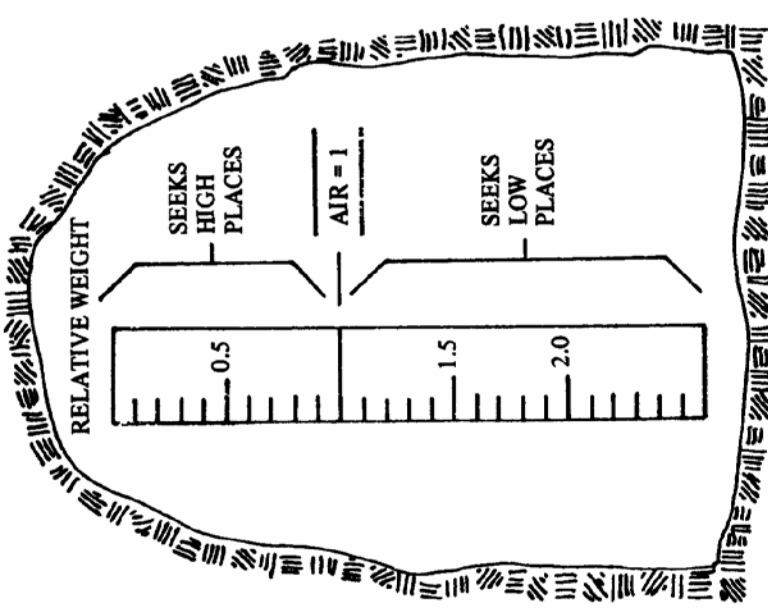

[This Page Intentionally Left Blank]

<p><b>OTHER PROPERTIES</b></p> <p>Color:</p> <p>Odor:</p> <p>Taste:</p>	<p><b>SPECIFIC GRAVITY:</b></p> <p><b>EXPLOSIVE RANGE:</b></p> 
<p><b>CAUSE</b></p>	<p><b>HEALTH HAZARDS</b></p>
<p><b>DETECTION</b></p>	

**Visual 19**

**Fill-in Gas Chart**

[This Page Intentionally Left Blank]

# General Review

## Mine Gases

Choose the correct answer to each of the following questions.

1. Normal air contains approximately what percent oxygen?
  - a. 15%
  - b. 21%
  - c. 31%
  - d. 79%
2. Carbon monoxide is:
  - a. gas found in all mining operations
  - b. a normal constituent of air
  - c. detected during a mine fire or explosion
  - d. a product of the breathing process
3. An elevated concentration of carbon dioxide in mine air can be harmful because:
  - a. it is highly explosive
  - b. it increases the breathing rate
  - c. it is highly toxic in small concentrations
  - d. all of the above
4. An elevated concentration of nitrogen in mine air can be harmful because:
  - a. it can lower the oxygen content of the air
  - b. it is highly explosive
  - c. it is highly toxic
  - d. all of the above
5. Oxides of nitrogen can occur in a mine atmosphere:
  - a. when certain explosives are used
  - b. when diesel-powered equipment is being used
  - c. when electric equipment produces arcs or sparks
  - d. all of the above
6. Accumulations of hydrogen in the mine atmosphere are dangerous because hydrogen:
  - a. is highly toxic
  - b. is highly soluble in water
  - c. is highly explosive
  - d. gives off a suffocating odor

7. Characteristics of hydrogen sulfide include:
  - a. explosive
  - b. highly toxic
  - c. can be liberated from pools of stagnant water
  - d. all of the above
  
8. Which of the following is not true of sulfur dioxide?
  - a. It is explosive
  - b. it is highly toxic
  - c. it is highly soluble in water
  - d. it can occur during mine fires
  
9. The most likely source of ethane, propane, or butane in a mine is:
  - a. use of diesel equipment
  - b. battery charging stations
  - c. leakage from adjacent gas or oil wells
  - d. all of the above
  
10. Acetylene would normally be found in a mine atmosphere where:
  - a. diesel equipment is used
  - b. methane has burned or exploded in air with a lowered oxygen content
  - c. leakage has occurred from adjacent oil or gas wells
  - d. battery charging stations are located
  
11. Match each damp with its components:
 

1. Firedamp	a. Carbon monoxide and air
2. Blackdamp	b. Hydrogen sulfide and air
3. Afterdamp	c. Carbon dioxide, nitrogen, and air
4. Whitedamp	d. Carbon monoxide, carbon dioxide, methane, oxygen, nitrogen, and hydrogen
5. Stinkdamp	e. Methane and air
  
12. Mine rescue teams are required by Federal law to have available:
  - a. one detecting device for each gas normally encountered in the mine(s) the team serves
  - b. one detecting device for each gas normally encountered in the mine(s) the team serves
  - c. four detecting devices for each gas normally encountered in the mine(s) the team serves
  - d. one detecting device for each team member

13. Atmospheric pressure and temperature are important factors because they:
  - a. affect the rate of diffusion of a gas by ventilation
  - b. can cause false readings on gas detection instruments
  - c. lower oxygen content in the mine
  - d. all of the above
  
14. Two gases that are highly soluble in water are:
  - a. methane and acetylene
  - b. hydrogen sulfide and hydrogen
  - c. nitrogen and sulfur dioxide
  - d. hydrogen sulfide and sulfur dioxide
  
15. A gas that is normally found near the back or in high places in the mine is said to have a low:
  - a. level of toxicity
  - b. level of explosivity
  - c. specific gravity
  - d. level of solubility
  
16. A nontoxic gas can still be dangerous because it can:
  - a. displace oxygen
  - b. burn
  - c. explode
  - d. all of the above
  
17. Gases that are neither toxic nor explosive:
  - a. are not found in mine atmospheres
  - b. are not dangerous
  - c. can be dangerous because they can displace oxygen
  - d. cannot be detected with today's detection instruments

General review answers:

- |      |       |          |       |
|------|-------|----------|-------|
| 1. b | 6. c  | 11. (1)e | 12. c |
| 2. c | 7. d  | (2)c     | 13. a |
| 3. b | 8. a  | (3)d     | 14. d |
| 4. a | 9. c  | (4)a     | 15. c |
| 5. d | 10. b | (5)b     | 16. d |
|      |       |          | 17. c |

## Glossary

**Asphyxiate** – To suffocate or choke.

**Atmospheric pressure** – Force exerted by air. Atmospheric pressure is measured on a barometer.

**Blower** – A gas feeder under high pressure which causes the gas to issue at considerable velocity.

**Casing** – Piping used to support sides of a borehole and to prevent entry of loose rock, gas, or liquid.

**Combustible** – Capable of burning; flammable.

**Contaminant** – Something which fouls or impurifies.

**Corrode** – To eat away gradually.

**Damps** – Descriptive names given by miners to identify mixtures of gases.

**Diffuse** – To scatter, spread out, or blend.

**Disperse** – To scatter or get rid of; to dispel.

**Explosive range** – The range of concentrations within which a gas will explode if ignited (expressed in percentages).

**Feeder** – Small cracks in rock strata through which methane or other gas escapes.

**Flammable** – Burnable.

**Ignite** – To set on fire.

**Inundation** – The state of being flooded.

**Methane outburst** – Sudden emission of methane.

**Mine atmosphere** – The air in an underground mine.

**Oxidize** – To cause to combine with oxygen.

**Poison** – Substance which destroys life or health.

**PPM** – Parts per million.



**Smoke** – Tiny particles of solid and liquid matter suspended in air.

**Solubility** – Ability to dissolve in water.

**Specific gravity** – The weight of a gas compared to an equal volume of air under the same temperature and pressure.

**Sulfur** – A nonmetallic element which exists either free or in combination with other elements. It often occurs as pyretic sulfur, commonly known as “fool’s gold.”

**TLV** (Threshold Limit Value) – Used to denote the average concentrations of gases to which workers can (under Federal regulations) be exposed over an 8-hour daily period.

**Toxic** – Poisonous.

**Vacuum bottle** – Container used to collect gas samples for chemical analysis.

**WL** (working level) – Measure of the potential alpha particle energy of radon daughters in a mine atmosphere.

**WLM** (working level month) – Special unit used to measure workers’ exposure to airborne radiation.

**A Guide to  
Mine Rescue Training –  
Metal and Nonmetal**

**Mine Ventilation**

**Module 3**

# Table of Contents

Course Objectives .....	3-1
Course Materials .....	3-1
Course Outline .....	3-2
Instructor Notes and Suggested Lecture .....	3-3
Visuals.....	3-25
General Review.....	3-49
Glossary .....	3-53

# Course Objectives

## Main Objective

The mine rescue team members will understand how air is coursed through a mine and be able to identify ventilation controls, take air measurements, and build or alter ventilation controls when ordered to do so by the officials in charge.

## Supportive Objectives

The team members will be able to:

- Explain the purpose and methods of mine ventilation.
- Read a level or section ventilation map, identify ventilation controls, and explain how they affect the movement of air.
- Identify the proper chain-of-command for altering ventilation.
- Use air measurement devices.
- Construct ventilation controls.

# Course Materials

Required:

- Handouts and visuals from the back of this module
- Pencil and paper for each team member
- Your own mine maps showing ventilation
- Mine Rescue Activity Book

Suggested:

- Anemometer
- Smoke tube (and stopwatch)
- Laptop computer
- PowerPoint program
- Chalkboard or flipchart

# Course Outline

- I. Introduction
- II. Understanding ventilation
  - A. Airflow
  - B. Natural ventilation
  - C. Mechanical ventilation
- III. Ventilation maps
  - A. Map symbols
- IV. Ventilation controls
  - A. Types of
    - 1. Bulkheads
      - a. Permanent
      - b. Temporary
    - 2. Check curtains or run-through checks
    - 3. Line brattice
    - 4. Auxiliary fans and tubing
    - 5. Overcasts and undercasts
    - 6. Mine doors
    - 7. Regulators
- V. Assessing ventilation
  - A. Reporting condition of existing ventilation
  - B. Measuring airflow
    - 1. Anemometer
    - 2. Smoke tube
- VI. Building ventilation controls
  - C. Temporary bulkheads
  - D. Permanent bulkheads
  - E. Air locks
  - F. Line brattice

# Instructor Notes and Suggested Lecture

## Introduction

As mine rescue team members, you should be familiar with mine ventilation, in particular the ventilation of the mine in which you will be working. You should know the basics about ventilation methods and ventilation controls, as well as the more practical side for you as a team—how to build those ventilation controls.

**Note:** Because of the large diversity of minerals and ores mined in metal and nonmetal mines, and the diversity of mining techniques used, terminology will vary somewhat from operation to operation. Consequently, the mining terminology used in this training module may or may not agree completely with the terms used in your area. It may be necessary, therefore, for you to adapt and change some of the terminology to suit the needs of your team. For example, in salt mines, the term “back” (used throughout this module) will have to be changed to “roof.” Also, metal/nonmetal operations vary from multi-level mines to single-level, room-and-pillar mines. There will be references in the lecture to each type of operation and sometimes separate visuals. Use the material that applies to your operation.

After a fire, explosion, or flood in a mine, rescue teams are usually needed to go into the mine to assess and reestablish ventilation.

During exploration of the mine, your team will be checking the condition of the mine’s ventilation system as you advance. You might find controls that have been destroyed or altered. Your initial responsibility will be to report these conditions to the command center. **Under no circumstances do you ever alter ventilation without orders to do so from the command center.**

From your team’s reports, the command center will have a good overview of the mine’s ventilation system and the degree to which it has been damaged, if at all. The command center can then issue directions to the team on how to reestablish ventilation in the mine.

Because the command center must make their decisions based on what you see, it is extremely important that you assess the ventilation accurately. Then, when it comes to fixing the ventilation, the command center will be counting on you to build controls where and how you are instructed.

## Understanding Ventilation

The mine fan(s) can create this pressure differential either by blowing air into the mine or exhausting air from the mine.

An exhaust fan pulls or sucks old air out of the exhaust airway. This pulling causes a pressure differential which, in turn, pulls fresh air into the mine's intake.

Blower fans are used mostly in mines having little overburden. Because these mines may have surface cracks, a blower fan is used so that any air that leaks through the cracks will leak away from the mine, not into the mine.

In many cases, one main fan is used to ventilate the entire mine.

In some large multi-level mines, booster fans installed on certain levels are used along with the main fan to maintain the correct ventilation throughout the mine. If rescue teams are working in a mine with several booster fans, they should be aware of this.

To help ensure your team's safety while working underground, the main fan(s) should be monitored or guarded by an authorized individual to make sure that it operates continuously. If the fan goes down while you're underground, and hazardous conditions ensue, you may be recalled from the mine.

Also, this monitor or guard will help ensure that no alterations in the operation of the fan(s) will be made without orders from the command center.

## Airflow

**NOTE TO TRAINER:** Use a mine map of your own to aid in explaining the material in this section. Point out the main intake and exhaust. Also, be sure to trace the basic flow of air through the mine.

The purpose of mine ventilation is to provide a volume of air sufficient to disperse and remove harmful gases, dust, smoke, and fumes, and to provide adequate oxygen. When a mine is ventilated, air from the surface enters the mine at the main intake or intakes and is directed or "coursed" through the mine by a system of ventilation controls. These controls force the air to move in certain directions and at certain velocities so that it reaches all levels or sections of the mine. All the return air from the levels or sections is then channeled to the main exhaust and eventually exits the mine.

If shafts are used as the two main airways, the intake airway is called the **downcast** shaft, and the exhaust airway is referred to as the **upcast** shaft. Sometimes one shaft can be split to provide both an intake and exhaust airway. To obtain the 'flow' of air through the mine there must be a difference in air pressure between the intake and exhaust airways.

The basic principle underlying mine ventilation is that air always moves from high pressure regions to low pressure regions. Therefore, in order to get the air to flow from the intake to the exhaust, the exhaust air must be at a lower pressure than the intake.

If this pressure difference exists naturally between the two airways, then the mine has **natural** ventilation. Natural ventilation is one of two methods of ventilating a mine. The other method is **mechanical** ventilation where fans are used to create the pressure differential.

## Natural Ventilation

In natural ventilation, air flows because of the natural difference in pressure inside and outside the mine. This natural pressure can only be supplied by an energy source. The only natural energy source that can create and sustain an adequate airflow is thermal energy due to temperature difference. The thermal energy is added to the air as the air passes through working places and mine openings.

In general, warm air displaces cold air in the mine due to the differences in elevation and in temperature of the workings. Generally, the greater these temperature differences, the larger the natural ventilation pressure created and the larger the resulting airflow.

Natural ventilation is rarely used in mines because the pressure differential is usually not great enough to create a sufficient and steady flow of air through the mine.

## Mechanical Ventilation

With mechanical ventilation, mine fans are used to create the pressure differential by changing the air pressure at specified points in the mine. And the greater the pressure difference the fan creates, the faster the flow of air.

## Ventilation Maps

As mine rescue team members, you should know how to read a mine map that shows ventilation. This is basic knowledge for any team member, especially the map person. The team's map person is responsible for marking down information on the map as the team explores and assesses ventilation.

At the team's briefing before going underground, you will be given an up-to-date ventilation map of the area to be explored. You should study this map and get familiar with where you are going and what you should expect to see underground. If other teams have already explored part of the mine, the map will show what has been found and done on previous explorations.



Also, you should get familiar with that particular map's symbols since maps can differ from one mine to the next. It's a good idea for the map person to fix a legend of each map symbol to the bottom of the map or mapboard, as well as the scale to which the map is drawn.

## Map Symbols

**isual:** Refer to Visual 1 as you discuss the following map symbols. If the symbols used by the team's mine vary from the symbols provided in the visual, correct the list as necessary. You may use this visual as a PowerPoint, chalkboard sketch, or handout. Also display either a mine level ventilation map for a multi-level mine or a section ventilation map for a single-level mine. As you talk about the different symbols discussed here, point them out on your map. Also, trace the intake and exhaust through the level or section on the map.



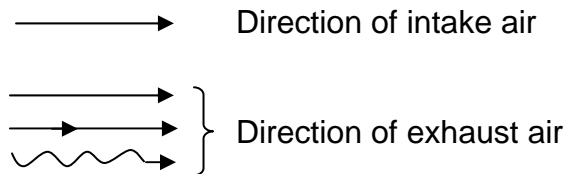





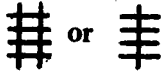

There are several ways to denote exhaust air. Three commonly used symbols are shown below.

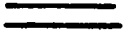
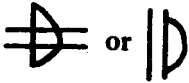
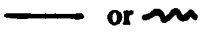
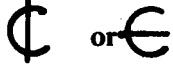

Sometimes, color-coded lines or arrows are used to indicate intake and exhaust airways (for example, red lines or arrows for intake air, and blue lines or arrows for exhaust air).

**NOTE TO TRAINER:** You may want to mention to the team that if the ventilation system is badly damaged or is out completely, the distinction between intake and exhaust air may not be valid. Also, teams should realize that during an emergency, the maps they receive may have been photocopied and, therefore, the colors of any color-coded lines will not show up

Some of the commonly used symbols on mine maps are shown below:

-  **Main fan**
-  **Track**
-  **Conveyor belt with loading and dumping points**
-  **Permanent bulkhead**
-  **Permanent bulkhead with mandoor**
-  **Temporary bulkhead**
-  **Check curtain or run-through check**
-  **Line brattice**
-  **Regulator**
-  **Auxiliary fan and tubing**
-  **Overcast (The open sides of the  indicate the flow of intake air.)**
-  **Undercast**
-  **Mine door (The curved line of the  indicates which way the door swings to open.)**

## Ventilation Controls

Ventilation controls are used underground to properly distribute the air to all sections of the mine. Ventilation controls do this by controlling both the direction of the airflow and the amount of air that travels. It is important to “control” and “course” air underground so that it reaches all areas of the mine.

The following ventilation controls that we are going to discuss work collectively to control the movement of air from the main intake(s), through the mine, and out the exhaust.

**NOTETO TRAINER:** While you talk about each of the following ventilation controls, point out the appropriate symbol on Visual 1 and on the mine map. Use this visual as a PowerPoint, chalkboard sketch, or handout.

### Bulkheads

Bulkheads are used to direct air to where it is needed and to keep intake air from short-circuiting to the exhaust before it reaches the working area.

**Note:** Bulkhead and stopping are two different terms for the same ventilation control. Bulkhead is used throughout this lecture. If your mine uses the term stopping, simply substitute that word for bulkhead when it appears in the lecture.

### Permanent Bulkheads

Permanent bulkheads are built of concrete blocks, sandfill, or other incombustible material. They are sealed tightly against the back, floor, and sides of a mine passage so that no air can leak through. Porous stoppings such as concrete block stoppings are usually plastered on the high-pressure side to reduce air leakage.

**NOTE TO TRAINER:** Refer to Visual 2 for a picture of a permanent bulkhead with a man door (drop door) in it as you talk about man doors next. Use this visual as a PowerPoint, chalkboard sketch, or handout.

Sometimes permanent bulkheads have a man door (or drop door) in them to allow miners to pass through. Man doors are not meant to be ventilation controls, but if a man door is propped open, it can affect airflow and may cause intake air to short circuit into the exhaust.

Also, some permanent bulkheads are built with a blast door in them. The blast door is designed to open and relieve pressure when there is blasting so that the bulkhead will not be blown out.

## Temporary Bulkheads

Temporary bulkheads are used to temporarily advance and direct the flow of air until a permanent bulkhead which is stronger and more airtight can be built.

Temporary bulkheads are usually built of canvas brattice cloth or plastic. Sometimes, however, they are built of wood or metal.

In mine rescue work, temporary bulkheads are used to advance ventilation as the exploration or mine recovery work progresses. There are specially designed temporary bulkheads for use in mine rescue work which are fast and easy to install. One of these is an inflatable, rubberized type. Another is a self-sealing type commonly referred to as a "parachute stopping."

Also, urethane foam, available in pressurized containers, is sometimes used by rescue teams for sealing the edges of a temporary bulkhead to make it more airtight.

## Check Curtains or Run-Through Checks

**Note:** Check curtains are used in some single-level, room-and-pillar mines. Omit this material if it is not relevant to the team.

**NOTE TO TRAINER:** Refer to Visual 3 for a picture of a check curtain or run-through check. Use this visual as a PowerPoint, chalkboard sketch, or handout.

A check curtain (or run-through check) is basically a brattice cloth, canvas, or plastic curtain that is hung across a passageway and opens to allow miners and equipment to pass through. Check curtains are used to deflect the intake air current into a working area. They are fastened at the top only and can be either one piece or have a slit in them or overlapping flaps.

Check curtains are designed to close automatically after you have passed through them so that they continue to direct air to the working place.

If check curtains get pulled down or they do not fully close, they can cause the air to short circuit so that it never reaches the working place. Nevertheless, if your team finds a fallen check curtain while exploring a mine, you should leave it as it is for the time being and report the condition to the officials at the command center. The command center will decide what changes to make in the ventilation, if any are necessary.

## Line Brattice

**NOTE TO TRAINER:** Refer to Visual 4 for an illustration of line brattice as used in multi-level mines or Visual 5 for a picture of line brattice as used in single-level, room-and-pillar mines. Use either visual as a PowerPoint, chalkboard sketch, or handout.

Line brattice is brattice cloth or plastic that is hung to channel intake air into a working area that otherwise would not have adequate ventilation.

In multi-level mines, line brattice can be used to direct intake air into a development drift. It is extended as the mining progresses to keep air flowing all the way to the end of the drift. For longer development drifts, sometimes the brattice is used with a fan, or the brattice is extended all the way across the main drift for increased airflow into the development drift.

In single-level mines that use the room-and-pillar method, line brattice can be used to channel intake air from the last open crosscut to the working section and across the face. Line brattice can be hung from a rough lumber frame, from timber posts, or from special fasteners. Line brattice is especially useful for rescue teams to use when they need to flush out or ventilate a small area of the mine.

## Auxiliary Fans and Tubing

**NOTE TO TRAINER:** Refer to Visual 6 to see how auxiliary fans and tubing can be used. Use this visual as a PowerPoint, chalkboard sketch, or handout.

In mines where drilling or blasting is done and large amounts of dust are produced, auxiliary ventilation systems are often used to control and direct airflow to or from the mining area. These auxiliary systems usually consist of a small, portable fan and tubing, sometimes referred to as a vent bag or a fanline. Sometimes, auxiliary fans are used without any tubing to direct air into a raise.

The auxiliary fan can be used to either exhaust or force the air. The tubing, which is usually suspended from timbers or eye bolts, carries the air to or away from the mining area. This tubing can be either rigid (for exhausting systems) or collapsible (for forcing systems).

## Overcasts and Undercasts

**Note:** Overcasts and undercasts are used in some single-level, room-and-pillar mines. Omit this material if it is not relevant to the team.

**NOTE TO TRAINER:** Refer to Visual 7 for a picture of overcast. Use this visual a PowerPoint, chalkboard sketch, or handout.

Because intake and exhaust air frequently cross paths at intersections within the mine, overcasts and undercasts are used to permit the two air currents to cross without the intake air short-circuiting into the exhaust.

Overcasts are like enclosed bridges built above the normal back level of the mine. Undercasts are like tunnels built below the normal floor of the mine. Undercasts are seldom used in a mine because they are apt to fill with water or debris which would severely slow down the flow of air through them.

Overcasts are used more often. They are usually built with concrete block walls sealed against the sides and floor, and with some type of airtight roof made of pre-stressed concrete, railroad ties, or steel beams.

## Mine Doors

**Note:** Some mines use the term air door instead of mine door.

In areas of heavy traffic, such as along haulageways, mine doors are used as ventilation controls. They are used to completely close off a mine passage yet open to allow equipment and people to pass through. Mine doors are generally used to keep air from flowing to areas where it is not needed. They can also be used to isolate separate splits of air.

Mine doors are usually hung in pairs, forming an air lock that prevents unnecessary air loss when one of the pairs of doors is opened. The doors should always be opened and closed one at a time in order to maintain the air lock.

Mine doors are always hung so that the ventilating air pressure will push them closed if they are accidentally left open. However, the doors should always be closed after you pass through them. Some doors must be closed manually while others can be closed automatically.

Some mines also use fire doors to control airflow in the event of a fire. They are usually built at shaft stations and other strategic locations so that if there is a fire they can be closed to serve as a barrier to the fire and contaminated air.

In some mines the fire doors will close automatically when the carbon monoxide in the air reaches a certain level. Some mines also have rollup doors in shop areas which close automatically when a mine fire warning is given.

## Regulators

**NOTE TO TRAINER:** Refer to Visual 8 to see how a regulator works. Use this visual as a PowerPoint, chalkboard sketch, or handout.

So far we have talked mainly about devices used to control the direction of airflow. Now we will discuss the regulators used to control and adjust the quantity of airflow in the mine in order to ensure proper distribution. A partially opened mine door can be used as a regulator.

There may also be a sliding door or window in a permanent bulkhead for adjusting the flow of air. If one of these regulator doors has been opened to allow miners to pass through, it must always be closed to the position in which it was found.

Or, a regulator can be made by knocking blocks out of a permanent bulkhead. The airflow can be adjusted by removing more blocks or replacing blocks.

**Review Questions:** Ask the team members the following questions and allow time for them to answer. Then discuss the correct answers with the team so they fully understand the material covered thus far.

1. Provide the symbol for each of the following ventilation terms: (If the symbols used at the team's mine differ from the ones provided here, be sure to use the team's symbols.)

a. Temporary bulkhead



b. Permanent bulkhead



c. Line brattice



d. Overcast (if used)



e. Undercast (if used)



f. Regulator



g. Mine door



h. Main fan



i. Auxiliary fan and tubing



j. Track

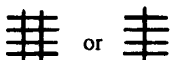



- k. Conveyor belt with belthead and tailpiece



- l. Man door (if used)

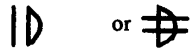

- m. Check curtain or run-through check (if used)

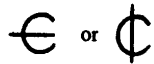

2. Have the team members discuss the purpose or function of the following:

- a. Bulkhead

Answer: Bulkheads are used to direct air through the mine. They keep intake air from short-circuiting to the exhaust before it reaches the working area.

- b. Line brattice

Answer: Line brattice is used to either (1) (for multi-level mines) direct intake air into a development drift that requires ventilation, or (2) (for single-level mines) channel intake air from the last open crosscut to the working section and across the face.

- c. Regulators

Answer: Regulators are devices used to control and adjust the quantity of airflow in the mine.

- d. Auxiliary fans and tubing

Answer: Auxiliary fans and tubing are used to provide sufficient airflow to working areas during mining operations.

## Assessing Ventilation

**NOTE TO TRAINER:** Refer to the *Activity Book* that accompanies these modules for an exercise in interpreting and working with a ventilation map.

As the team advances through the mine during exploration, all the ventilation controls should be checked, especially those in the affected part of the mine. When you come to a regulator or door, the position of it should be noted on the map by the mapman and it should be reported to the command center.

The officials at the command center need to receive accurate information from the team regarding the ventilation controls and air lines. They need to be kept well-informed about conditions underground so that they can make the appropriate decision as to what changes to make in the ventilation.

The command center should be told the **type** of damage you find and the **extent** of the damage. For example, if a bulkhead or other type of structure has been blown out by explosive forces, you should note the direction in which it appears to have blown. Even if bulkheads are not destroyed, indications of blocks having been moved should be reported.

Also, be sure to check the condition of the auxiliary fans and tubing, and the condition of the compressed air line. The positions of the valves (open or closed) on the air line should be reported to the command center and noted on the map.

The condition of the air lines is important for operating some equipment. For instance, some mines use air operated auxiliary fans. If the compressed air line is damaged, then the auxiliary ventilation would be cut off. Also, some high expansion foam generators are air powered.

More importantly, if there are trapped or missing miners in the mine, the air lines should be checked for another reason. Barricaded miners might use the line as an air supply.

**Mine rescue teams should never alter ventilation without direct orders from the command center.** The command center considers several factors before it orders a change in ventilation—most importantly, it has to consider how the alterations will affect ventilation into an unexplored area. The rule-of-thumb when altering ventilation is not to change the ventilation into an unexplored area.

**WARNING: The wrong alterations could cause changes in the air at the fresh air base, push deadly gases or smoke into areas where survivors are located, force explosive gases back over fire areas or hot spots and cause an explosion, or redirect and feed air to a fire.**

## Measuring Airflow

There are times when a team will be asked to determine the direction and velocity of airflow in a certain section of the mine. Knowing the velocity is important because the quantity of airflow can be calculated from it. Being able to determine the direction and velocity of airflow enables the team to check both whether the ventilation system is functioning as a whole and whether it is functioning as it should in a given area.

When a team takes the air direction and velocity measurements, it will report those findings to the command center. The officials at the command center will calculate the figures and compare them with the normal readings obtained previously at the mine.

The two instruments commonly used to measure air movement are the anemometer and the smoke tube.

The smoke tube is used mainly to determine what direction very slow-moving air is moving, and at what velocity. The anemometer is used to measure medium- and high-velocity air movement.

Sometimes the high velocities encountered are those flowing in ducts or tubing where measurements by anemometer are difficult. For such measurements the most practical instrument is the **pitot tube** which can be inserted through a small hole in the duct or tubing. The pitot tube has a U-tube water gauge or some other differential pressure gauge for determining the velocity pressure inside the duct or tubing.

## Anemometer

**NOTE TO TRAINER:** Refer to Visual 9 for a picture of a common type of anemometer. Refer to the Activity Book for a practice exercise using the anemometer.

An anemometer is a small sort of windmill with a mechanical counter for recording the number of revolutions caused by the moving air current. It is used to measure air velocities of over 120 feet per minute.

There are two types of anemometers:

1. A medium-velocity (or “regular”) anemometer for measuring velocities from 120 to 2,000 feet per minute; and
2. A high-velocity anemometer for measuring velocities from 2,000 to 10,000 feet per minute.

The anemometer actually measures **linear feet of travel** and requires timing—usually one minute—to determine **velocity** in feet per minute. Then the **area** of the airway (where the reading is taken) is computed in square feet. The **area** is then multiplied by the **velocity** to obtain the quantity of the air current in cubic feet per minute.

**NOTE TO TRAINER:** As you describe the following procedure, refer to Visual 10 for a drawing showing how to traverse the airway while taking an anemometer reading. Use this visual as a PowerPoint, chalkboard sketch, or handout.

**Demonstration:** As you describe the following procedure, you may wish to demonstrate how an anemometer reading should be taken.

A commonly used method of measuring the velocity in an airway is to traverse the airway so that you get an accurate measurement of the average velocity in the airway. The procedure for doing this is as follows:

1. Stand with your back to one side and hold the anemometer in a vertical position out in front of you at full arm's length. The anemometer should be positioned so that the air current will enter the back of it (that is, the side without the dials). Your free arm should be kept close to your body.
2. Turn the anemometer on and walk slowly to the opposite side, pacing yourself to get a one minute reading. Be sure to keep the anemometer out in front of you (to decrease resistance as much as possible).

The anemometer should be raised and lowered as you walk to the opposite side so that the average velocity of the air is measured.

3. At the end of one minute, turn off the anemometer and read the dials. This reading will have to be corrected by using the manufacturer's table of corrections for the various velocity readings.

**Note:** Refer to the manufacturer's instructions for the correct information on how to operate and read the anemometer.

4. Determine the cross-sectional area of the airway by multiplying the width times the height.
5. Report the velocity and area measurements to the command center. The command center will calculate the quantity of airflow in cubic feet per minute by multiplying the area ( $\text{ft.}^2$ ) by the corrected velocity ( $\text{ft./min.}$ ).

**Note:** If the anemometer reading is taken for less than a minute, the velocity reading will have to be converted to feet per minute.

## Smoke Tube

**NOTE TO TRAINER:** Refer to Visual 11 for a picture of a smoke tube. Use this visual as a PowerPoint, chalkboard sketch, or handout.

**Demonstration:** If you have a smoke tube, you may wish to demonstrate how to use it as you describe the procedure in the following section.

The smoke tube is used to show the direction and velocity of slow-moving air (below 120 feet per minute). The smoke tube is a device that emits a smoke cloud which floats along with the air current to show the direction of the airflow and the approximate velocity of the airflow.

The smoke tube consists of an aspirator bulb and a glass tube containing a smoke-generating reagent. To operate it, break off both ends of the glass tube and then squeeze the aspirator bulb to force air into the tube. A white cloud of smoke will come out of the tube and travel with the air current in the passage. This will show you the direction in which the air is flowing (in cases where the direction cannot otherwise be determined).

If you are not wearing breathing protection when working with the smoke tube, you should be careful not to come in contact with the smoke. It is extremely irritating and can cause choking.

There are two methods of measuring the velocity with a smoke tube. With one method, the reading is taken only at the center of the airway. This method is not very accurate as it gives only an approximate reading and a high reading because the center of an airway has the fastest moving air.

The more accurate method of determining the air velocity is to take readings at quarter points within the airway.

**NOTE TO TRAINER:** As you explain the following procedure, refer to Visual 12 showing how to take smoke tube readings at quarter points within the airway. Use this visual as a PowerPoint, chalkboard sketch, or handout.

You may wish to inform the team that quarter points are points at approximately the center of each quadrant if the airway were divided into four approximately equal parts. This is done to determine the average velocity in the airway since it varies at different parts of the airway.

1. Measure off a distance in a relatively straight and uniform airway. Twenty-five feet is usually a suitable distance for this measurement. (This distance should be determined by how well the smoke cloud holds together and how well it can be seen.)

2. Station one person with the smoke tube at the upwind point of the measured distance, and station one person with a stopwatch at the downwind point.
3. The person with the smoke tube then releases a smoke cloud at each quarter point within the airway. The person with the stopwatch then must time each cloud from the moment it is released until it reaches the downwind point. The measurements are taken separately, that is, the first smoke cloud is timed, then the second, and so forth.

Each velocity measurement in a quadrant should be repeated several times to determine an accurate average. Abnormal high and low measurements should be discarded, and the remainder averaged. A correction will then have to be made to the averaged figure because the air travel at the quarter points will average about 10 percent high.

**Note:** To make this correction, either multiply the averaged figure by 0.10 and subtract this number from the averaged figure, or multiply the averaged figure by 0.9.

4. Determine the average area of the airway along the measured distance by multiplying the width times the height.
5. Report the velocity and area measurements to the command center. The command center can then calculate the quantity of airflow in cubic feet per minute. The formula for this is:

$$\text{Quantity (ft.}^3\text{)} = \text{Area (ft.}^2\text{)} \times \text{Velocity (ft./min.)}$$

Velocity is always measured in feet per minute (for mine application).

**Exercise:** To do the next calculation you first have to convert the smoke tube reading into feet per minute. Let's say that 25 feet is the measured distance and it averages 23 seconds for the smoke cloud to reach the downwind point. You need to find the decimal equivalent of 23 seconds to find what fraction of a minute it is.

$$\frac{23 \text{ seconds}}{60 \text{ seconds}} = .38 \text{ minute}$$

So you would have:

$$\frac{25 \text{ feet of travel}}{.38 \text{ minute}} \quad \text{This equals } 65.7 \text{ ft./min.}$$

Now plug 65.7 into the formula:

$$Q \text{ (ft.}^3\text{)} = A \text{ (ft.}^2\text{)} \times V \text{ (ft./min.)}$$

$$\text{Quantity} = \text{Area (let's use 200)} \times 65.7$$

$$\text{Quantity of airflow} = 13,140 \text{ ft.}^3\text{/min}$$

If you intend to use the smoke tube over again in a short time, you should keep it tightly stoppered with a rubber cap or plug because the reagent is corrosive and tends to clog the openings of the tube.

**Review questions:** Ask the team members the following questions and allow time for them to answer. Then discuss the correct answers with the team so they full understand the material covered in the previous section.

1. Discuss reasons why mine rescue teams should not alter ventilation without authorization from the command center.

**Answer:**

- a. Altering the ventilation could force deadly gases into areas where survivors might be located.
  - b. It could force explosive gases over fire areas or hot spots and cause an explosion.
  - c. It could supply additional oxygen to a fire area and “feed” the fire.
  - d. It could also result in ventilation changes that would alter the air at the fresh air base.
2. Discuss the conditions under which a smoke tube would be used to determine air velocities.

**Answer:** The smoke tube is used to determine the direction and velocity of slow-moving air, below 120 feet per minute.

3. Discuss the conditions under which an anemometer would be used to determine air velocities.

**Answer:** The medium-velocity (or “regular”) anemometer is used to determine air velocities from 120 to 2,000 feet per minute. A high-velocity anemometer is used to determine air velocities from 2,000 to 10,000 feet per minute.

## Building Ventilation Controls

As we discussed before, mine rescue and recovery work often involves building or rebuilding ventilation controls in the mine in order to reestablish ventilation. Therefore, it is necessary that you know how to properly build ventilation controls, whether it be building a bulkhead or hanging line brattice.

Some of you will be skilled in building ventilation controls, while others may have little or no experience. But for all of you, whether or not you’ve done this type of work before, it’s going to take time to get used to working with your apparatus on. It will be especially hard if you are working in smoke or trying to work rapidly in order to reach survivors as quickly as possible. **Remember** – you are to make no alterations or do any construction without the approval of the Command Center.



## Temporary Bulkheads

When installing a temporary bulkhead in a passageway, particularly in a crosscut of a room-and-pillar, single-level mine, the bulkhead should be erected a sufficient distance into the passageway (at least 4 to 6 feet) to permit enough room for a permanent bulkhead to be built later.

The site for the temporary bulkhead should ideally have good ground conditions and little or no debris on the floor in order to obtain a good seal around the bulkhead. Good preparation of the area is essential in order to get a good seal. If necessary, scale any loose material from the back.

A post should be set at each side and, depending on the width of the passageway, more posts can be set between the sides. Boards should be nailed to the top and bottom of the posts to which the brattice or plastic can be attached. Or loose material can be shoveled onto the bottom surplus of brattice or plastic to seal the bottom of the bulkhead.

**Note:** Non-sparking tools and nails must be used in mines with explosive atmospheres to reduce the chance of a spark that could cause an ignition. Also, non-sparking shovels should be used to fill in around temporary bulkheads in such atmospheres.

If they are available, “pogo sticks,” which are spring-loaded expandable metal rods, can be used instead of posts to erect temporary bulkheads. These permit bulkheads to be built much faster, since posts do not need to be cut and fitted. They could also be used along with posts in wide passageways to reduce the number of posts that would normally be needed. **NOTE:** Pogo sticks are used only in certain areas of the country. If they are not used in your area, omit the lecture material on them.

If the mine has had an explosion, the team may encounter a great deal of debris, damage to bulkheads, and hazardous ground conditions. In order to restore ventilation under these conditions, teams might find it necessary to improvise and “control” the ventilation as much as possible.

Destroyed or damaged bulkheads in passageways that are filled with debris or have large pieces of equipment or ore cars in them can be sealed so that ventilation can be moved ahead.

In these cases, the team can hang brattice or plastic from the back and cut the brattice to fit around the piece of equipment or obstruction. Loose material can then be shoveled onto the excess brattice at the bottom and onto the equipment to effect as tight a seal as possible.

When miners are trapped and the rescue team is advancing fresh air to them, the work must be done as quickly as possible. Through teamwork, practice, and with the proper materials, a mine rescue team can erect adequate temporary bulkheads quickly and efficiently.

## Permanent Bulkheads

As soon as possible after ventilation has been restored to the mine, permanent bulkheads should be built to replace any temporary bulkheads. Under normal circumstances these permanent bulkheads would be constructed in good air, so they could be built by barefaced work crews rather than mine rescue teams.

There are instances, however, such as in sealing a fire area, where the mine rescue team, under oxygen, would be required to build a permanent bulkhead.

**Note:** Building seals to seal a fire area will be covered in the *Fires, Firefighting, and Explosions* training module.

## Air Locks

An air lock consists of two doors or two bulkheads with flaps or doors in them which are in close proximity to each other in the same passageway. The purpose of an air lock is to separate two different atmospheres while still permitting miners to enter and exit without mixing the atmospheres. In order to maintain the air lock, one door of the air lock must be kept closed while the other door is open.

In many mines during a rescue and recovery operation, air locks are put up to establish a fresh air base and enable teams to move forward into questionable air without contaminating the air at the fresh air base.

Air locks are also used any time a team is required to break open a bulkhead or open a door when the conditions on the other side of that bulkhead or door are not definitely known.

Air locks are also required prior to opening a refuge chamber, barricade, or door in irrespirable atmospheres behind which survivors may be located.

**Note:** Air locking will be covered in more detail in the *Mine Recovery* training module. Opening barricades will be covered in more detail in the *Rescue of Survivors and Recovery of Bodies* training module.

When erecting an air lock, the team should build the two bulkheads as close together as possible, yet with enough space to allow room for the team and their equipment to fit between.

## Line Brattice

Mine rescue teams may, at times, find it necessary to use line brattice to flush noxious or explosive gases from a mining area. The line brattice can be installed by erecting posts or supports with boards along the back to which the brattice can be attached. Or the brattice can simply be held up with pogo sticks, if available.

If the brattice needs to hang only for a short time, the team can simply hold up the brattice, extending it into the area to be ventilated. In these situations, each team member should hold up a section of the line brattice and try to get it as close to the back as possible.

**Review questions:** Ask the team members the following questions and allow time for them to answer. Then discuss the correct answers with the team so that they fully understand the material covered in the previous section.











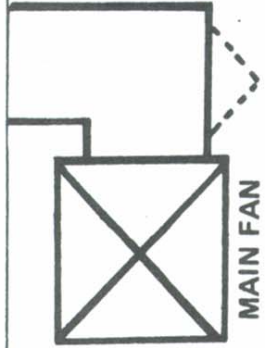

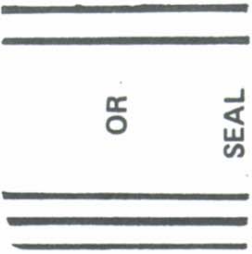
1. Have the team members discuss why they would build an air lock.

Answer: Air locks are necessary when opening a door or when breaking through a bulkhead when conditions on the other side are not known. Air locks are required when opening a refuge chamber or barricade in irrespirable atmospheres. In single level mines, air locks are used to establish a fresh air base and when advancing the fresh air base.

2. Have the team members discuss how they would build a temporary bulkhead in a passageway that has equipment in it.

Answer: The team should cut the brattice to fit around and over the equipment and secure the seal with loose material from the floor that can be shoveled onto the excess brattice along the floor and on the equipment.

**Note:** Refer to the *Activity Book* for a team exercise related to building ventilation controls.

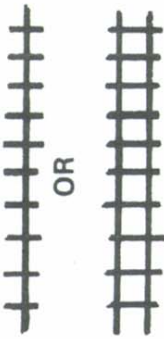
 <p>MAIN FAN</p>			
 <p>PERMANENT BULKHEAD</p>	 <p>TEMPORARY BULKHEAD</p>	 <p>OR</p>  <p>OR</p>  <p>MAN DOOR</p>	 <p>REGULATOR</p>
 <p>AUXILIARY FAN AND TUBING</p>	 <p>MINE DOOR</p>	 <p>LINE BRATTICE</p>	 <p>CONVEYOR BELT WITH LOAD AND DUMP POINTS</p>
 <p>UNDERCAST</p>	 <p>OVERCAST</p>	 <p>OR</p> <p>TRACK</p>	

Sample Mine Map Symbols

Visual 1

[This Page Intentionally Left Blank]

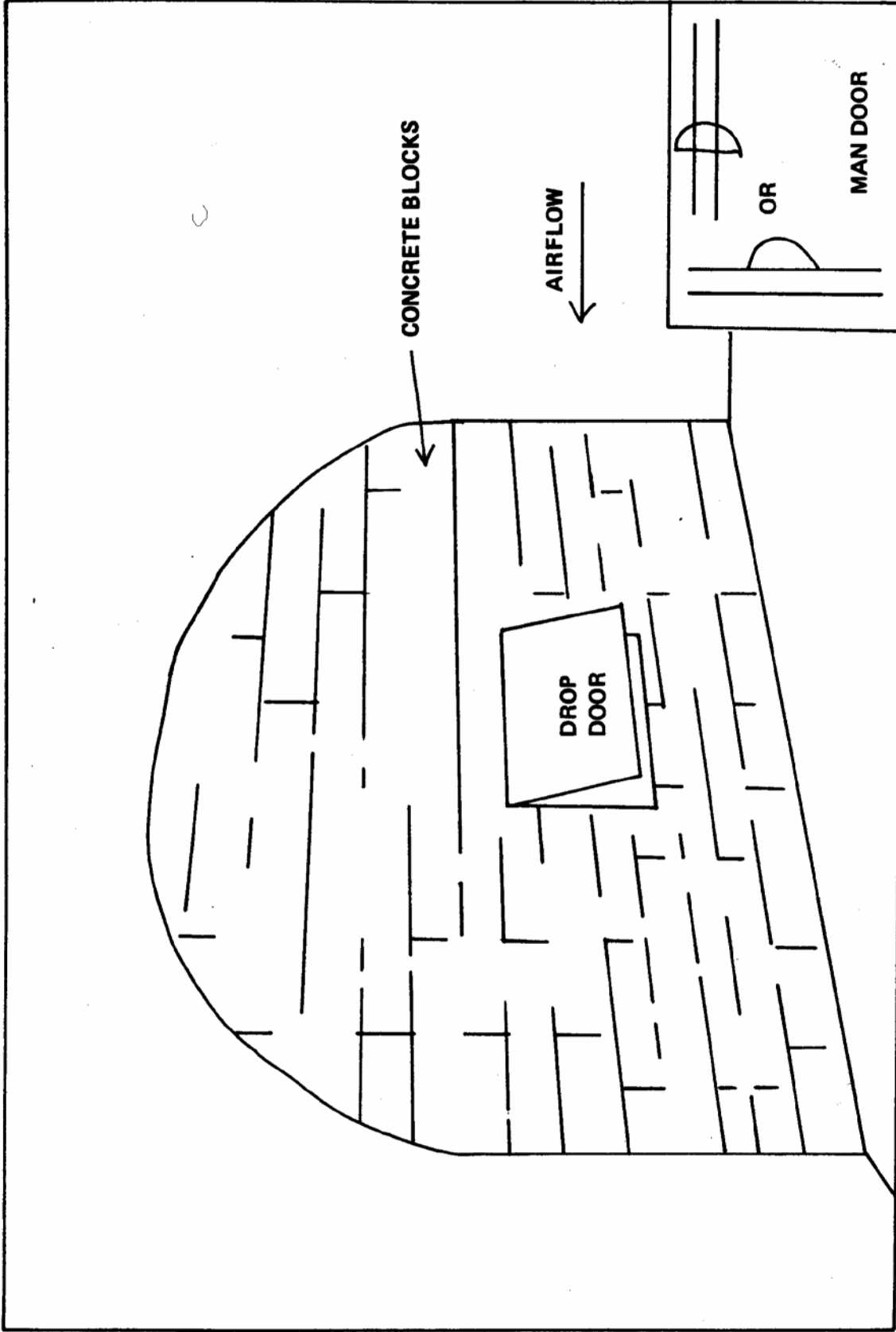

**Visual 2 Permanent Bulkhead With Man Door (or Drop Door)**

[This Page Intentionally Left Blank]

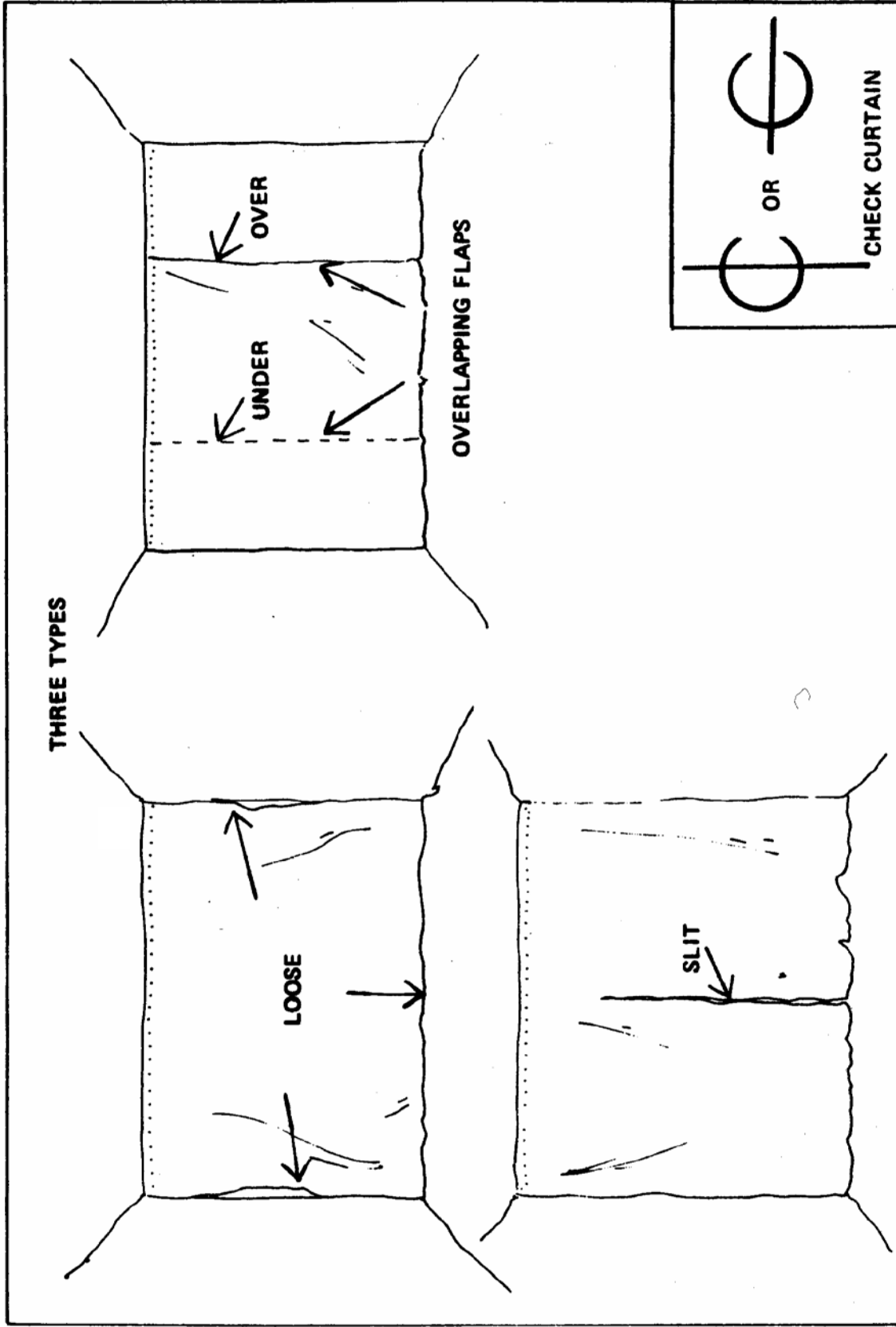

Visual 3 Check Curtains or Run-Through Checks



[This Page Intentionally Left Blank]

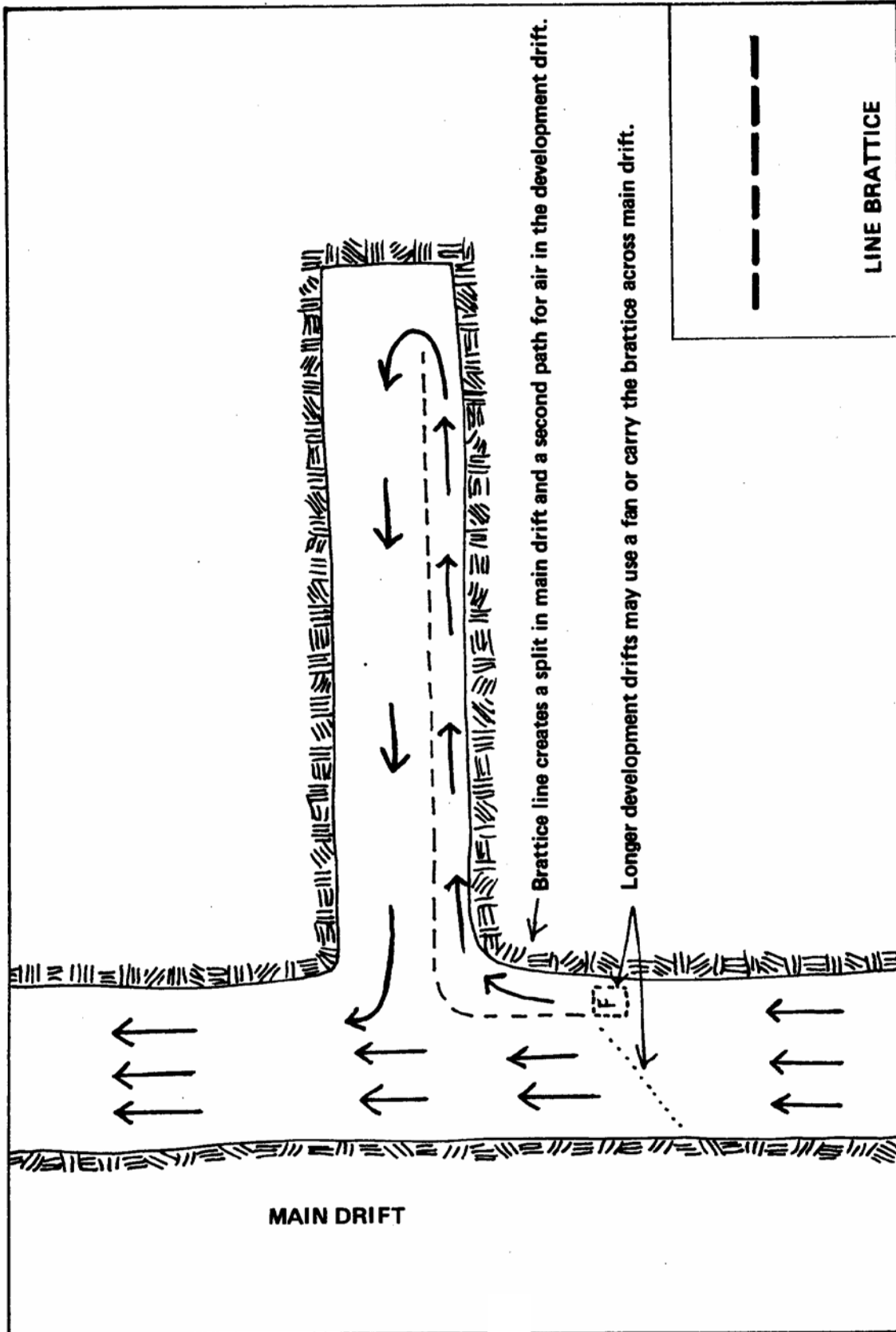

Visual 4

Line Brattice Multi-Level M

[This Page Intentionally Left Blank]

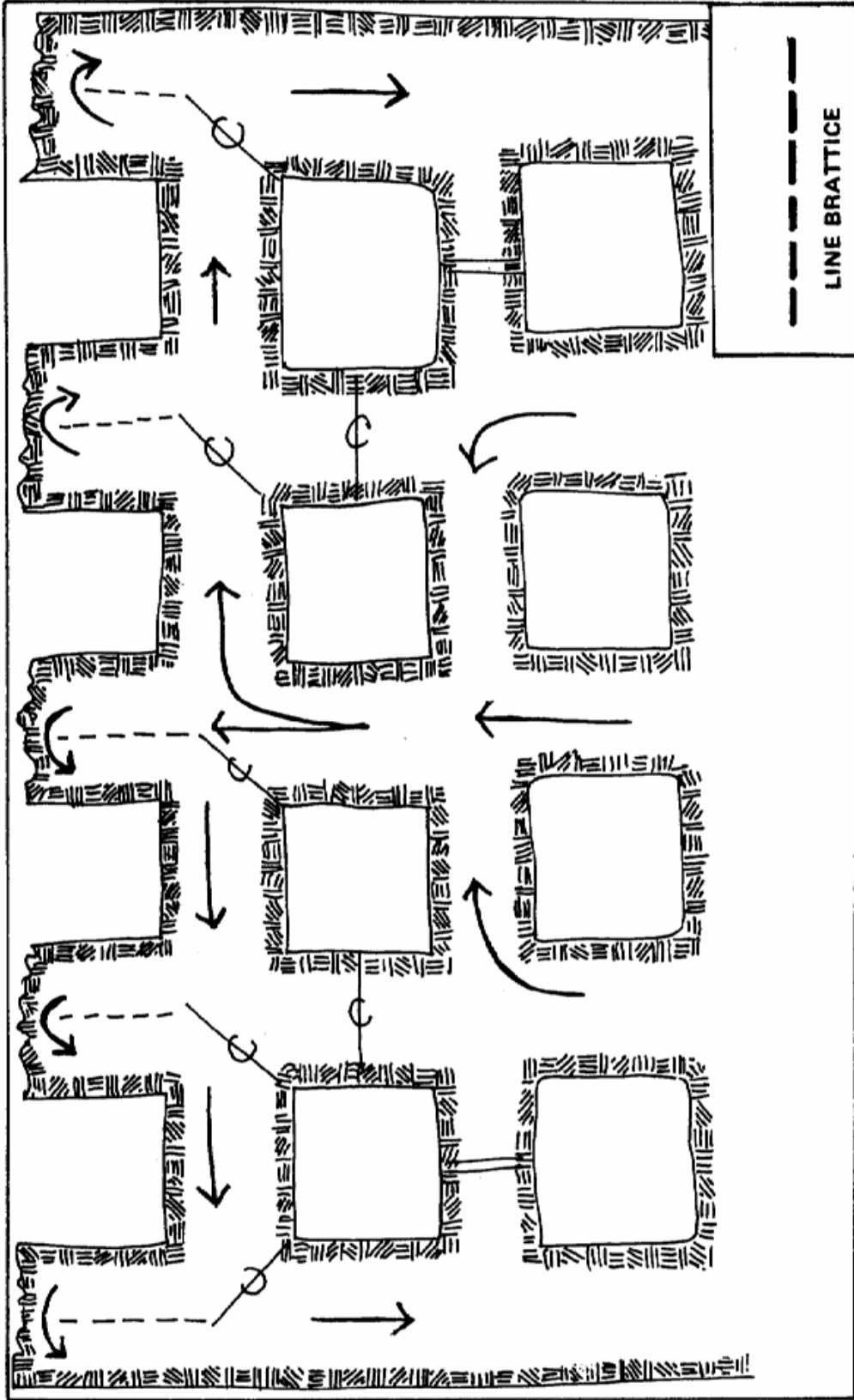

Visual 5 Line Brattice Single-Level, Room and Pillar Mine

[This Page Intentionally Left Blank]

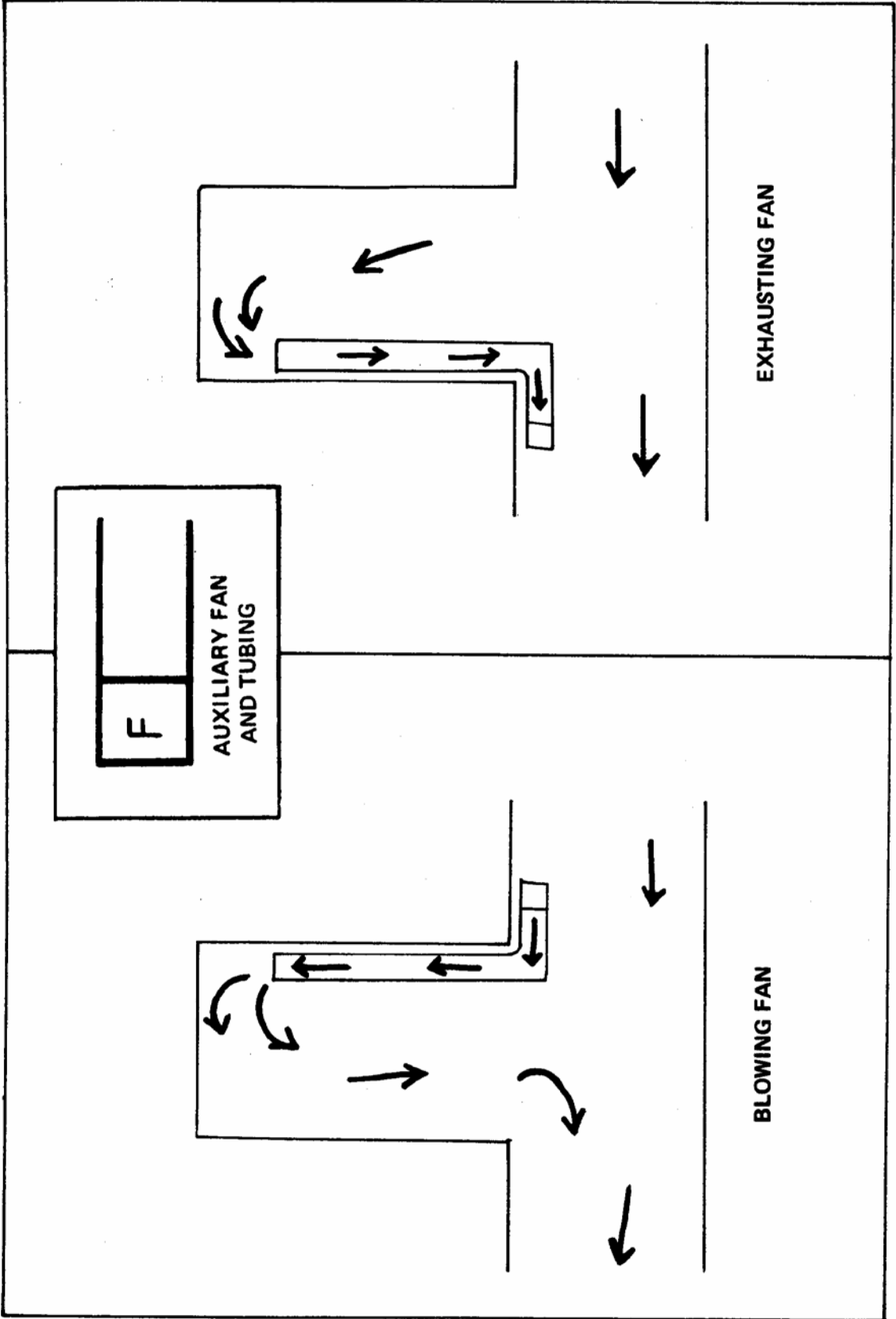

**Visual 6**

**Auxiliary Fan and Tubing**

[This Page Intentionally Left Blank]

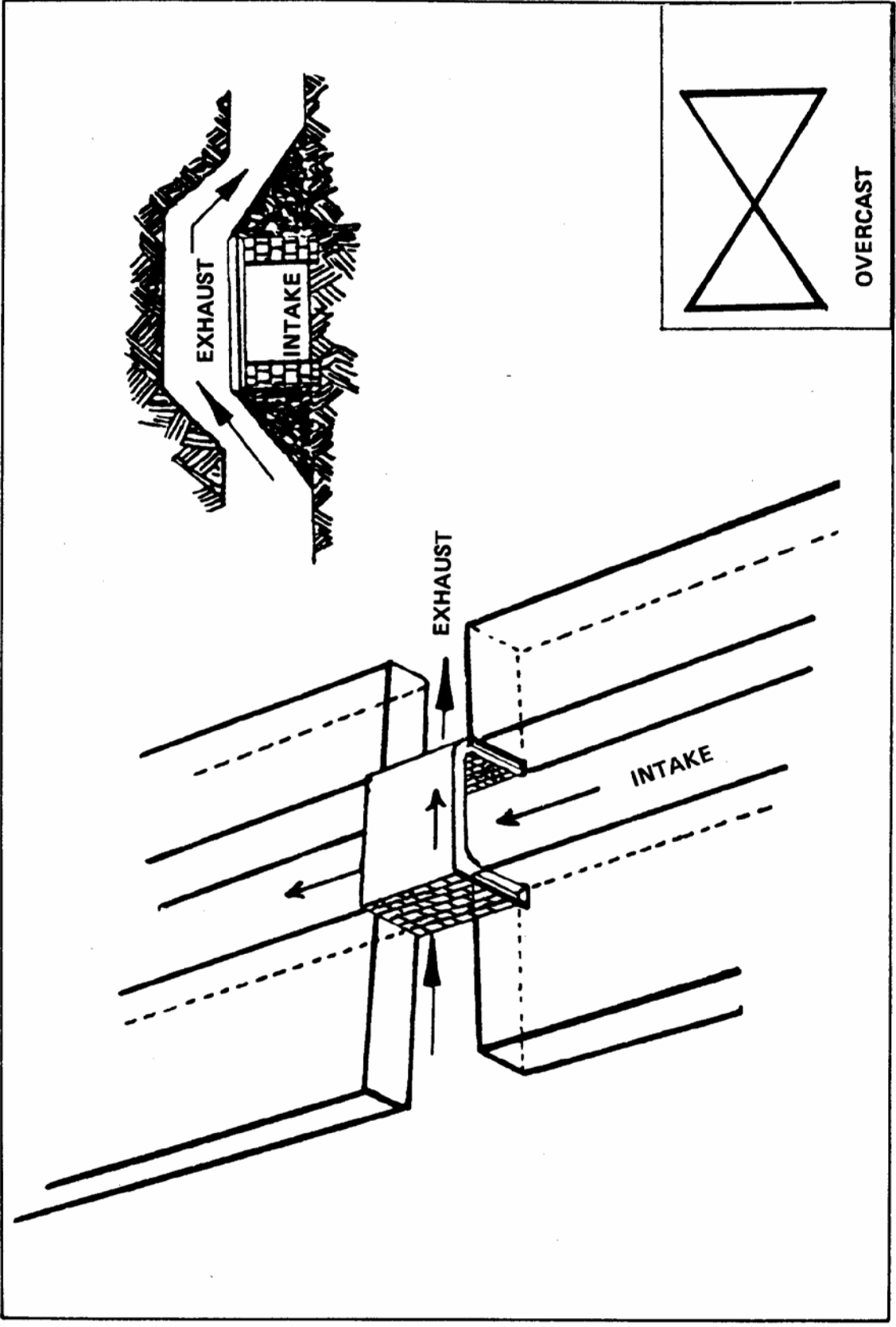

Visual 7

Overcast



[This Page Intentionally Left Blank]

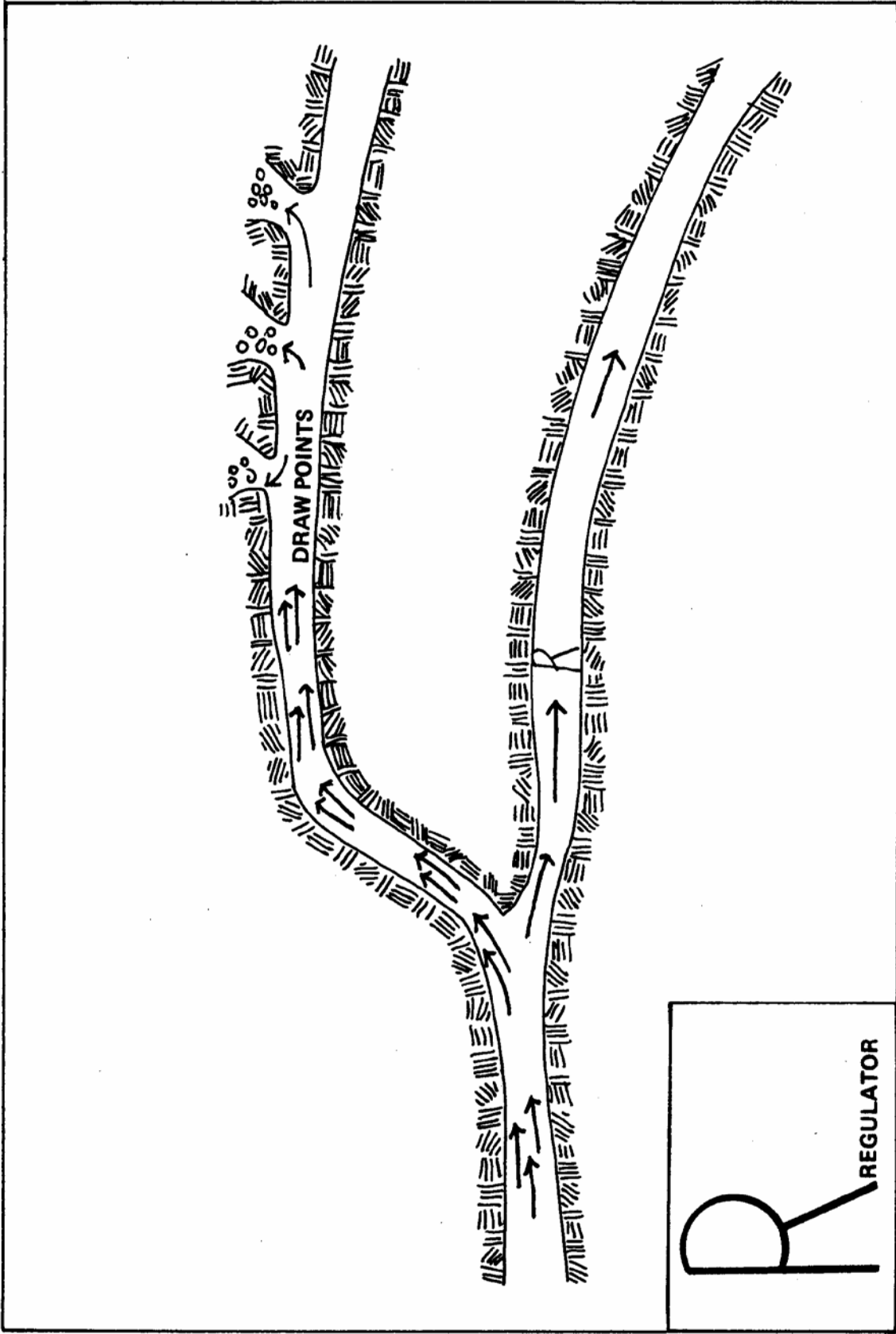

Visual 8

Regulator Multi-Level Mine

[This Page Intentionally Left Blank]

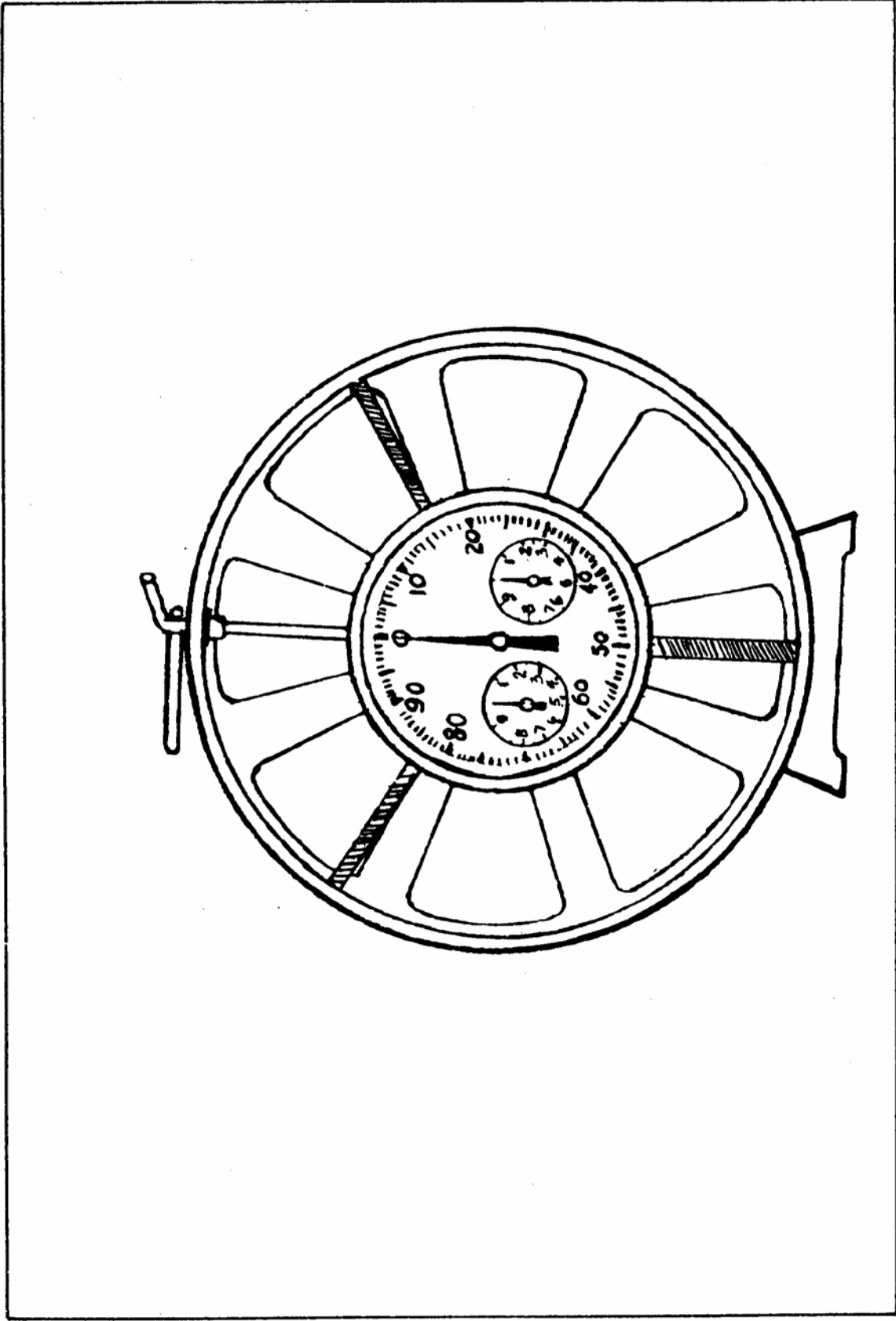

Visual 9

Anemometer

[This Page Intentionally Left Blank]

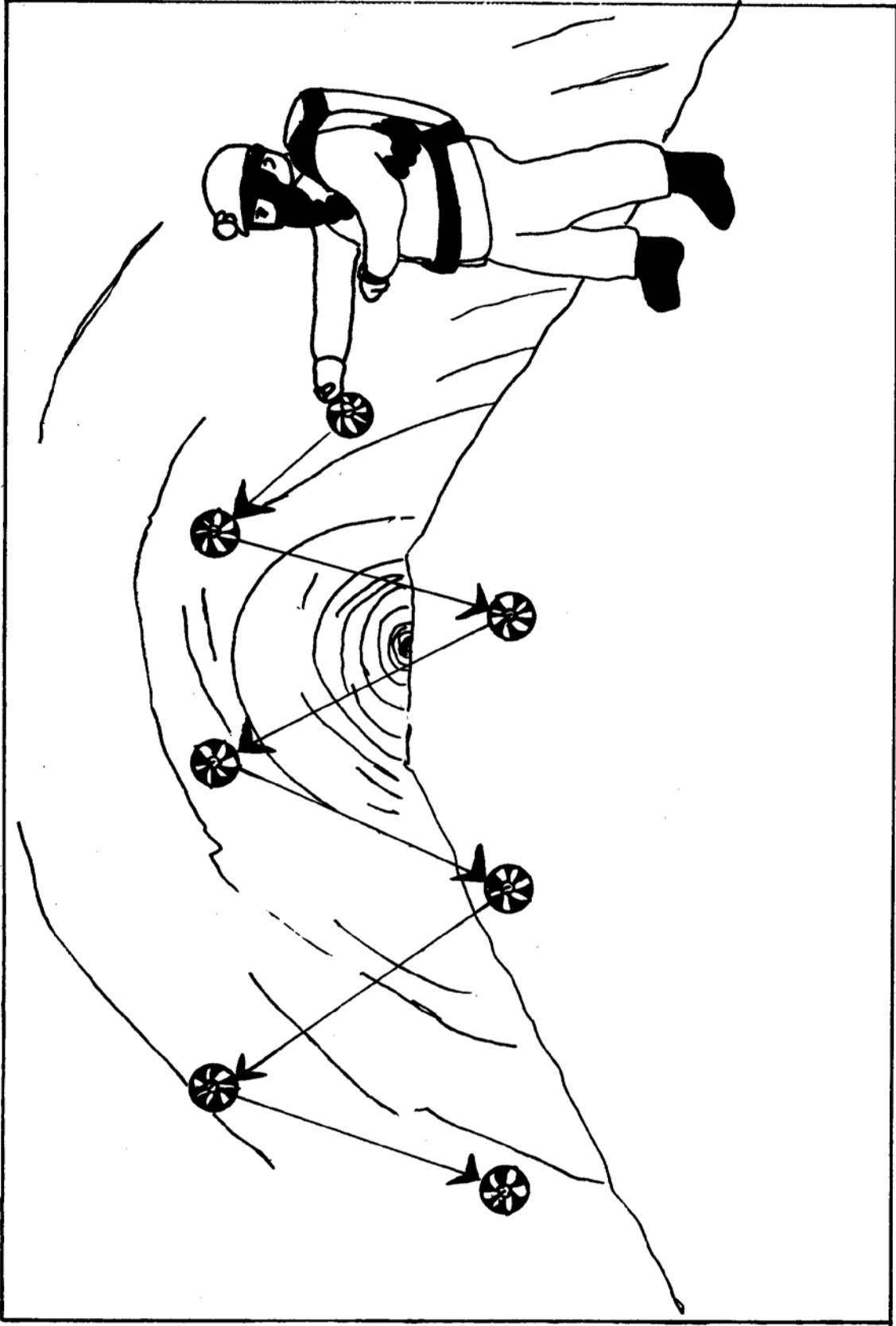

**Visual 10**

**Taking Anemometer Reading Using Traverse Method**

[This Page Intentionally Left Blank]

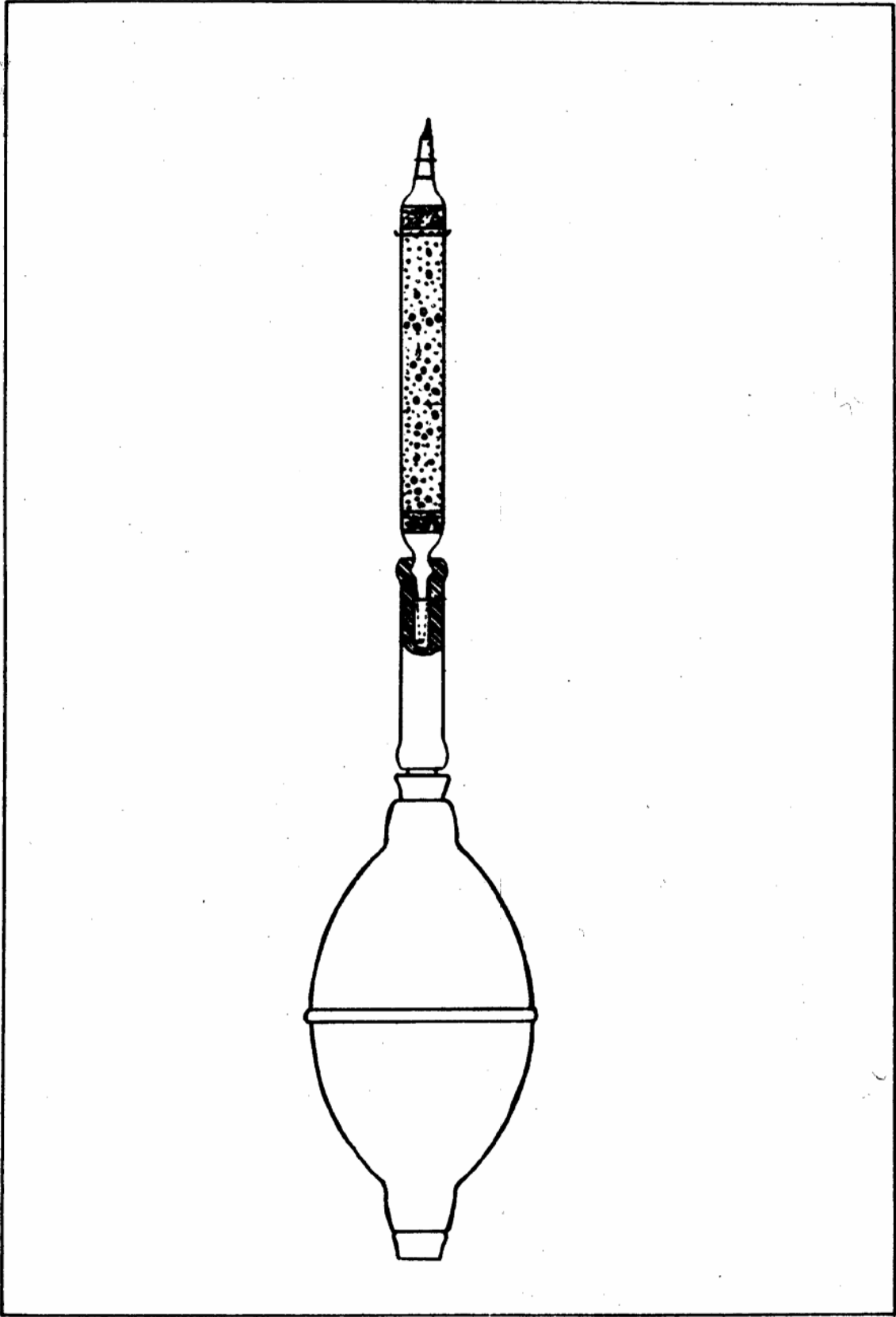

Visual 11

Smoke Tube



[This Page Intentionally Left Blank]

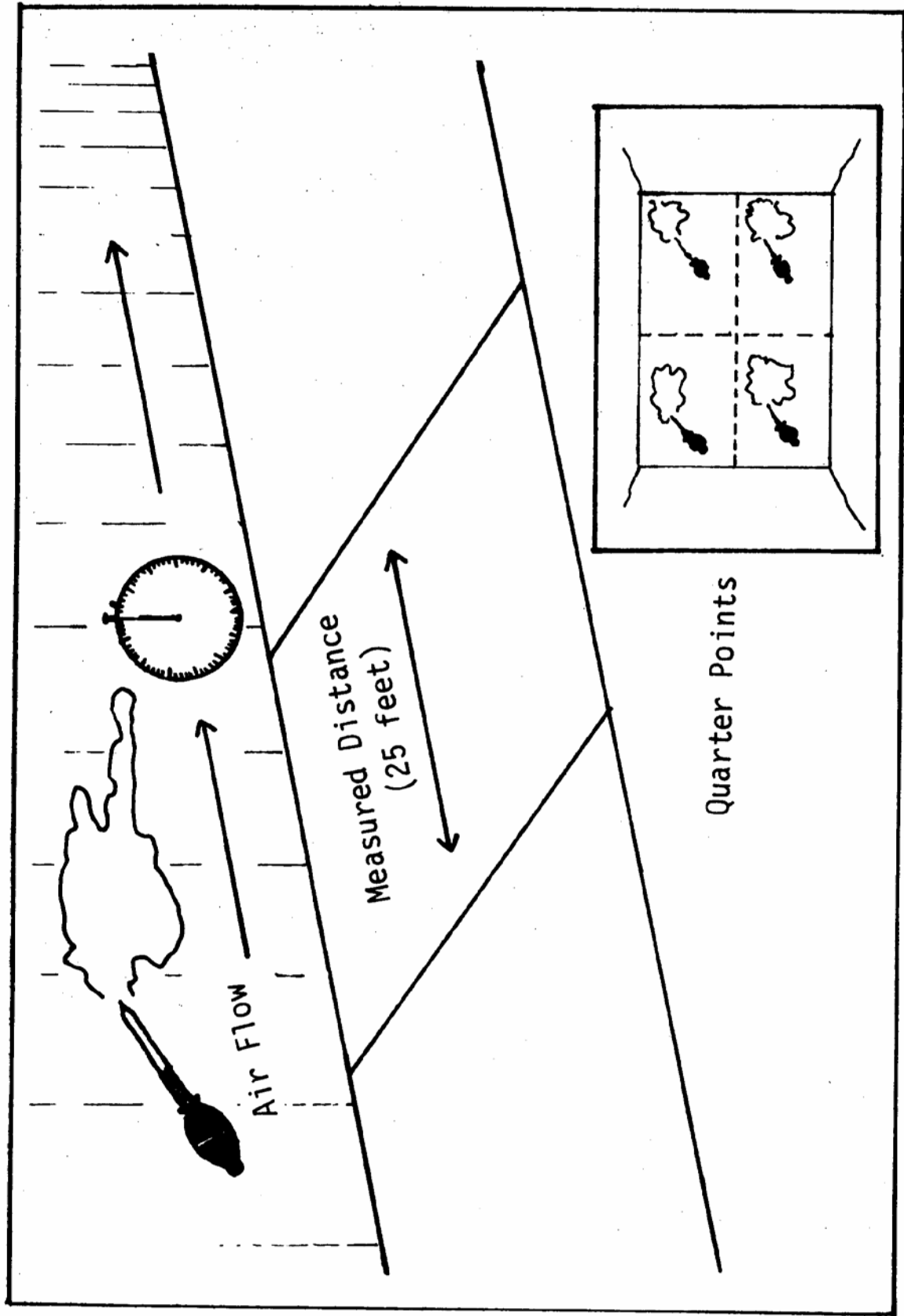

Visual 12

Taking Smoke Tube Reading

[This Page Intentionally Left Blank]

## **General Review Mine Ventilation**

Select the correct answer for each question below.

1. A smoke tube is a device used to:
  - a. Determine oxygen content of the mine atmosphere.
  - b. Determine direction and velocity of airflow.
  - c. Detect carbon monoxide.
  - d. Detect leaks in temporary bulkheads.
  
2. The traverse method is used when:
  - a. Taking a reading with a smoke tube.
  - b. Taking a reading with an anemometer.
  - c. Erecting a temporary bulkhead.
  - d. None of the above.
  
3. Mine rescue teams should alter existing ventilation:
  - a. Only when directed to do so by the command center.
  - b. When the team captain decides to do so.
  - c. When they encounter high concentrations of carbon monoxide.
  - d. When they encounter smoke.
  
4. Mine rescue teams erecting temporary bulkheads in atmosphere with elevated hydrogen or methane readings should:
  - a. Use only inflatable seals.
  - b. Leave a corner of the bulkhead open for the hydrogen or methane to exit.
  - c. Use non-sparking tools and nails.
  - d. Never enter such atmosphere.
  
5. During rescue team explorations, the main fan:
  - a. Should be kept running.
  - b. Should be continually monitored.
  - c. Both of the above.
  - d. None of the above.
  
6. Air locks are used by mine rescue teams:
  - a. To establish a fresh air base.
  - b. When opening a door or knocking out a bulkhead behind which conditions are not definitely known.
  - c. Before opening a barricade in bad air behind which trapped miners may be located.
  - d. All of the above.

7. Two instruments commonly used to measure velocity of airflow in a mine are:
  - a. Flame safety lamp and smoke tube.
  - b. Smoke tube and CO detector.
  - c. Anemometer and flame safety lamp.
  - d. Smoke tube and anemometer.
  
8. Temporary bulkheads built in a passageway should be placed at least 4 to 6 feet into the passageway in order that:
  - a. Sufficient space is available to construct a permanent bulkhead.
  - b. It will be protected from further explosions.
  - c. It will not be affected by fire if a fire should spread to that passageway.
  - d. All of the above.
  
9. "Pogo sticks" are devices that are used:
  - a. To test ground conditions.
  - b. To measure air velocity.
  - c. To determine direction of airflow.
  - d. As supports on which brattice cloth can be hung.

10. Match the term with its correct symbol:

**Note:** These are not standard symbols. If your mine uses different symbols, be sure to substitute your own here.

(1) Temporary bulkhead



(2) Line brattice



(3) Overcast



(4) Main fan



(5) Man door

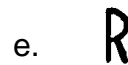

(6) Permanent bulkhead

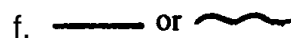

(7) Regulator

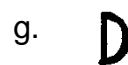

General review answers:

1. b
2. b
3. a
4. c
5. c
6. d
7. d
8. a
9. d
10. (1) f  
(2) j  
(3) a  
(4) c  
(5) i  
(6) h  
(7) e

[This Page Intentionally Left Blank]

## Glossary

**Air lock** – An area in the mine closed at both ends by two by two doors or two bulkheads with flaps or doors in them. An air lock is used to prevent mixing of different atmospheres while still permitting miners to enter and exit.

**Air shaft** – Shaft used exclusively for conducting air.

**Air split** – The division of an air current into two or more parts.

**Airway** – Any passage through which air is flowing.

**Anemometer** – Instrument used for measuring medium-velocity (120-2,000 ft./min.) and high-velocity (2,000-10,000 ft./min.) air currents in the mine.

**Area** (of an airway) – Average width multiplied by average height of an airway, expressed in square feet.

**Auxiliary fan** – A small, portable fan used to supplement the ventilation of an individual working place.

**Bulkhead** – A wall or partition constructed of incombustible material across a passageway to direct the ventilating air in its proper course.

**Check curtain or run-through check** – Brattice cloth, canvas, or plastic curtain used to deflect or direct air into a working place. Constructed in a manner to allow the passage of miners and machinery.

**Crosscut** – For single-level, room-and-pillar mines: A passageway driven at right angles between an entry and its parallel aircourse (or aircourses) for ventilation purposes. For multi-level mines: A tunnel driven perpendicular to the main vein system of the mine.

**Drift** – A mine opening, usually not intersecting the surface, that follows the direction of the vein (often within the vein).

**Downcast** – Intake ventilation shaft.

**Exhaust** – The air course along which the ventilated air of the mine is returned or conducted to the surface.

**Exhaust air** – The air that has passed through all the working areas and is on its way out of the mine.

**Face** – The principal operating place in a mine; the working place where fresh ore or mineral is exposed and extracted



**Intake** – The passage through which fresh air is drawn or forced into a mine or to a section of the mine.

**Irrespirable** – Unfit for breathing.

**Line brattice or brattice cloth** – Fire-resistant fabric or plastic partition used in a mine passage to direct the air into the working place. Also termed “line canvas.”

**Main fan** – a mechanical ventilator installed at the surface which operates by either exhausting or pushing to induce airflow through the mine.

**Man door** – Door installed in a permanent bulkhead to allow persons to pass through.

**Mine door** – A large hinged door used to close off a mine passage. Doors are usually installed in pairs to form an airlock.

**Overcast** – Enclosed airway built at an intersection of mine passages that permits one air current to pass over another air current without mixing.

**Quadrant** – Any of four quarters into which something is divided.

**Reagent** – A substance that causes chemical activity.

**Regulator** – An adjustable door or opening in a bulkhead, or a partially open mine door, used to control and adjust the quantity of airflow in the mine in order to ensure proper distribution.

**Return** – See *exhaust*.

**Smoke tube** – Instrument used for determining direction and velocity of slow-moving air (below 120 ft./min.).

**Stopping** – See *bulkhead*.

**Traverse** – To move across. A traverse measure of air velocity is one that is taken by walking across an airway.

**Undercast** – An enclosed airway built at an intersection of mine passages that permits one air current to pass under another air current without mixing.

**Upcast** – Exhaust ventilation shaft.

**Velocity** – Rate of airflow in linear feet per minute.

[This Page Intentionally Left Blank]

**A Guide to  
Mine Rescue Training –  
Metal and Nonmetal**

**Exploration**

**Module 4**

## Table of Contents

Course Objectives .....	4-1
Course Materials .....	4-2
Course Outline .....	4-3
Instructor Notes and Suggested Lecture .....	4-5
Visuals.....	4-35
General Review.....	4-49
Glossary .....	4-53

# Course Objectives

## Main Objective

The mine rescue team members will be able to prepare for and perform underground explorations under rescue and recovery conditions.

## Supportive Objectives

The team members will:

- Define exploration and explain its purpose.
- Identify the necessary components of a fresh air base and the procedures for establishing and advancing a fresh air base.
- Identify the types of equipment used by teams in various mine rescue situations.
- Define briefing and debriefing, explain why these sessions are held, and identify the information that should be included in them.
- Identify and demonstrate proper communication procedures.
- Identify and demonstrate proper traveling procedures.
- Identify and demonstrate proper testing procedures.
- Explain the purpose of progress reporting, identify the items covered in a progress report, and demonstrate the procedure.
- Explain the purpose of mapping, identify the items a team will map, and demonstrate proper mapping procedures.

## Course Materials

### Required:

- Handouts and visuals from the back of this module
- Pencil and paper for each team member
- Mine Rescue Activity Book

### Suggested:

- Communication equipment team uses
- Gas testing devices team uses
- Linkline
- Mapboard
- Laptop computer
- PowerPoint program
- Chalkboard or flipchart

## Course Outline

- I. Introduction
- II. Examination of mine openings
- III. Barefaced exploration
- IV. The fresh air base
  - A. Establishing a fresh air base
  - B. The fresh air base coordinator
  - C. Advancing the fresh air base
- V. Apparatus teams
  - A. Team's role in exploration
  - B. Equipment
    - 1. Team member's equipment
    - 2. Team equipment
      - a. What the law requires
      - b. Other
- VI. Briefing
- VII. Going underground
  - A. Captain's responsibilities
  - B. Getting under oxygen
- VIII. Exploration procedures
  - A. Team check
  - B. Communications
    - 1. Team signals
    - 2. Communication with the fresh air base
    - 3. Backup communication system

- C. Traveling procedures
    - 1. Advancing and tying in
    - 2. Order of travel
    - 3. Rate of travel
    - 4. Traveling in smoke
    - 5. Traveling through ventilation controls
    - 6. Traveling through water
    - 7. Crawling or climbing
    - 8. Marking route of travel
    - 9. Marking areas explored
  - D. Ground testing
    - 1. Visual inspections
    - 2. Checking back and sides
  - E. Testing for gases
  - F. Progress reporting
  - G. Mapping
  - H. Return to the fresh air base
- IX. Debriefing



# Instructor Notes and Suggested Lecture

## Introduction

**Note:** Because of the large diversity of minerals and ores mined in metal/non-metal mines and the diversity of mining techniques used, terminology will vary somewhat from operation to operation. Consequently, the mining terminology used in this training module may or may not agree completely with the terms used in your area. It may be necessary, therefore, for you to adapt and change some of the terminology to suit the needs of your team. For example, in salt mines, the term "back" (used throughout this module) will have to be changed to "roof." Also, metal/nonmetal operations vary from multi-level mines to single-level, room-and-pillar mines. There will be references in the lecture to each type of operation and sometimes separate visuals. Use the material that applies to your operation.

"Exploration" is the term we use to describe the process of assessing conditions underground and locating miners (or clues to their whereabouts) during a rescue or recovery operation.

Exploration is a broad topic. We'll be talking about preparations for explorations, team briefings and debriefings, standard procedures for advancing inside the mine, and the equipment you'll be using during exploration.

**Note:** Rescuing survivors and recovering bodies is covered in Module 6 *Rescue of Survivors and Recovery of Bodies*.

## Examination of Mine Openings

Before anyone goes underground, it's important to examine the mine openings to determine the safest route for entering the mine. Tests should be made for the presence of gases, and someone should make ventilation checks.

Whenever possible, it's best to enter the mine by way of the safest intake airway. In a shaft mine, check the cage to make sure it's operating properly. To test an automatic elevator, run it up and down the shaft manually several times.

Tests should also be made for the presence of gases, smoke, or water in the shaft. If a mine has had an explosion, the cage, signaling devices, and headframe may be damaged. You may have to use a mucking bucket or other improvised means to make your descent provided all five team members will fit. However, a cage should be made available as soon as possible.

## **Barefaced Exploration**

In some disaster situations, conditions may make it possible to conduct an initial exploration without self-contained breathing apparatus. This is known as “barefaced” exploration. Often, barefaced exploration is conducted with apparatus on team members, ready to function. This allows the team to quickly put on their facepieces and get under oxygen if conditions make it necessary.

Barefaced exploration should be conducted only when the ventilation system is operating properly and frequent gas tests indicate that there is sufficient oxygen and no buildup of carbon monoxide or other dangerous gases. A backup crew with apparatus should be stationed outside the area, ready to go in immediately to rescue the others if necessary.

The purpose of such exploration is to quickly establish the extent of damage and to progress to the point where apparatus teams can continue the exploration. Locomotives can be used during barefaced exploration as long as there is no smoke and no evidence of explosive gases. Usually, two locomotives are used in case one breaks down.

During barefaced exploration, the crew uses the mine’s communication system to report their progress and findings to the surface. This lets the backup team know where the barefaced team is located and whether it’s necessary to go in after them.

Barefaced exploration should stop at any point where disruptions in ventilation are found, or when gas tests indicate the presence of any carbon monoxide or other noxious gases, elevated readings of explosive gases, or an oxygen deficiency. A barefaced crew should also stop exploration when they encounter smoke or damage.

A fresh air base is usually established at the point where conditions no longer permit barefaced exploration. Because the area has already been explored, rescue team members and backup personnel are then free to travel to and from the fresh air base without apparatus. Teams equipped with apparatus and under oxygen continue exploration beyond the fresh air base.

## **The Fresh Air Base**

The fresh air base is the base of operations from which rescue and recovery work advances into irrespirable atmospheres. This is where apparatus crews begin their exploration of the affected area.

The fresh air base also functions as a base of communications for the operation linking the team, the command center, and all support personnel.

## Establishing a Fresh Air Base

Often, the operation's initial fresh air base will be established somewhere underground. But in some mines, especially shaft mines, it may be necessary to establish the initial fresh air base on the surface. Sometimes the fresh air base will remain on the surface throughout the entire operation.

Whether you put it underground or on the surface, the fresh air base should be located as close as possible to the affected area of the mine, but situated where it's assured a supply of good air.

Underground, existing refuge chambers are sometimes used as fresh air bases. Or, a fresh air base can be set up in a drift, entry (for single-level, room-and-pillar mines), or crosscut close to the affected area. In these cases, an air lock must be built to isolate the fresh air base from the unexplored area beyond it. The air lock allows teams to enter and exit the unexplored area without contaminating the air in the fresh air base.

Here are some specific factors to consider when you select a site for a fresh air base:

1. Be sure the fresh air base is located where it's assured positive ventilation and fresh air.
2. If the fresh air base is underground, it should be located where it's assured a fresh air travelway to the surface. This travelway will be used to safely move people and supplies to and from the fresh air base. If possible, there should also be transportation available.
3. The site should be situated where it can be linked to the command center by means of a communication system.
4. There should also be a communication system to link the team and the fresh air base.

These four are probably the most important factors that help determine where to establish a fresh air base, but there are also some other elements to take into consideration. For example, the area should be free of oil and grease. Also, the fresh air base should be large enough to accommodate all the people who will be using it and allow enough space for them to work efficiently.

It is often recommended that all possible electrical conductors (track, pipe, wires, etc.) be severed so that the affected area beyond the fresh air base is isolated from any possible stray or direct current.

The fresh air base is normally outfitted with supplies and other equipment to be used during the operation. For example, a typical fresh air base will probably be equipped with gas testing devices, equipment for detecting oxygen deficiency, and perhaps fire-fighting equipment.

There may also be first aid supplies and oxygen therapy equipment at the fresh air base, as well as tools and replacement parts for self-contained breathing apparatus. There should also be a map of the affected area. If possible, the fresh air base should be supplied with benches, canvas, or brattice cloth on which the backup team can set their apparatus.

**NOTE TO TRAINER:** According to the nature of the emergency, other equipment or supplies may be kept at the fresh air base. Point this out to the team members.

## **The Fresh Air Base Coordinator**

Stationed at the fresh air base, there will be a person who is responsible for establishing and maintaining orderly operations. This is the “fresh air base coordinator.”

There will also probably be an advisory committee at the fresh air base to help the coordinator. This committee is usually composed of Federal and state officials, and union representatives, if involved. Sometimes, “runners” are stationed at the fresh air base to carry messages from the fresh air base to the command center in the event of a communication breakdown. The runners may also be responsible for other chores, such as taking gas samples to the surface or monitoring the communication system cable.

**NOTE TO TRAINER:** Refer to Visual 2 as you discuss the following list of the coordinator’s responsibilities. Use this visual as a PowerPoint, chalkboard sketch, or handout.

The main responsibilities of the fresh air base coordinator are:

1. Maintaining communications with the working rescue team and the command center.
2. Following the team’s progress on the mine map and marking findings on the map as the team reports them.
3. Coordinating and overseeing the activities of all personnel who are at the fresh air base, including the advisory committee.

Fulfilling these three basic responsibilities involves performing a number of duties. The coordinator carries out many of these duties. Some of the tasks may be delegated to other individuals, but it’s the coordinator’s responsibility to see that they’re carried out.

Let's take a look at the fresh air base coordinator's responsibilities during a typical operation.

An incoming coordinator who is replacing another coordinator should get all necessary information from the outgoing coordinator to ensure that the changeover goes smoothly. It's also the incoming coordinator's duty to check communications between the fresh air base and the command center to make sure the system is operating properly. The coordinator also usually reports his or her arrival at the fresh air base, and logs the arrival time.

In addition to this, the coordinator's duties typically include checking the name or number of the team going into the affected area to work, checking the condition of the backup team, and checking and logging equipment and materials. The coordinator should also make sure there is a map of the affected area at the fresh air base.

A fresh air base coordinator is normally responsible for logging the times that all personnel enter and leave the fresh air base, and for logging the time and nature of all telephone calls. As work progresses, the fresh air base coordinator monitors communications from the working team, relays instructions from the command center to the team, and provides information to the backup team based on reports received.

It's also usually the coordinator's responsibility to make sure someone is stationed at the fresh air base to monitor the team's communication cable if this type of communication system is being used. This person should help to unroll the cable as the team advances and roll it back up as the team retreats. The coordinator should also make sure the requirements for a fresh air base are constantly maintained. It is typically the coordinator's responsibility to make sure that no unauthorized personnel are permitted to go beyond of the fresh air base.

As you can see, the fresh air base coordinator plays a key role in ensuring that the entire operation runs smoothly and efficiently. The coordinator maintains crucial communication links with the command center and the working rescue team. In addition, the coordinator is responsible for just about everything that goes on at the fresh air base.

Because the coordinator's job is such an important one, it is absolutely essential that everyone at the fresh air base respect the coordinator's authority and do whatever they can do to help out. In order to make the fresh air base coordinator's job a little easier, it's also essential that only those people necessary to the operation are permitted at the fresh air base.

**NOTE TO TRAINER:** Stress this important point: Only those people necessary to the operation should be permitted at the fresh air base.

## Advancing the Fresh Air Base

**Note:** Advancing the fresh air base applies mainly to single-level mines. In multi-level mines, the fresh air base is often set up in one place and remains there throughout an operation.

In single-level mines using the room-and-pillar system, the fresh air base is usually advanced closer to the affected area of the mine as soon as areas forward of the base are explored and re-ventilated. This ensures that the apparatus crews will begin their explorations as close as possible to the affected area of the mine.

**NOTE TO TRAINER:** Refer to Visual 3 as you explain to the team how to advance a fresh air base. Use this visual as a PowerPoint, chalkboard sketch, or handout.

To advance the fresh air base, the team will have to build a new air lock at the site of the new fresh air base and put up any additional temporary bulkheads in parallel entries that are needed to seal off the area at that point so that fresh air can be advanced.

**Note:** Bulkhead and stopping are interchangeable terms. The word “bulkhead” will be used in this lecture. If your mine uses “stopping,” substitute that term for “bulkhead” throughout the lecture.

Also, the team will have to repair any damaged ventilation controls in the area between the old fresh air base and the new one. However, be sure to make the necessary adjustments for directing air to an exhaust airway. This ensures that the area can be properly flushed out and ventilated. Next, return to the old fresh air base and remove or open that air lock and any bulkheads in parallel entries. This permits air to enter and flush out the area up to the new fresh air base.

Before everyone is moved up to the new fresh air base, the area between the old and the new base should be explored by a team. Using appropriate gas testing devices, the team should check all dead ends, intersections, and high places in the area to make sure it's adequately ventilated.

**Note:** If gases are found to have accumulated in areas that are difficult to flush by means of regular ventilation (very high or low spots, etc.), it may be necessary to use line brattice to channel the flow of air directly into these areas. The team or crew may do this simply by holding up the brattice so that it directs air into the places where the gases have collected.

Once the entire area is explored, all appropriate checks have been made, and the area is declared safe, the team and other fresh air base personnel can move up to the new fresh air base.

**Review questions:** Ask the team members the following questions and allow time for them to answer. Discuss the answers with them so they fully understand the material covered in this section.

1. What is a fresh air base?

The fresh air base is the base of operations and starting point for rescue and recovery work into irrespirable atmospheres.

2. What are some of the requirements for a fresh air base?

If underground, the fresh air base must be situated where it's assured of positive ventilation, a supply of fresh air, and a travelway to the surface for people and equipment. A fresh air base should have communications systems linking it to the command center and to the mine rescue team. It is also best if the area is free of oil and grease.

3. What are the three main duties of the fresh air base coordinator?

The fresh air base coordinator handles communications with the team and the command center, maps the team's progress and findings, and coordinates and oversees the activities of all personnel at the fresh air base.

4. How do you advance a fresh air base in single-level, room-and-pillar mines?

To advance the fresh air base, construct a new air lock and any bulkheads in parallel entries that are needed, repair ventilation controls to the point where the new fresh air base is located, and provide an opening to the exhaust. Then return to the old fresh air base and remove that air lock and any bulkheads in parallel entries in order to ventilate the new area. Prior to moving everyone up to the new fresh air base, a crew should perform gas tests in all dead ends, intersections, and high places of the newly ventilated area.

## Apparatus Teams

Once the fresh air base is established, apparatus teams will begin to explore the affected area. This exploration may require only one or two trips, or it may continue through many team rotations. How many trips will be needed to complete the exploration (and how long it will take) will depend on the extent of the area involved and the conditions within the affected area.

## Team's Role in Exploration

During exploration, the rescue team travels in potentially hazardous atmospheres. As the team progresses through the mine, team members make gas tests and assess conditions. The team also searches for clues as to where survivors may be located, and locates fires. All these findings are mapped and reported to the fresh air base as the team proceeds.

As you explore, keep in mind that your first priority is team safety. The rescue of survivors comes second. Your third priority is the recovery of the mine. During exploration, teams will work according to a rotation schedule. One team, for example, will be scheduled to work. A second team will be stationed at the fresh air base as the "backup team," and a third team, known as the "standby," will be ready and waiting on the surface. Other teams may be scheduled to rest.

**Note:** While a team is "at rest," it's important to allow enough time for their apparatus to be cleaned, tested, and prepared for use (and repaired, if necessary).

Because rescue work is strenuous and demanding, it's important for team members to be well rested. It's also recommended that you don't eat within one hour of the time you'll be wearing your apparatus, and you shouldn't drink alcoholic beverages for at least 12 to 18 hours before you get under oxygen. Lack of sleep, a recent meal, or alcoholic beverages can cause you to be sluggish and impair your judgment and reflexes. It's also a good idea to limit intake of stimulants such as coffee, colas, etc., because these substances increase heart and respiration rates.

## Equipment

**NOTE TO TRAINER:** At this point, tell the team exactly what types of gas detectors and oxygen-testing devices they will use during exploration. Also specify what form of communication system they will use.

Rescue team members use some of the same basic equipment that any underground miner uses. For example, each member will be outfitted with a hard hat, cap lamp, steel-toe shoes or boots, and a metal ID tag. For rescue work, you will also wear a metal ring on your mine belt so you can hook onto a linkline, and it is common practice for everyone to wear a watch. Of course, each team member will also wear a self-contained breathing apparatus.



## Team Equipment – What the Law Requires

Some of the equipment your team will use for exploration is required by law. For example, remember that the law requires your rescue station to be equipped with four gas detectors for each type of gas you may encounter and two oxygen indicators.

According to law, the team must also have a portable or sound-powered communication system. The system's wire or cable must be at least 1,000 feet long, and it must be strong enough to be used as a manual communications system.

**EQUIPMENT RULE REFERENCE:** Title 30 Code of Federal Regulations

### **30 CFR Section 49.6(a):**

**(a)** Each mine rescue station shall be provided with at least the following equipment:

- (1) Twelve self-contained breathing apparatus, each with a minimum of 4 hours capacity (approved by MSHA and NIOSH under 42 CFR Part 84, Subpart H), and any necessary equipment for testing such breathing apparatus;
- (2) A portable supply of liquid air, liquid oxygen, pressurized oxygen, or oxygen generating chemicals, and carbon dioxide absorbent chemicals, applicable to the supplied breathing apparatus and sufficient to sustain each team for eight hours while using the breathing apparatus during rescue operations.
- (3) Two extra, fully-charged oxygen bottles for every six self-contained breathing apparatus;
- (4) One oxygen pump or a cascading system, compatible with the supplied breathing apparatus;
- (5) Twelve permissible cap lamps and a charging rack;
- (6) Four gas detectors appropriate for each type of gas that may be encountered at the mines served. Gas detectors must measure concentrations of methane from 0.0 percent to 100 percent of volume, oxygen from 0.0 percent to at least 20 percent of volume, and carbon monoxide from 0.0 parts per million to at least 9,999 parts per million.
- (7) [Reserved].
- (8) One portable mine rescue communication system (approved under part 23 of this title) or a sound-powered communication system.
  - (i) The wires or cable to the communication system shall be of sufficient tensile strength to be used as a manual communication system.
  - (ii) These communication systems shall be at least 1,000 feet in length.

(9) Necessary spare parts and tools for repairing the breathing apparatus and communication system.

**(b)** Mine rescue apparatus and equipment shall be maintained in a manner that will ensure readiness for immediate use.

(1) A person trained in the use and care of breathing apparatus shall inspect and test the apparatus at intervals not exceeding 30 days and shall certify by signature and date that the inspections and tests were done.

(2) When the inspection indicates that a corrective action is necessary, the corrective action shall be made and the person shall record the corrective action taken.

(3) The certification and the record of corrective action shall be maintained at the mine rescue station for a period of one year and made available on request to an authorized representative of the Secretary.

## Other Equipment

Beyond what is required by law, the other equipment your team will use depends on the situation. For example, if you are rescuing survivors, the team will probably carry a stretcher or stokes basket, and an extra approved breathing apparatus for the rescued person. But if your task is to build ventilation controls, the team will probably carry tools and other construction equipment.

Some of the material you need to build ventilation controls may already be underground, so you will simply pick up what the team needs as you progress through the mine. This also applies to other team tasks that require the use of materials already inside the mine. The team simply picks up what it needs as it advances. The equipment your team uses beyond what the law requires is determined by what type of work you'll be doing.

**NOTE TO TRAINER:** The following list is an example of equipment typically used during exploration. You may need to adapt it to fit the needs of your team.

Specify what equipment the team most commonly uses, and explain what it is used for. Tell the team whether they'll usually carry the equipment along with them as they explore, or leave it at the fresh air base. Stress the fact that what they use will vary from one situation to another.

Here are some examples of equipment a mine rescue team might use:

- Gas detectors (or multi-gas detector)
- Oxygen indicator
- Communication equipment
- Linkline – This is a line or rope, usually equipped with rings, that is used to hook team members together in smoke.
- Mapboard and marker – The mapboard may be fitted with a plexiglass cover to protect the map from water damage in wet mines.
- Signaling devices (such as horns)
- Scaling bar
- Walking stick – The captain can use a walking stick to probe water depth or to avoid obstructions in heavy smoke.
- Stokes basket or stretcher  
**Note:** Even if there are no miners trapped underground, teams often use a stokes basket to carry equipment.
- First aid kit
- Fire extinguisher
- Tools – This usually includes a hammer, nails, axe, shovel, brattice cloth, and possibly a saw, and a wrench to open water line valves.  
**Note:** In potentially explosive atmospheres, use non-sparking tools, nails, etc.
- Blankets (if missing miners are involved)
- Extra approved breathing apparatus (if missing miners are involved)  
**Note:** Some teams use washers with streamers or flags attached for marking hazardous areas, such as bad back. Mention these items if your team uses them.
- Carpenter's apron – The captain may use an apron to carry a notebook, pen, and chalk. Other team members may use one for carrying nails, hand tools, etc.

## Briefing

Before the team goes underground, they will attend a briefing session. This usually takes place at the command center and is conducted by a briefing officer and a briefing committee. The briefing committee is generally composed of company and Federal officials and, where applicable, state and union representatives.

At the briefing, you should be told as much as possible about what has happened in the mine and what conditions currently exist. The briefing officer will give the captain the team's assignment. This assignment specifies what areas your team will explore and what you will be looking for. The briefing officer will also issue your team an up-to-date mine map and give you a time limit within which you should be able to complete your work and return to the fresh air base.

During the briefing, the briefing officer will try to give you whatever information is available. However, it is your responsibility as team members to be sure you have all the information you need to do your work. Before you begin exploration, you should have the answers to the following questions:

**NOTE TO TRAINER:** Distribute copies of Visual 4 and refer to it as you discuss this list of questions. You may also write the questions on a chalkboard or use as a PowerPoint.

1. Is the evacuation complete? Are any miners missing? If so, how many and what are their possible locations?
2. What is known about the cause of the disaster?
3. Is your team the first one to explore? (In multi-level mines, the team would also want to know if there are any other teams working on other levels.)
4. Have the shaft and hoist been checked and, if so, what condition are they in?
5. Have State and Federal officials been notified?
6. Are guards stationed at all mine entrances?
7. Is the ventilation system operating? Is it an intake or exhaust system? Are attendants posted at the surface ventilation controls? Have air samples been taken? If so, what are the results?
8. Will there be a backup team standing by at the fresh air base, and reserve teams on the surface?
9. What are the team's objectives and what is their time limit?
10. What conditions are known to exist underground?  
(Ground conditions, water, gas, etc.)
11. Is the mine's communication system operating? Is it being monitored?
12. Is power to the affected area on or off?
13. Is there diesel or battery-powered equipment or a charging station in the affected area?

**Note:** The team should be aware that battery-powered or diesel equipment may still be running even though power to the area has been cut off.

14. What type of equipment is in the area? Where is it located?
15. Where are compressed air and/or water lines located? Are they in operation? Are valves known to be open or closed?
16. What type of firefighting equipment is located underground? Where is it?
17. What tools and supplies are available underground? Where are they?
18. Are there storage areas for oil or oxygen, acetylene tanks, or explosives in the area to be explored?

## **Before Going Underground**

Before your team proceeds to the fresh air base, it is the captain's responsibility to make sure the team, its equipment, and its apparatus are ready to go. The captain should:

1. Check each team member to make sure they are physically fit to wear the apparatus and to perform rescue work.  
  
**Note:** In some cases, a doctor may be on hand to perform this check before the team enters the mine. Remind the team that bushy sideburns and beards prevent a good face-to-face piece seal, so they should not be worn by the apparatus team members.
2. Make sure that each team member's apparatus has been properly prepared and tested.
3. Make sure the team has all necessary tools and equipment (including the captain's own supplies, such as notebook, pencil, chalk, etc.).

Once the team arrives at the fresh air base, it's the captain's responsibility to make the final preparations and arrangements before the team proceeds beyond the fresh air base. The captain should:

1. Make sure the team members understand the briefing instructions and what their individual jobs will be.
2. Make sure the gas-testing equipment, the communication equipment, signaling equipment, and stokes basket or stretcher have been checked by the designated people.
3. Establish with the fresh air base coordinator what communications will be used.

4. Synchronize watches with the fresh air base coordinator.
5. If not the first team to explore, get up-to-date information from the last team (or from the coordinator) about how far the last team advanced and what they found.
6. Make sure your team's map person gets an updated map from the last team's map person or from the fresh air base coordinator.

## Getting Under Oxygen

Once all of these preparations and last-minute checks have been made, the team members are ready to put on their apparatus and get under oxygen.

**NOTE TO TRAINER:** At this point, review your team's procedure for getting under oxygen.

Once the team is under oxygen, the captain checks each team member and breathing apparatus. The co-captain performs the same checks on the team captain. When the checks are completed, the captain notifies the fresh air base coordinator that the team is ready to proceed, and asks permission to set out. Before the team leaves the fresh air base to begin exploration, the captain should be sure to take note of the time of departure. Some teams jot down the time on their map for later reference.

**Review questions:** Ask the team members the following questions and allow time for them to answer. Then discuss the answers with them so they fully understand the material covered in this section.

1. What equipment is a mine rescue team required to have?

In addition to the equipment any miner wears when going underground (i.e., hard hat, cap lamp, safety shoes, metal ID, and perhaps a watch), the team members wear breathing apparatus, and the team must have two detecting devices for each gas they may encounter, two oxygen indicators, and a communication system.

2. What information is normally covered in a team briefing and/or what questions should team members ask?
  - a. Evacuation report—missing miners and possible locations?
  - b. What may have caused the disaster?
  - c. Are they the first team to go underground? (In multi-level mines, the team would also want to know if there are teams working on any other level.)

- d. Have shaft and hoist been checked—what condition are they in?
  - e. Have State and Federal authorities been notified?
  - f. Is property guarded?
  - g. What is state of ventilation system (fans) and gas conditions at exhausts?
  - h. Is backup team available?
  - i. What are team's objectives and time limit?
  - j. What are known conditions?
  - k. What is status of mine's communication system?
  - l. Is power in mine on or off?
  - m. Is there diesel or battery-powered equipment or a charging station in the affected area?
  - n. What equipment is in the affected area?
  - o. What is location and/or condition of air and water lines?
  - p. What type of firefighting equipment is underground and where is it located?
  - q. Where are tools and supplies located underground?
  - r. Are there storage areas for oil, oxygen, acetylene tanks, or explosives in the area to be explored?
3. What checks and procedures should the team captain perform before the team travels to the fresh air base, and before the team travels beyond the fresh air base?
- a. Check each team member's physical condition.
  - b. Ensure that all apparatus are checked and operating properly.
  - c. Ensure that all needed tools and equipment are ready and working properly.
  - d. Ensure that all team members understand the instructions from the briefing session.
  - e. Establish with the fresh air base coordinator what communications will be used.

- f. Synchronize all watches.
- g. Obtain all necessary information from team coming out.
- h. Ensure that an up-to-date map is readied.
- i. Check apparatus of each team member after going under oxygen (proper functioning, good seal, each team member ready to go).

## **Exploration Procedures**

**NOTE TO TRAINER:** Before discussing this section, check your state's regulations regarding exploration. If necessary, adapt the training content to fit these regulations by adding and/or changing material where necessary.

Every exploration is different. Each one is an unknown situation, so each presents its own problems. Although it's difficult to tell exactly what you'll be doing during any exploration, there are some accepted procedures for carrying out basic exploration work.

These procedures have developed over the years as mine rescue teams gained experience. They should be thought of as "guidelines" rather than "rules" because they are fairly flexible. Let's take a look now at some of the standard techniques and procedures you'll use during exploration.

### **Team Check**

One standard procedure you'll use during an exploration is the "team check." There are three reasons for the team check:

- 1. To make sure each team member is fit and ready to continue;
- 2. To make sure each team member's apparatus is functioning properly; and
- 3. To give the team a chance to rest.

Usually, the captain conducts the team checks by simply halting the team briefly, asking each team member how he or she feels, and checking each apparatus. It's recommended that these team checks be conducted every 15 to 20 minutes. Under certain conditions, the team may not be able (or may not find it feasible) to stop this often.



It is also recommended that you make your first stop for a team check as soon as possible after leaving the fresh air base.

There is a good reason for stopping close to the fresh air base—If a team member is feeling unfit to travel or an apparatus is malfunctioning, the journey back to the fresh air base is relatively quick and easy at this point.

The captain usually notes each team member's gauge reading at each rest stop, and reports the lowest reading to the fresh air base. The lowest reading may then be used as a reference point to determine when the team should return to the fresh air base.

Keep in mind that in addition to checking each team member and apparatus, these stops allow the team a chance to rest. If your team is searching for survivors, you'll probably want to advance quickly, but rest stops are still important. Be sure to allow time for them. How long you stop for each check will be determined by the conditions you encounter and the work you are doing.

Rest stops are also important (perhaps more so) on the return trip. The team will usually be more tired once they've completed their work. Don't forget to allow time for team checks as you travel back to the fresh air base.

## Communications

As you travel beyond the fresh air base, communication plays an increasingly important role in your exploratory work. It is extremely important that teams develop an effective method of communicating among themselves and with the fresh air base.

## Team Signals

During exploration, talking among team members is generally kept to a minimum. Instead, team members use a system of signals to communicate among themselves. The signals are generally sent by means of some sort of signaling device, such as a horn.

**NOTE TO TRAINER:** Refer to Visual 5 as you discuss team signals. Use this visual as a handout, or write the information on a chalkboard.

The signals most commonly used are:

- One signal: Stop
- Two signals: Advance – move toward captain
- Three signals: Retreat – move toward No. 5 (last) person
- Four signals: Distress or emergency

Both the team captain, at the head of the team, and the No. 5 person do the signaling. It's standard practice for each to return the other's signal before anyone on the team moves. This ensures that the first and last persons in line have heard the signal, and that the entire team is ready to respond to the signal.

Be sure to use these signals as much as possible during your training sessions. If you practice them often enough, your response to them during an emergency will become almost automatic.

## **Communication with the Fresh Air Base**

As the team advances, it **must** stay in contact with the fresh air base at all times to report your team's progress and to receive further instructions. To communicate with the fresh air base, you will generally use either sound- or battery-powered communication equipment.

One team member, usually the No. 5 person, wears the equipment, and is responsible for sending information to the fresh air base and relaying instructions from the fresh air base to the team. Existing underground phones, if operational, may also be used to communicate with the fresh air base.

**NOTE TO TRAINER:** At this point, show the team the communication equipment they will be using. Demonstrate how to operate it.

## **Backup Communication**

At the fresh air base, there should be an attendant who is in charge of unwinding the communication line as you travel. This person, usually known as the line, or cable, attendant, also monitors the line to make sure it's not getting snagged or caught.

**Visual:** Refer again to Visual 5 as you discuss the signals. Use the visual as a PowerPoint, chalkboard sketch, or write the information on a chalkboard.

If the team loses voice contact with the fresh air base, it will be the attendant's job to receive and send signals to and from the team by a system of pulls or tugs on the communication line.

The signals are the same as those you use with a signal device:

One pull or tug:	Stop
Two:	Advance
Three:	Retreat
Four:	Emergency or Distress

If the team is stopped at one location for an extended period, or if it is performing a specific task, such as building a bulkhead or clearing a roadway, it's common practice for the fresh air base to signal one long pull about every five minutes to check on the team's condition. The team should then acknowledge that they are okay by returning the signal.

When you're using the cable to communicate with the fresh air base, the captain's signals to the team should also be relayed back to the fresh air base. The No. 5 person relays the captain's signals to the fresh air base by repeating them on the cable and then waits for the fresh air base to acknowledge that it has received the signal before sounding a response to the captain's signal. All this is done before the team executes the instructions dictated by the signal.

Actually, this is a lot less complicated than it sounds. Here's how it works: Say the captain wants to halt the team. He or she signals to stop the team. For the benefit of the fresh air base, the No. 5 person repeats the captain's signal by tugging once on the cable. The attendant at the fresh air base then acknowledges receiving the signal by sending it back to the team.

Once the No. 5 person received the fresh air base's acknowledgment, he or she then returns the signal to the captain. This means that (1) the No. 5 person has heard the captain's signal, (2) the signal has been relayed to the fresh air base, and (3) is acknowledged by a return signal. The team may then proceed to execute the command dictated by the signal.

Using the communication cable as a signaling device can present problems. For example, it becomes more difficult to signal with the cable if the team has advanced any great distance from the fresh air base. Also, when your team advances, the cable drags along behind you and has a tendency to get caught when the team goes around corners. Falls, debris, and other obstructions you may encounter after an explosion or fire may also snag the line and limit its use.

## Traveling Procedures

Most often, the team will be traveling on foot. But when transportation is available and conditions permit, transportation should be used. If locomotives are used, it's recommended that at least two be used in case one breaks down.

### Advancing and Tying In

As you advance within the affected area, it's recommended that you use the least obstructed travelway and stay on intake air whenever possible. In multi-level mines, the team explores level by level. Usually, the team explores the track drift first, and then, if miners are unaccounted for, the team will have to check the stopes.

In single-level, room-and-pillar mining it is a standard procedure to "tie in" as you advance. "Tying in" is the process by which you systematically explore all crosscuts and adjacent entries as you advance so that you are never forward of an unexplored area.

Until you've explored each entry and crosscut, you have no way of knowing what the conditions are in these areas. For example, there may be a fire located in an adjacent entry which could spread and cut off your escape. By tying in and ensuring that there is never any unexplored area between you and the fresh air base, you are protecting your own safety. Even though you know (or think you know) where survivors are located, or where a fire or explosion has originated, it's absolutely essential for you to tie in as you advance.

### Order of Travel

As your team advances underground, the captain always takes the lead, followed by the other team members. It's standard practice for the team captain to enter unexplored areas ahead of the rest of the team to check ground conditions. (It's even required in some states that no other team members enter an unexplored area ahead of the team captain.)

**Note:** Check your state law to determine whether it requires the captain to enter unexplored areas ahead of the team.

In most cases, the co-captain will be the No. 5 person. In this position, the co-captain can easily keep an eye on the other team members to make sure they're proceeding without difficulty. The co-captain can then quickly halt the team if anyone appears to be having trouble.

## **Rate of Travel**

The speed or rate at which you will travel underground is usually determined by the team captain. Your pace may change continually as you explore, reflecting changes in surrounding conditions that occur as the team advances. Your rate of travel will depend on a number of factors. Poor visibility or climbing up and down raises, for example, will slow you down, as will an obstructed or inclined travelway. You also won't be able to move as quickly if the team is carrying something, such as heavy equipment or an injured person.

The captain should regulate the team's pace according to the conditions encountered. Another thing to consider when the captain decides your rate of travel, is the condition of the team members themselves. If the team is on their way back to the fresh air base, or if they've been doing strenuous work, they will naturally be more tired. Again, the captain should adapt the rate of travel to take this into account.

## **Traveling in Smoke**

Traveling in smoke always presents difficulties for a mine rescue team. The biggest problem is the fact that you can't see where you're going as easily. The smoke may be light enough that it limits your visibility only slightly, like a light fog or mist. But it can also be so dense as to completely obscure everything around you.

Smoke so dense that it conceals the back and sides and other reference points you normally use to guide you from place to place can cause you to experience what's known as "spatial disorientation." When spatial disorientation occurs, you lose your sense of "which end is up," so to speak. You may bump into things and perhaps even completely lose your balance and fall down. For these reasons, it's recommended that when rescue teams travel in smoke, all team members should be linked together by means of a linkline or should hold onto the communication cable.

The captain can use a walking stick as an aid in checking the area in front of the team for bad ground and obstructions. There are also two methods commonly used to help you see a little better when you're traveling in smoke. One method is to remove your cap lamp from your cap and hold it at waist level.

Because your cap lamp is normally above eye level, it can produce glare in smoke. If you've ever tried to travel through dense fog with your car's high beams on, you know how difficult it is to see. You can see much better in fog with the low beams on because they produce less glare. So when you're traveling in smoke, you can improve your visibility by lowering the beam on your cap lamp and holding it at waist level.

Another way to improve your visibility in heavy smoke is to let the lamp hang from its cord to light up the rail or side that you're moving along. This technique helps you see a little easier because the smoke is usually less dense closer to the mine floor. Also, high-intensity lights can be used in some mines, and these are helpful in smoke.

If smoke is so dense as to make visibility very poor, you may need to keep in constant physical contact with a rail, a compressed air or water line, or the side in order to “feel” your way along.

### **Traveling Through Ventilation Controls**

As your team advances, you may find it necessary to determine conditions on the other side of doors, mandos, or bulkheads, or you may have to travel through them. This is normally done **only** on orders from the command center. Before going through a ventilation control, the team should first try to determine what conditions exist on the other side of it by feeling the bulkhead or door for heat and looking for smoke.

Before you open and travel through any bulkheads or doors beyond which conditions are not **definitely** known, you should first erect a temporary bulkhead outside it. Doing so provides an air lock which ensures that when the bulkhead or door is opened, you will not mix the atmospheres and alter the current status of the ventilation.

### **Traveling Through Water**

When your team encounters water during exploration, the command center will usually decide how to deal with the problem. The captain can probe the water depth with a walking stick, if necessary. If the water isn't too deep and you can get through it without endangering the team, you will probably just travel through it. It's recommended that you don't travel through water that is more than knee deep. If it's possible to detour the water by traveling an alternate route, that may be the best route to take.

There is still one other alternative to be considered. If you have pumping equipment, and gas conditions in the area permit pumping, your team may pump the water out. Keep in mind that it's extremely important to know the gas conditions at the site. The water itself may contain hazardous water-soluble gases which can be released into the “good” atmosphere as the pumping operation proceeds. Also, any air that's sucked into the line could carry hazardous gases.

In mines with explosive gases, the pump itself should be set up in an area with good air and have non-conducting suction lines leading to the water.

### **Crawling or Climbing**

As you advance, it may be necessary to crawl or to climb inclines or ladders. Keep in mind that this tires the team, so you should do it only when absolutely necessary.

## Marking Route of Travel

**Note:** Some mines use chemical lights or surveyor ribbon for marking routes.

As the team advances, your communication line trails along behind you, marking your route through the mine. Your captain or co-captain may also mark the team's route with chalk or spray paint at key points.

Here's how it's done: As you proceed, the captain or co-captain marks an arrow on the side at each intersection where your direction of travel changes. The head of this arrow points toward the fresh air base. As the team returns to the fresh air base, the captain or co-captain draws an "X" through each arrow to show that the team has retreated.

There are two reasons for marking your route of travel: (1) It helps the team find its way back to the fresh air base, and (2) If a backup team is sent in to look for you, it shows them which way you traveled.

**Note:** If a number of teams are going into the same area, this procedure for marking the team's route of travel may end up being more confusing, so it may not be a practical procedure to follow.

## Marking Areas Explored

As the team advances, the captain also marks areas explored by initialing and marking the date on crosscuts, impassable falls, barricades, bulkheads, air doors, and at other points where conditions don't permit the team to advance. All of these places should also be noted on the map. Marking areas as the team explores provides a visual record of what the Team did and found as they advanced.

## Ground Testing

As the team explores, the captain takes the lead, checking the ground conditions before the team advance into the area.

## Checking the Back and Sides

The team captain should constantly conduct visual inspections of the back and sides as the team advances unless, of course, smoke makes this impossible. In circumstances of good visibility where visual inspection indicates an unsafe area, a scaling bar can be used to check the condition of the back and sides, provided the back isn't too high.

If the team encounters bad ground conditions, they may have to scale loose material or support it before advancing under it. If space permits, the team can simply detour the hazardous area by walking to the right or left of it. It's standard practice to mark this hazardous area with chalk or some other type of marker, and note the location on the mine map. This makes the hazardous area easy to spot when the team retreats and also serves as a warning for other teams that may enter the area.

In heavy smoke conditions where visual inspection of the back and sides is impossible, you must watch the floor for fresh fallen material. The team captain can use a walking stick to probe the floor in front of the team if visibility is near zero. If you come to an area where the back or sides have fallen, you should, if possible, check the area with a scaling bar and scale down any loose material.

Advancing under bad conditions in heavy smoke can be dangerous because it is hard to see what the overall ground conditions are. In such situations, the command center will have to evaluate all the factors to determine what the team will do—whether they will detour the area, or support it and advance under it.

In addition to checking ground conditions routinely as the team advances, the captain should check the back in the area whenever the team builds an air lock or bulkhead, or erects a brattice line. Also, a check of the back should be made in the area before the team starts firefighting activities. This is very important to remember because the heat from the fire can greatly weaken the back. To protect yourselves as much as possible from weak back, you should test the back near a fire frequently and scale down any loose material.

## Testing for Gases

Monitoring the mine atmosphere for the presence of oxygen, explosive gases, and carbon monoxide is another important element of team exploration.

**NOTE TO TRAINER:** Depending on the type of mine and the specific situation, you may have to test for other gases. Mention others for which the team may be testing.

These tests should be made at each intersection and at your furthest point of travel into each passageway. It's also necessary to conduct gas tests on the other side of doors or bulkheads prior to traveling through any of them, especially where conditions on the other side are not definitely known. If you encounter smoke or potentially dangerous gas conditions, you will want to monitor gas levels frequently as you advance.

**Note:** For more detailed information on specific gases and when and how to test for them, refer to the *Mine Gases* module.



## Progress Reporting

Information the team relays to the fresh air base as it proceeds is known as the “progress report.” Progress reports keep the fresh air base up-to-date on what your team is doing, where you are, and what you’ve found. Once the coordinator at the fresh air base receives the progress report, the information is then relayed on to the command center. This information may then be used as a basis for making further rescue and recovery plans.

The progress report also helps keep track of your team so that if it becomes necessary to send a backup team in to find you, they’ll know where to look. Include information such as the team’s condition, the condition of each member’s apparatus, the team’s location, and their progress.

As you advance, report the condition of ventilation controls and auxiliary fans. If they are damaged, be specific as to what type of damage they’ve received and how extensive it is. Also, if doors or bulkheads are blown out, be sure to report in what direction they have blown, and report the position of compressed air and water line valves, open or closed. You should also report any other damage caused by fire, explosion, or other condition.

A progress report should also include information about ground conditions and gas conditions. Report any encounter with smoke or water. Report the location of tools, materials, and other equipment you encounter as you progress. When reporting power equipment, mention whether the switch is on or off. Report the condition of the track and the position of track switches.

Be sure to include the location of explosive magazines and storage areas for oil or oxygen and acetylene cylinders. Also, report the location and examine the contents of any dinner buckets you find, because these may offer important clues as to the whereabouts of survivors.

**NOTE TO TRAINER:** Miners are taught that if they become trapped in the mine, they should leave notes in their dinner buckets telling where they are. For this reason, the mine rescue team should search all dinner buckets they encounter during exploration.

If you locate survivors or bodies, report this immediately to the fresh air base. In your progress report, be sure to include any other significant conditions, materials, or evidence the team encounters during exploration. When you report anything to the fresh air base, be sure you clearly and correctly identify the location.

## Mapping

As the team advances, the map person records what the team encounters by marking the information on a mine map. At the same time, the fresh air base coordinator marks a mine map with your findings based on what you include in your progress report. The same information is then relayed on to the command center, where a third map is marked with the team's findings.

This "simultaneous mapping" provides the fresh air base and the command center with a visual record of what is happening underground. The maps are very important elements of mine rescue. Officials in charge on the surface use these maps as a basis for making decisions and providing the team with instructions.

**NOTE TO TRAINER:** Refer to Visual 6 for multi-level mines or Visual 7 for single-level, room-and-pillar mines as you explain what information should be marked on the map. Use these visuals as a PowerPoint, chalkboard sketch, or handout.

Here is the information you should mark on the mine map as the team explores:

1. Bad ground conditions
2. Water
3. Smoke
4. Gas readings
5. Valves on water and compressed air lines (open or closed)
6. Firefighting equipment
7. Other equipment and tools
8. Types and position of power equipment (on or off)
9. Storage areas for materials
10. Evidence of fire and/or explosion
11. Dinner buckets
12. Condition of ventilation controls
13. Survivors
14. Bodies
15. Any other significant conditions, materials, etc.

Before you actually explore a mine, take time to establish a uniform set of map symbols and learn to use them. Familiarize yourself, too, with the scale of the map you will be using.

The map person and the fresh air base coordinator should also practice together to perfect their method of simultaneous mapping.

**Review questions:** Ask team members the following questions and allow time for them to answer. Discuss the answers with them so they fully understand the material covered in this section.

1. What team signals do you use during exploration?

One—stop, two—advance, three—retreat, four—emergency)

2. List four factors that affect a team's rate of travel.

Falls and obstructions, water, smoke, fatigue, amount/weight of equipment carried, degree of slope

3. Describe how a team marks its route of travel on advance and retreat.

As you advance, the captain or co-captain draws or paints an arrow along the side at all intersections where your direction of travel changes. (The head of the arrow points toward the fresh air base.) On retreat, the captain or co-captain puts an "X" through each arrow.

4. List six findings that should be marked on a mine map.

Dinner buckets, bad ground conditions, water, smoke, storage areas, gas readings, valves on air and water lines, firefighting equipment, equipment and tools, power machinery, condition of ventilation controls, survivors, bodies, other significant conditions and materials.

## **Return to the Fresh Air Base**

It's very important for the team to pace its work so that it can return to the fresh air base on time. Also, you must be sure to allow an ample supply of oxygen for the return trip to the fresh air base plus an extra "margin of safety" in case anything unforeseen occurs.

Be sure to take into account the fact that you'll be more tired when returned to the fresh air base, so the return trip will usually take longer than the advance. You'll probably need to take longer and more frequent rest stops on the return trip. If you're carrying a survivor, this will tend to make the trip even slower.

The time a team spends underground is usually limited to two hours or less. The exact amount of time is determined both by the underground conditions and the type of apparatus being used. The distance you can advance also depends on underground conditions.

If your team is late getting back to the fresh air base and has stopped communicating, a backup team will be sent in to look for you, even if it means delaying the entire operation. So, if you're going to be late, be sure to communicate your intentions to the fresh air base. Under certain circumstances, even when you are working well within the time limits originally set, your captain may order the team to return immediately to the fresh air base, if, for example, a team member's apparatus malfunctions.

You may also be ordered to return immediately if you encounter gas conditions that present an imminent explosion hazard, a fire that you can't extinguish, or excessive water. Your captain may also order you to return to the fresh air base if you encounter bad ground that's impossible to detour and too hazardous to secure.

There are certain other conditions that won't necessarily require retreat but will hinder your team's progress. For example, encountering water in passageways will slow you down. Dense smoke is also a hindrance. Climbing a steep incline or ladder or crawling for a distance will slow you down also. The team may be permitted to advance under these conditions if it's definitely known that a life will be saved by the action and if you have the approval of the officials in charge of the operation.

## Debriefing

When you return to the fresh air base, your team captain will confer with the fresh air base coordinator and the captain of the incoming team to exchange information about what the team saw and found. At this time, the team captain and the coordinator should compare maps to make sure their markings correspond.

The information that your team captain should transfer to the backup team includes such things as the traveling conditions your team encountered, how far you traveled, what gases you encountered, and ground conditions.

If your team built bulkheads, your captain should explain what you constructed and what remains to be completed. Be specific about any equipment and supplies your team left in the area. Your team captain may also make suggestions as to what equipment the incoming team should take with them.

When you arrive on the surface, your team will attend a debriefing session. Like the briefing session, the debriefing session is set aside for information gathering. This time, however, your team **provides** the information. You inform the debriefing official or committee of what you did, saw, and found during exploration. Besides reviewing your team's findings you'll also review the team's map to make sure the markings on it correspond with the master map. During the debriefing session, you are also generally told what you should and should not say to media representatives and to others.

The debriefing session is a very important aspect of your team's exploration. Often, significant details that appeared to be unimportant while you were underground or were simply overlooked in your progress reports come out during this debriefing session and turn out to be important factors to the operation.

**Review questions:** Ask team members the following questions and allow time for them to answer. Discuss the answers with them so they fully understand the material covered in this section.

1. Under what conditions/situations might your team captain order your team to return to fresh air immediately?

Malfunctioning apparatus, hazardous ground that cannot be secured, presence of gases that produce an imminent explosion hazard, fire that cannot be extinguished, excessive water

2. What information is usually transferred from the outgoing team to the backup team at the fresh air base?

Markings on mine maps, damages, distance traveled, gas conditions, ground conditions, bulkheads constructed, equipment or supplies left in the area, and any other important information

3. Why is the debriefing session important?

It provides the officials in charge with more detailed information, ensures all important findings are mentioned, provides time to check team's map against master map, and instructs team as to what they should or should not say to media representatives and others.

**NOTE TO TRAINER:** Refer to the *Activity Book* for practice exercises related to exploration.

[This Page Intentionally Left Blank]

# **REQUIREMENTS FOR A FRESH AIR BASE**

1. Positive ventilation and fresh air
2. Travelway for people and supplies
3. Communication with Command Center
4. Communication with team

**Visual 1**

**Requirements for a Fresh Air Base**

[This Page Intentionally Left Blank]



## **COORDINATOR'S RESPONSIBILITIES**

- 1. Communication with team and command center**
- 2. Follow and mark team's progress on map**
- 3. Coordinate and oversee all activities**

**Visual 2**

**Fresh Air Base Coordinator's Responsibilities**

[This Page Intentionally Left Blank]

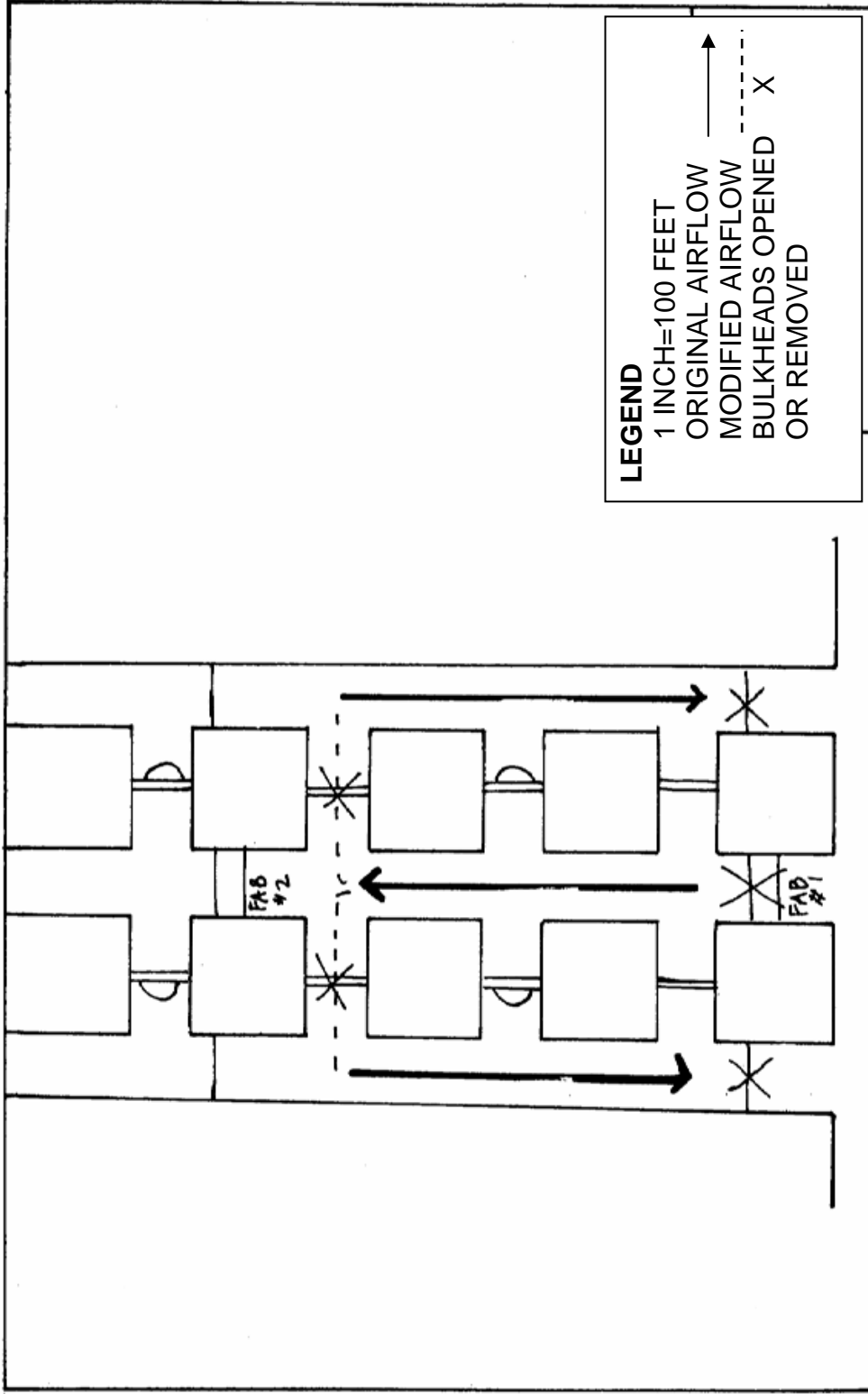

**Visual 3**

**Advancing the Fresh Air Base  
 Single-Level, Room-and-Pillar Mine**

[This Page Intentionally Left Blank]

## Visual 4

## Briefing Questions

1. Is the evacuation complete? Are any miners missing? If so, how many and what are their possible locations?
2. What is known about the cause of the disaster?
3. Is your team the first one to explore? (In multi-level mines, the team would also want to know if there are any other teams working on other levels.)
4. Have state and Federal officials been notified?
5. Have the shaft and hoist been checked? If so, what condition are they in?
6. Are guards stationed at all mine entrances?
7. Is the ventilation system operating? Is it an intake or exhaust system? Are attendants posted at the surface ventilation controls? Have air samples been taken? If so, what are results?
8. Will there be a backup team standing by at the fresh air base, and reserve teams on the surface?
9. What are the team's objectives, and what is their time limit?
10. What conditions are known to exist underground?
11. Is the mine's communication system operating? Is it being monitored?
12. Is power to the affected area on or off?
13. Is there diesel or battery-powered equipment or a charging station in the affected area?
14. What type of equipment is in the area? Where is it located?
15. Where are air and/or water lines located? Are they in operation? Are valves known to be open or closed?
16. What type of firefighting equipment is located underground? Where is it?
17. What tools and supplies are available underground? Where are they?
18. Are there storage areas for oil or oxygen, acetylene tanks, or explosives in the area to be explored?

**Handout**

[This Page Intentionally Left Blank]

# **MINE RESCUE TEAM SIGNALS**

**ONE-STOP**

**TWO-ADVANCE**

**THREE-RETREAT**

**FOUR-DISTRESS/EMERGENCY**

**Visual 5**

**Mine Rescue Team Signals**

[This Page Intentionally Left Blank]





[This Page Intentionally Left Blank]

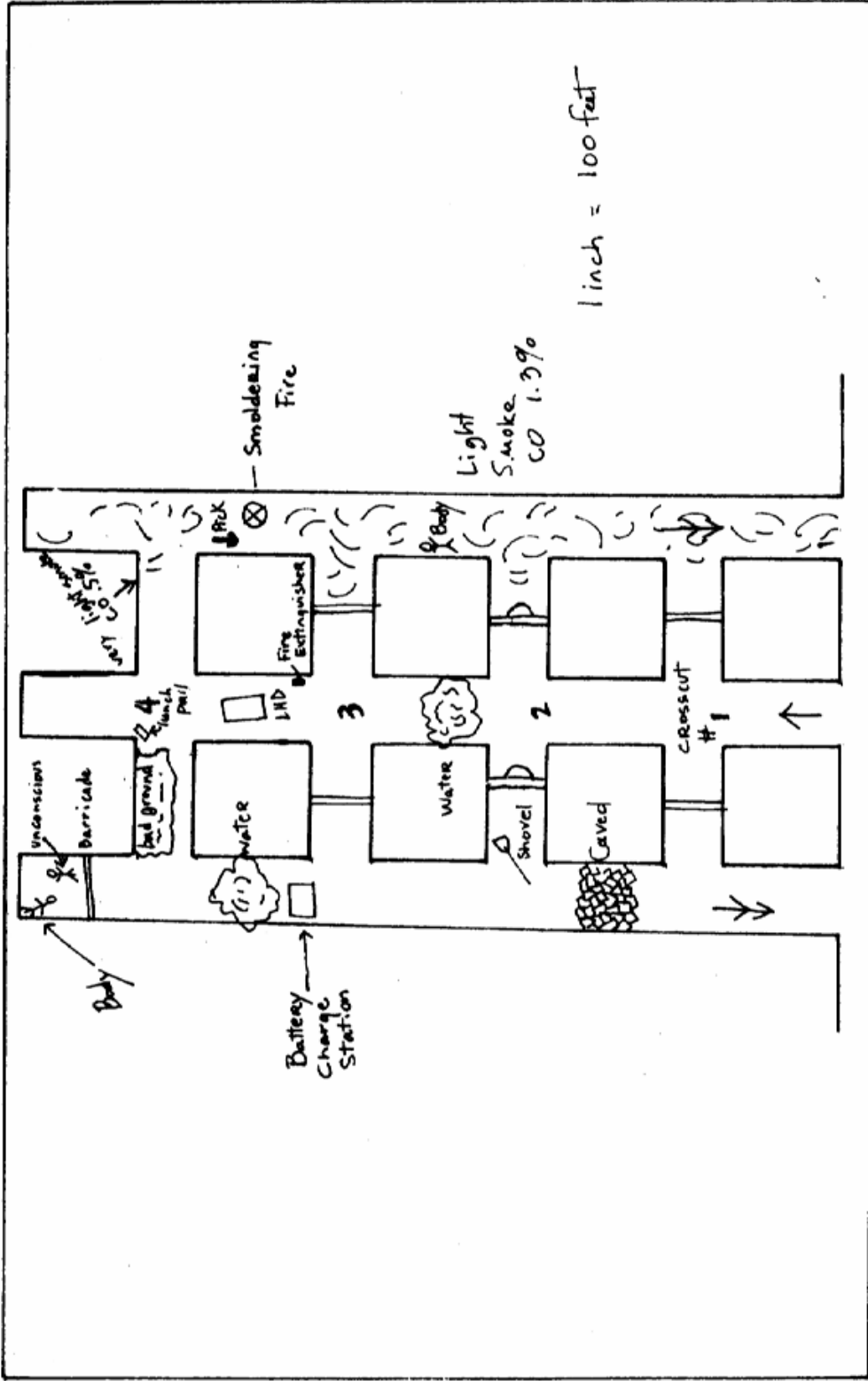

Visual 7

Marking the Mine Map  
Single-Level, Room-and-Pillar Mine

[This Page Intentionally Left Blank]

## General Review Exploration

Have the team members choose the correct answer for each of these questions.

1. Prior to rescue team exploration, the first step to take after a disaster is to:
  - a. Examine all mine openings.
  - b. Establish a fresh air base.
  - c. Proceed as far as possible into the mine without apparatus.
  - d. None of the above.
2. The purpose of rescue team exploration is to:
  - a. Determine conditions underground.
  - b. Locate missing miners.
  - c. Locate clues or indications of missing miners' locations.
  - d. All of the above.
3. If at all possible, entry into the mine should be made on:
  - a. An exhaust airway.
  - b. An intake airway.
  - c. The main haulageway.
  - d. The belt entry.
4. Barefaced exploration should be attempted only when:
  - a. No breathing apparatus is available.
  - b. Miners are trapped in the mine.
  - c. A backup mine rescue team with apparatus is immediately available.
  - d. A fresh air base is established.
5. In advancing a fresh air base, after you put up the new air lock, the team should:
  - a. Come out of the mine.
  - b. Perform gas tests in all dead ends and high places between the old and new fresh air base to ensure that all gases have been flushed from the area.
  - c. Proceed beyond the new fresh air base to explore and let other workers check for any gases in the area between the old and new fresh air bases.
  - d. Shut off and remove your apparatus since you are in fresh air and will no longer need it.

6. When exploring in heavy smoke, it is recommended that the team:
  - a. Use a linkline to hook all team members together.
  - b. Follow along the rail to aid their progress.
  - c. Keep in contact with the side to aid their progress.
  - d. All of the above are recommended.
  
7. Prior to a mine rescue team passing through a door or bulkhead behind which conditions are not definitely known, they should:
  - a. Ask the fresh air base to send in the backup team.
  - b. Erect an air lock to prevent the mixing of atmospheres.
  - c. Open the door or bulkhead and wait at least 10 minutes so that any harmful gases are diffused.
  - d. Never enter such areas.
  
8. Gas readings should be taken:
  - a. At all intersections.
  - b. At any dead end.
  - c. At the furthest point of travel in any passageway.
  - d. All of the above.
  
9. The captain should mark the date and his or her initials:
  - a. Each time the team stops for a rest.
  - b. Every 50 feet.
  - c. Every 200 feet.
  - d. On all explored areas (crosscuts, impassable falls, barricades, bulkheads, air doors, etc.)
  
10. Dinner buckets encountered during exploration are important because:
  - a. They can contain food and/or water for the rescue team.
  - b. They may contain notes that would indicate the whereabouts of survivors.
  - c. They indicate where miners ate their dinner.
  - d. None of the above.
  
11. If a team member experiences problems with his or her apparatus beyond the fresh air base, the team member should:
  - a. Be immediately sent back to the fresh air base.
  - b. Be sent back to the fresh air base with another team member.
  - c. Switch to the apparatus that was carried on the stokes basket or stretcher.
  - d. With the entire team, return immediately to the fresh air base.

12. Debriefings are held to:

- a. Inform news reporters of developments.
- b. Inform family members of developments.
- c. Review the rescue team's findings after they have returned from underground.
- d. All of the above.

General review answers:

1. a
2. d
3. b
4. c
5. b
6. d
7. b
8. d
9. d
10. b
11. d
12. c



## Glossary

**Air lock** – An area in the mine closed at both ends by doors, or by bulkheads with flaps or doors in them. Used to prevent mixing of different atmospheres while still permitting miners to enter and exit.

**Backup team** – Rescue team stationed at the fresh air base as a “backup” for the working team beyond the fresh air base.

**Briefing** – Session held before a team goes underground to inform team members of conditions underground and give them their work assignment.

**Debriefing** – Session held when a team returns to the surface after completing an assignment to review what they saw and did.

**Fresh air base** – Base of operations from which the rescue and recovery teams can advance into irrespirable atmospheres.

**Linkline** – Line that links team members together. Used in smoke, it is usually a rope about five feet long with rings for each team member to hook onto.

**Progress reporting** – Information the team relays to the fresh air base as it proceeds.

**Standby team** – Team scheduled to be on the surface in ready reserve when rescue teams are working underground.

**Tying in** – Systematic exploration of all crosscuts and adjacent entries in a single-level, room-and-pillar mine so that the team is never forward of an unexplored area.

[This Page Intentionally Left Blank]

**A Guide to  
Mine Rescue Training –  
Metal and Nonmetal**

**Fires, Firefighting, and  
Explosions**

**Module 5**

# Table of Contents

Course Objectives .....	5-1
Course Materials .....	5-1
Course Outline .....	5-2
Instructor Notes and Suggested Lecture .....	5-4
Visuals.....	5-29
General Review.....	5-47
Glossary .....	5-50

# Course Objectives

## Main Objective

The mine rescue team will be able to competently assess underground conditions during a mine fire and after an explosion, and be able to properly fight a fire.

## Supportive Objectives

The team members will:

- Identify the components and meaning of the fire triangle.
- Identify the equipment used in firefighting.
- Identify the proper procedures for locating and assessing a mine fire.
- Identify and demonstrate the proper techniques for fighting a fire directly.
- Identify and demonstrate the proper techniques for sealing a mine fire.
- Identify the causes and effects of explosions.
- Identify and demonstrate the proper procedures for assessing conditions following an explosion.

## Course Materials

Required:

- Handouts and visuals from the back of this module
- Pencil and paper for each team member
- Mine Rescue Activity Book

Suggested:

- Any firefighting equipment that the team will be using, or pictures or slides of the equipment if it is not available
- Laptop computer
- PowerPoint program
- Chalkboard or flipchart

# Course Outline

- I. Introduction
- II. Fires
  - A. Fire triangle
  - B. Classification of
- III. Firefighting equipment
  - A. Dry chemical extinguishers
    - 1. General information
    - 2. How to use hand-held extinguishers
    - 3. Using hand-held extinguishers on an obstacle fire
    - 4. How to use wheeled extinguishers
  - B. Water
    - 1. Waterlines
    - 2. Fire cars
    - 3. Fire cars with low expansion foam
    - 4. Techniques of applying water to fires
  - C. High expansion foam
    - 1. Description
    - 2. Foam generators
      - a. Description
      - b. How to use
- IV. Firefighting
  - A. Before going underground
  - B. Locating fires and assessing conditions
  - C. Direct firefighting
    - 1. General procedures
    - 2. Hazards of
      - a. Electrocutation
      - b. Toxic and asphyxiating gases
      - c. Oxygen deficiency
      - d. Explosive gases
      - e. Heat, smoke, and steam

## D. Indirect firefighting

### 1. Sealing underground

- a. Planning
- b. Temporary seals

#### (1) Types of

- (a) Brattice cloth
- (b) Concrete block
- (c) Wood

#### (2) Considerations while building temporary seals

- (a) Air sampling tubes
- (b) Ventilation
- (c) Explosions
- (d) Isolation

### c. Permanent seals

#### (1) Types of permanent seals

#### (2) Considerations while building permanent seals

- (a) Isolation
- (b) Air sampling tubes

### d. Taking air samples

### 2. Foaming the fire area

- 3. Using sandfill
- 4. Flooding the mine

## V. Explosions

### A. Causes and effects

### B. Before going underground

### C. Exploration: Indications of explosion and assessment of conditions

# Instructor Notes and Suggested Lecture

## Introduction

**Note:** Because of the large diversity of minerals and ores mined in metal/non-metal mines and the diversity of mining techniques used, terminology will vary somewhat from operation to operation. Consequently, the mining terminology used in this training module may or may not agree completely with the terms used in your area. It may be necessary, therefore, for you to adapt and change some of the terminology to suit the needs of the team. For example, in some mines, the term “back” (used throughout this module) will have to be changed to “roof.”

Fighting a mine fire may be one of the most frequent duties that you perform as a rescue team. Fires in underground mines are particularly hazardous not only because they produce toxic gases and heat, but also because they produce smoke, pose an explosion hazard, and create oxygen-deficient atmospheres.

In this module we will talk about fires and explosions in the mine—how they occur and how they affect your job as a mine rescue team.

Most fires are the result of a chemical reaction between a fuel and the oxygen in the air. Material such as wood, gas, oil, grease, and many plastics will burn when ignited in the presence of air. In each case, three elements are needed at the same time for the fire to occur: **fuel**, **oxygen**, and **heat** (which are initially provided by the ignition source).

**NOTE TO TRAINER:** As you discuss the following information, refer to Visual 1 for an illustration of the fire triangle. Use this visual as a PowerPoint, chalkboard sketch, or handout.

The “fire triangle” can be used to illustrate the three elements necessary for fire. Each leg of the triangle is labeled with one of the elements: fuel, oxygen, or heat. If one element is missing to begin with, the fire will not start.

Therefore, to **extinguish** a fire, it is necessary to **remove** one element, or one leg of the triangle. Removing one element from the fire is, in fact, the principle that underlies almost all firefighting methods.

Fighting a fire with water removes the heat. Smothering the fire with noncombustible materials removes the oxygen. Sealing off the fire area is another way of removing oxygen. Loading out hot materials from the fire area removes the fuel. Another way to extinguish a fire is by stopping the chemical reaction between the fuel and the oxygen. Dry chemical extinguishers operate on this principle. They function to chemically inhibit the oxidation of the fuel.



Exactly how a fire will be fought is usually determined by the materials that are burning and the conditions in the fire area. Consequently, **a large part of your job will be to explore the mine and assess the condition of the fire so that the Command Center can decide how to go about fighting the fire.**

## Classification of Fires

**NOTE TO TRAINER:** Refer to Visual 2 for a chart showing the following four classes of fires. Use this visual as a PowerPoint, chalkboard sketch, or handout.

For firefighting purposes you should know the type of fire you are fighting. The National Fire Protection Association classifies fires into the following four classes:

**Class A** fires involve ordinary combustible materials such as wood, plastics, paper, and cloth. They are best extinguished by cooling with water or by blanketing with certain dry chemicals.

Think of Class A fires as those that leave **A**shes.

**Class B** fires involve flammable or combustible liquids such as gasoline, diesel fuel, kerosene, and grease. Typical Class B fires can occur where flammable liquids are spilled or leak out of mechanical equipment. They are best extinguished by excluding air or by special chemicals that affect the burning reactions.

Think of Class B fires as those that involve contents that will **B**oil.

**Class C** fires are electrical fires. Typical electrical fires include electric motors, trolley wire, battery equipment, battery-charging stations, transformers, and circuit breakers. They are best extinguished by non-conducting agents such as carbon dioxide and certain dry chemicals.

If the power has been cut off to the burning equipment, the fire can be treated as a Class A or B fire.

Think of Class C fires as those that involve **C**urrent.

**Class D** fires involve combustible metals such as magnesium, titanium, zirconium, sodium, and potassium. Special techniques and extinguishers have been developed to put out these fires. Normal extinguishers generally should not be used on a Class D fire since they could make the fire worse. Class D fires are not frequently found in mines.

# Firefighting Equipment

Mines usually have a number of different types of equipment available for firefighting:

- Dry chemical extinguishers
- Water
- High expansion foam

**NOTE TO TRAINER:** If the team uses other equipment, be sure to discuss that equipment also. The *Activity Book* that is provided with this training package includes various activities for using firefighting equipment. You may wish to use these activities end of the *Firefighting Equipment* module.

## Dry Chemical Extinguishers

Dry chemical extinguishers put out fires by stopping the chemical reaction between the fuel and oxygen (which produces the flame). The dry chemical agents work to inactivate the intermediate products of the flame reaction, which results in a decreased combustion rate (rate of heat evolution) and thus extinguishes the fire.

There are basically two sizes of dry chemical extinguishers: hand-held extinguishers and larger wheeled extinguishers. Hand-held extinguishers range in size from about 2 to 55 pounds. Wheeled extinguishers can weigh from 75 to 350 pounds. These extinguishers consist of a large nitrogen cylinder, a dry chemical chamber, and a hose with an operating valve at the nozzle.

It is generally recommended that mine rescue teams use multi-purpose dry chemical extinguishers, which contain monoammonium phosphate, because they are effective on Class A, B, or C fires. Consequently, having monoammonium phosphate extinguishers eliminates the team's need for a separate extinguisher for each class of fire that may be encountered underground.

## Hand-Held Extinguishers

**NOTE TO TRAINER:** Refer to Visual 3 for an illustration showing the proper way to use a hand-held extinguisher. Use this visual as a PowerPoint, chalkboard sketch, or hand-out.

**Before using any type of hand-held extinguisher, check the label** on the side of the extinguisher to make sure you're using the right extinguisher for the fire you'll be fighting. Using the wrong type of extinguisher could result in a spreading fire rather than an extinguished fire.

Most small dry chemical extinguishers are effective 5 to 8 feet from the fire. Larger units have ranges of 5 to 20 feet from the fire. Using an extinguisher that is effective for only 5 to 8 feet (while standing 10 to 15 feet away from the fire) will not put out the fire and may waste both valuable time and the contents of the extinguisher.

To operate a hand-held extinguisher, you should grasp it firmly and approach the fire from the intake air side, holding the nozzle downward at a 45-degree angle. You should stay low to avoid any rollback of the flames and try to get within 6 to 8 feet of the fire before turning on the fire extinguisher.

To effectively and quickly put out the fire, you should direct the stream of dry chemical to about 6 inches ahead of the flame edge. You should begin far enough away to allow the discharge stream to fan out and you should use a deliberate side-to-side motion as you cover the fire with the dry chemical. Each sweep of the chemical should be slightly wider than the near edge of the fire.

As you put out the fire closest to you, you should advance slowly toward the fire, forcing it back. You should always be on the alert for possible re-ignition of the fire even though it appears to have been extinguished. The discharge time of hand-held extinguishers varies from 8 to 60 seconds, depending on the size and type of fire extinguisher. A 30-pound extinguisher will normally last 18 to 25 seconds.

As a safeguard, be sure to maintain control of the extinguisher. If you lose control of the extinguisher, you could end up exposing other people to the dry chemical stream.

**NOTE TO TRAINER:** At this point you may want to discuss on the type of hand-held extinguisher the team uses. Follow manufacturer's recommendations.

## Using Extinguishers on an Obstacle Fire

If you encounter an obstacle fire with flaming equipment at its center, the fire should be fought by two people using hand-held extinguishers. It is difficult and sometimes impossible for one person to put out this type of fire.

The two firefighters should approach the fire together from the intake air side, holding the extinguisher nozzle downward at a 45-degree angle. Both streams of dry chemical should be directed to 6 inches ahead of the flame edge. The two firefighters should split up and slowly advance around each side of the obstacle, trying to keep up with each other as much as possible. Each person should cover two-thirds of the fire area, using a side-to-side sweeping motion. When the fire appears to be extinguished, both firefighters should remain on the alert for a short time just in case the fire re-ignites.

## How to Use Wheeled Extinguishers

To operate the wheeled extinguisher, you must first open the valve on the nitrogen cylinder. This forces the dry chemical through the hose to the nozzle. You then control the discharge from the hose by adjusting the nozzle operating valve.

The method for approaching the fire and putting it out is the same as the method used with the hand-held extinguisher. You should use a sweeping motion and direct the dry chemical stream to about 6 inches ahead of the flame edge.

**NOTE TO TRAINER:** At this point you may want to discuss on the type of wheeled extinguisher the team uses. Follow manufacturer's recommendations.

## Water

Water can also be used to put out fires. Water acts to cool the fire, removing heat from the fire triangle. Water is an effective extinguishing agent on Class A fires. In most mines, the water needed to fight underground fires can be provided by two sources: waterlines and fire cars.

## Techniques of Applying Water to Fires

The best way to fight a fire with water is to aim the water stream directly at the burning material. You should use a side-to-side sweeping motion to wet the entire burning surface. Where possible, you should break apart and soak any deep-seated fires and stand by to extinguish any remaining embers.

Several different kinds of water nozzles are available for the hose. Some produce a solid stream of water, some produce a fog spray, and others are adjustable, much like a garden hose nozzle, to produce a solid stream or a spray. Solid stream nozzles are best to use when it is necessary to project the water a long distance to the fire. For shorter distances, a fog spray is better to use on a fire because it usually will extinguish a fire more quickly than a solid stream.

## Waterlines

Waterlines are used in most mines and are available for firefighting purposes. In mines with shaft stations, waterline outlets located at the stations are required to have at least one fitting located for, and capable of, immediate connection to firefighting equipment. If you are going to fight a Class A fire, and a waterline is available, you can simply hook up the fire hose to the waterline.

## Fire Cars

**NOTE TO TRAINER:** Refer to Visual 4 for an illustration of a fire car. Use this visual as a PowerPoint, chalkboard sketch, or handout.

Fire cars (or water cars or chemical cars) are available in some mines. These may be mounted on tires or flanged wheels and can be pushed or pulled to the fire area. The components of a fire car can vary from a water tank, pump, and hose to a more elaborate version that contains a wider selection of firefighting equipment such as water, large chemical extinguishers, hand tools, and brattice cloth.

Some fire cars contain a foam agent that can be hooked up to the water hose along with a special foam nozzle to produce low expansion foam. The foam works to extinguish the fire by simultaneously smothering and cooling it.

Low expansion foam is very wet and heavy. It does not move down a passageway as high expansion foam would. Low expansion foam can only be used when you're close enough to a fire to force the foam directly onto the fire.

## Foam Generators

**NOTE TO TRAINER:** Refer to Visual 5 for an illustration of a foam generator or discuss and/or demonstrate the foam generator the team may use. There are many different models of foam generators and each model has its own method of operation. This section on using a foam generator supplies general information only. *If you wish to include more specific information on how to operate the model(s) that the team will be using, refer to the manufacturer's information.*

The high expansion foam is made by mixing water, air, and a foam concentrate or detergent in a foam generator. Foam generators are portable and come in different sizes with different foam-producing capacities. The smaller models may be hand-carried by two people or wheeled into position. Larger models may be mounted on rubber tires or may be transported on a track-mounted mine car.

There are water-driven models of foam generators and electric- or diesel-powered models. In the water-driven models, the foam is produced as the water/detergent mixture is pushed by water pressure through nylon netting or a screen. With the other models, a blower fan is used to produce the bubbles and push them out.

## How to Use a Foam Generator

There are a couple different methods of using foam to fight a fire. With one method, the foam generator is positioned near the fire, and plastic tubing is attached to the foam outlet. The plastic tubing is designed to unroll as the foam passes through it, leading the foam directly to the fire area. Another method is to first create a confined area so that the foam can be pumped onto the fire to completely fill or plug the fire area. This is done by building a bulkhead with an opening in it for the foam generator to fit into.

The foam generator is then set up at the opening and braced or fastened down if possible. Once it is set up, the generator can be started and foam will begin filling the area. Sometimes plastic tubing is attached to the foam generator to direct the foam to the fire area.

In some situations, a team can use the generator in stages, moving it closer to the fire as the fire is brought under control. Before you travel through a foam-filled area, you should knock down the foam with water to clear a path for you to safely walk along.

## High Expansion Foam

High expansion foam is used mainly to contain and control fire by removing two legs of the fire triangle—oxygen and heat. The tremendous volume of the foam acts to smother and cool the fire at the same time. Foam is useful only in fighting Class A or B fires. Because the foam is light and resilient it can travel long distances to a fire without breaking down.

Consequently, it is very effective and used most commonly in controlling stubborn localized fires that cannot be approached at a close range because there is too much heat or smoke or the fire is spreading too rapidly. When using foam, firefighters can be quite a distance from the actual fire. Five hundred feet is a common distance, although there have been successes in the past where foam was used from more than 1,500 feet away from the fire.

High expansion foam is normally used just to control a fire. Once conditions permit, teams are usually sent in to fight the fire more directly. It is generally recommended that teams do not travel through foam-filled areas. Consequently, before entering such an area teams should clear the foam as much as possible. One way of doing this is to use a solid stream of water to knock the foam down and clear the area.

**Warning:** Some foam generator manufacturers recommend that personnel should not travel through foam because hearing becomes difficult, vision is blocked, and breathing becomes uncomfortable. Also, there is the added hazard of slipping and falling in the foam. Some manufacturers also recommend that personnel do not wear self-contained breathing apparatus, gas masks, or other breathing apparatus into the foam.

However, if a team *must* travel through foam, it is essential that the team members use a linkline to ensure that no one gets lost in the foam. It is important that the team travel along the track or side, where the best footing is most likely to be.

**NOTE TO TRAINER:** If you have not done so already, refer now to the Activity Book for various activities on how to use the different types of firefighting equipment.

**Review questions:** Ask the team members the following questions and allow time for them to answer. Discuss the correct answers with the team so they fully understand the material covered in this section.

1. Discuss the characteristics of the four classes of fires and what extinguishing agents should be used when fighting each of them.
  - Class A fires are those that involve ordinary combustible materials such as wood, plastics, paper, and cloth. They are best extinguished by cooling with water or by blanketing with certain dry chemicals.
  - Class B fires are those that involve flammable or combustible liquids such as gasoline, diesel fuel, kerosene, and grease. They are best extinguished by excluding air or by special chemicals that affect the burning reactions.
  - Class C fires are electrical fires. They are extinguished by non-conducting extinguishing agents such as carbon dioxide and certain dry chemicals.
  - Class D fires are those that involve combustible metals such as magnesium, titanium, zirconium, sodium, and potassium. They are extinguished by special extinguishing agents designed for such applications.
  
2. Discuss each piece of equipment normally available to fight underground fires at the team's mine.
  - Hand-held extinguishers – type, location, how to operate the particular brand the team uses.
  - Wheeled extinguishers – type, location, how to operate
  - Fire cars – location, what equipment is on car, how to operate
  - Waterlines – hose location, how to operate
  - Foam generator – location, how to operate
  - Any other equipment the team uses

## Firefighting

When a team goes into a mine to explore or fight a fire, it should be concerned with two main things—spreading of the fire and the possibility of an explosion. Before going underground, the team should make sure that the **main fan is running**, that **a guard is monitoring the operation of the fan**, and that **tests are being made at the main exhausts** for any gases that may be present in the mine.

It is important to monitor the levels of oxygen and carbon monoxide and of any explosive gases. Ventilation should always be continued through the mine during a fire in order to carry explosive gases and distillates away from the fire area and to direct the smoke, heat, and flames away from the team.

**NOTE TO TRAINER:** You may want to remind the team that no sudden changes should ever be made to the ventilation. If the main fan is off or destroyed, the Command Center will have to make careful plans before starting the fan. Everyone should be out of the mine before the fan is started.

### Before Going Underground

Before going underground, the team should also know about any possible **ignition sources** that may exist in the affected area, such as battery-operated or diesel equipment. Also, if there are any underground **storage areas for explosives, oil and grease, or oxygen or acetylene cylinders** in or near the affected area, you should know about them.

If there is electrical power to the affected area of the mine, it is usually recommended that it be cut off. Arcing from damaged cables is a possible ignition source for further fires or explosions. However, if the power is cut, the mine will lose power to any auxiliary fans or booster fans underground.

You will also lose power to any other electrically powered equipment, such as a pump, in the area. Losing a pump could result in major flooding. These are all factors that the Command Center will have to consider when deciding whether or not to cut the power.

Most of this information should be available to the team at the time of your briefing. However, some of the very specific information about what is in or near the affected area and whether equipment has been left energized can only be determined by the exploration teams as they advance.



## Locating Fires and Assessing Conditions

Two of the main objectives of exploration work during a mine fire are **locating the fire** and **assessing the conditions** in and near the fire area. Once the conditions are known and reported to the Command Center, the officials there can then decide how the fire should be fought. The Command Center will want to have as much information as possible about the fire: where it is, what's burning, how large it is, and what the conditions are near the fire area.

Before you enter the mine, there might already be some information about where the fire is located. The first report of a fire will often have been from miners working near the fire area. They may have reported seeing smoke and/or flames before evacuating the mine. These reports will help you to pinpoint the location of the fire and may help to determine the magnitude of the fire. Carbon monoxide and/or smoke coming from the main fan or main exhaust are obvious indications that a fire exists.

Lab analysis of air samples from the main fan or exhaust will give an accurate analysis of the gases that are present and help provide information on what is burning. The amount of carbon monoxide found in the sample gives some indication of the magnitude of the fire.

**There is some information, however, that can only be obtained by rescue teams during exploration of the mine.** The teams can roughly pinpoint an unlocated fire and assess its magnitude by reporting where and how heavy the smoke is and by feeling bulkheads and doors for heat. If you encounter a small fire while exploring the mine, you should be able to extinguish it immediately by using hand-held fire extinguishers or water from a waterline if it is nearby. Dealing with larger fires, however, will require more equipment and careful planning.

During your exploration of the mine, you must gather as much information as possible about the conditions in or near the fire area. As the information is gathered, report it to the Command Center as soon as possible in order to keep the officials up-to-date with what you have observed.

You must take gas readings in the exhausts near the fire area to determine if the mine atmosphere is potentially explosive. Also, some damage to ventilation controls should be expected during a fire so you'll have to be especially aware of their condition. Check the ground conditions carefully in the fire area because heat from a fire can weaken the back and sides.

From all this information, the Command Center will have a fairly good indication of where and how large the fire is. Officials will then be able to decide how to go about controlling or extinguishing the fire—whether to fight it directly or indirectly by sealing the mine.

## Direct Firefighting

Fighting a fire “directly” means that an extinguishing agent is put directly onto the fire to put it out. This usually means that the firefighters will have to get relatively close to the fire in order to use fire extinguishers, water, or foam on the fire. When fighting a fire directly, you should always approach the fire and fight it from the intake air side, if possible. This will ensure that the smoke and heat will be directed away from you.

**Visual:** Refer to Visual 6 for an illustration of how to use a transverse brattice as you discuss it in the following section. Use this visual as a PowerPoint, chalkboard sketch, or handout.

If the fire begins to back up against the intake air in search of oxygen, you can put up a “transverse” brattice (or hurdle brattice) from side to side leaving an open space at the top. This will cause increased air flow at the back and should slow down the progress of smoke and flame into the intake air current. The brattice should cover about one-half to two-thirds of the area from the floor to the back. You don’t want to run the brattice too high or it will cut off airflow over the fire which could result in an explosion.

If heat, smoke, and ventilating air currents permit, water is the most desirable and efficient means of fighting a fire, provided it is not an electrical fire. Of course, to fight a fire with water there must be a sufficient supply of water, sufficient water pressure, and available lengths of hose to reach the fire. In situations where it is impossible to approach the fire for direct firefighting, foam or water can be pushed over the fire area to slow down the fire sufficiently, allowing the team to get closer to the fire to fight it more directly.

### Hazards of Direct Firefighting

**NOTE TO TRAINER:** Refer to Visual 7 for a list of the hazards of direct firefighting as you discuss the following section. Use this visual as a PowerPoint, chalkboard sketch, or handout.

During direct firefighting, there are certain hazards to the team in which you should be aware. These hazards include electrocution, toxic and asphyxiating gases, oxygen deficiency, explosive gases, and heat, smoke, and steam.

### Electric Shock and Electrocution

Electric shock and electrocution are hazards to firefighters using water, foam, or other conductive agent to fight a fire. For this reason, it is usually recommended that the power to the fire area be cut off regardless of the type of fire. This is done not only to eliminate the electrical hazard, but also to cut the power to any electrical components that may be involved in the fire.

## Toxic and Asphyxiating Gases

**NOTE TO TRAINER:** Refer to Visual 8 for a list of toxic gases produced from certain burning materials as you discuss them below. Use this visual as a PowerPoint, chalkboard sketch, or handout.

The extremely toxic gas, carbon monoxide, is produced by all fires because of the incomplete combustion of carbon materials during the burning process.

Carbon dioxide is also produced by fires, though it is a product of **complete** combustion. Carbon dioxide is an asphyxiate. Breathing large amounts of carbon dioxide causes rapid breathing and insufficient intake of oxygen. Too much of it in the bloodstream can cause unconsciousness and even death.

Other gases such as hydrogen sulfide are even more toxic than carbon monoxide. Some toxic gases are produced by burning rubber, neoprene, or polyvinyl chloride (PVC). These materials are frequently found in electrical cables, conveyor belts, or tires on machinery. Even small fires that involve burning rubber, neoprene, or PVC can be extremely toxic.

Because all of these gases can harm you, it is extremely important that you wear your breathing apparatus at all times when dealing with underground fires.

## Oxygen Deficiency

**NOTE TO TRAINER:** Refer back to Visual 7 for the list of hazards of direct firefighting. Use this visual a PowerPoint, chalkboard sketch, or handout.

Because fire consumes such large quantities of oxygen, there is a hazard of oxygen deficiency in the mine—another reason for you to wear your breathing apparatus when dealing with mine fires.

## Explosive Gases

The buildup of explosive gases, such as hydrogen and methane, are very real hazards for teams during direct firefighting. That is why it is so important to maintain a sufficient and consistent flow of air over the fire area.

Methane is a highly explosive gas. Its explosive range is 5 to 15 percent when there is at least 12.1 percent oxygen present.

Hydrogen is also highly explosive in mine atmospheres. Its explosive range is 4.0 to 74.2 percent when there is at least 5 percent oxygen present. Hydrogen is produced by the incomplete combustion of carbon materials during fires. Additionally, hydrogen can be liberated when water or steam comes in contact with hot carbon materials. This situation occurs when water, water mist, or foam is used to fight fires.

Small hydrogen explosions, known as hydrogen “pops,” are fairly common in fire-fighting. The bigger hazard with hydrogen is the possibility of it accumulating to a large enough extent to cause a violent explosion. Adequate ventilation over the fire area will help prevent the buildup of these and other explosive gases. If the fan slows down or stops, teams should immediately leave the fire area. If the fan continues to run slowly or remains stopped, teams and other underground personnel should leave the mine entirely before the fan is restarted.

**The fan should never be stopped or reversed while teams are underground.** This could force unburned distillates from the fire to travel back over the fire area, thereby increasing the magnitude of the fire. **If any explosive concentrations of gas are detected in the exhaust air of the fire, all teams and any other underground personnel should leave the mine immediately.**

## **Heat, Smoke, and Steam**

Heat, smoke, and steam are other hazards to the team and will determine how close you can get to a fire and how long you can work. Working in a hot, smoky, or steamy atmosphere can be extremely uncomfortable.

Smoke not only limits your visibility but it also causes disorientation. Even the simple act of walking is more difficult because you will not be able to judge your position in relation to your surroundings as you normally do when moving. This lack of orientation may cause you to lose your sense of balance more frequently. Working in a hot and/or steamy atmosphere will tend to make you more exhausted than normal and cause additional stress on your system, especially if you’re working hard.

Another hazard of heat is that it tends to weaken the back in the fire area. You should, therefore, check the ground conditions near a fire area frequently and scale any loose material. Be cautioned, also, that cold water applied to hot rock can cause explosive fragmentation of the rock. Smoke and steam will be less dense near the floor of the mine and worse near the back of the mine. Adequate ventilation over the fire area should help to carry the smoke, heat, and steam away from the team.

However, if the fire begins to back up against the flow of intake air in search of oxygen, you can put up a transverse brattice from side to side, leaving an open space near the back. This should slow down the progress of the smoke and flame into the intake air current.

## Indirect Firefighting

Sometimes fighting a fire directly is ineffective or not possible because of certain hazards such as high temperatures, bad ground, or explosive gases. In these cases, it may be necessary to fight the fire from a distance, or “indirectly,” by sealing the fire or by filling the fire area with foam, sandfill, or water. The indirect methods work by excluding oxygen from the fire. The foam or flood of water also serves to cool the fire.

These indirect methods also help the firefighters to remain a safe distance from the fire while they work to control and fight a large or otherwise unapproachable fire.

**Review questions:** Ask the team members the following questions and allow time for them to answer. Discuss the answers with them so they fully understand the material covered in the previous section.

1. Discuss why the fan should be kept running during underground firefighting.
  - a. To ensure that explosive gases and distillates are carried away from the fire area. This lessens the chance for an explosion to occur.
  - b. To direct smoke, heat, and flames away from the team.
2. Discuss a method of controlling the backup of a fire against the ventilating current (intake air) while fighting it directly.

A transverse brattice can be installed from side to side in the passageway, with open space near the back. This brattice forces the ventilating air current to the upper portion of the passageway and thus slows down the progress of smoke and flame into the intake air current.

3. Discuss why burning conveyor belts, cable insulation, and tires are particularly hazardous to firefighters.

These materials emit extremely toxic gases as they are decomposed by the fire. Many of these gases are much more dangerous than carbon monoxide. Breathing apparatus should be worn when fighting this type of fire.

4. Discuss other hazards that the rescue team should consider when fighting a mine fire directly.
  - a. Electrocution
  - b. Toxic and asphyxiating gases
  - c. Oxygen deficiency
  - d. Explosive gases
  - e. Heat, smoke, and steam

# Out-of-Control Fires

## Sandfill

In mines that have sandfill available, the sandfill can be used to fight out-of-control fires indirectly. It can be pumped into an enclosed area of the mine to entirely seal it. For instance, sandfill could be pumped into a stope from an existing line or from a borehole drilled from another level. This would work to smother the fire, but it is only used as a last resort.

## Flooding the Mine

Another method of dealing with a fire that is out of control is to flood an enclosed area of a mine. Flooding also is only done as a last resort because it makes any later recovery work difficult in that area.

## Sealing Underground

The purpose of sealing a mine fire is to contain the fire to a specific area and to exclude oxygen from the fire and eventually smother it. Sealing can also be done to isolate the fire so that normal mining operations can be resumed in other areas of the mine. Sealing mine fires underground is a complex issue to which no one set of procedures will apply. Many factors determine the methods used and the eventual success of the sealing operation.

There are two types of seals: temporary and permanent. Temporary seals are often put up before permanent seals are erected in order to seal off a fire area as quickly as possible. Usually permanent seals are then constructed outside the temporary seals to seal off the fire area more effectively.

The map symbol for seal is three straight lines or two straight lines with the word "SEAL" printed after them:

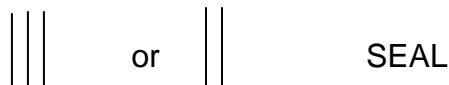

**NOTE TO TRAINER:** Draw these symbols on a chalkboard or flipchart, if possible.

Temporary seals are built to be fairly airtight. They are usually constructed of brattice cloth, concrete blocks, or boards.

Permanent seals are built to be much more substantial and more airtight than temporary seals. They are notched into the back, sides, and floor to make them as sturdy as possible so that they can better withstand the force of an explosion. Permanent seals may be built with concrete blocks and a strong mortar. They can also be made of poured concrete, wood and plaster, or sandfill. **Note:** “Silt” is another term for sandfill.

The officials at the Command Center will decide what types of seals to erect based on all the information they have concerning the fire. Some of the factors that the Command Center considers when planning to seal a fire are:

1. The **amount of explosive gases liberated in the mine or present in the area.** The potential for explosion increases as the explosive gas content increases.
2. The **location of the fire and the area involved.** This determines the number of seals necessary and where they should be placed.
3. The **composition of the overlying strata.** In some mines, the back can be greatly weakened by fire and heat and may be too hazardous for the team to work under.
4. The **building sites for the seals.** These sites are determined by the location of the fire, how fast the fire is spreading, the ability to control ventilation in the fire area, the gas conditions present, and the volatility of the material burning.

In urgent situations, seals, especially temporary seals, are built with the materials that are readily available.

In short, the Command Center decides where, approximately, to build the seals, what materials to use, and in what order to build the seals if more than one is needed. As for the team’s responsibilities in sealing, it’s up to you to pick the exact site within the designated area for building each of the seals and to do a good job in constructing the seals.

When picking an exact site for temporary seals, you should look for (1) good ground conditions, and (2) even back and side surfaces. When building a temporary seal, it should always be built far enough into the passageway to allow enough room and good ground outside it for a permanent seal to be built. If the only site available for sealing has bad ground conditions, you may have to scale it and support it with timbers before beginning to build the seal.

Temporary seals can be built using:

- Brattice cloth
- Concrete blocks
- Wood

## **Brattice Cloth Temporary Seals**

Basically, there are three ways to erect brattice seals. With one method, the brattice, canvas, or plastic can be attached to the back and sides with nails. The surplus brattice at the bottom is then weighted with timbers or other available loose material to keep the seal closed. The other two methods require nailing the brattice to a framework of posts and boards that are set in a solid and well-squared location. With one method, the brattice is cut and nailed to the framework and to the sides, if possible.

It may be necessary to double or triple the thickness of the material in order to improve the effectiveness of the seal. To more completely seal the bottom, you should shovel loose material along the bottom of the seal. Although a seal of this type will allow a certain amount of air leakage, it is tight enough for most purposes and can be erected in minimal time.

Where time is not a serious factor and a fairly tight seal is required, a more substantial brattice cloth seal can be erected. To build this seal, set posts about one foot from each side and one or more posts in between. Be sure to set the posts firmly on solid ground. Nail boards across the top, center, and bottom of the posts. The boards should extend from side to side and the top and bottom boards should be placed as near as possible to the back and floor.

If the sides are irregular, short boards extending from the top to the center boards and from the center to the bottom boards should be nailed along both sides of the framework. These boards should roughly follow the curvature of the sides.

A piece of brattice cloth, canvas, or plastic should be nailed to the boards. The material should be cut large enough to cover the opening, with a small surplus on the sides, top, and bottom. It may be necessary to double or triple the thickness of the material in order to improve the air tightness of the seal. To close small openings around the edges of the seal, small pieces of boards should be used to push the brattice cloth into all irregularities of the back, sides, and floor and should be nailed into place.

To obtain maximum tightness, it may be necessary to caulk the edges of the seal and to shovel loose material against and along the bottom. With reasonable care, a brattice cloth seal can be constructed that will allow only slight leakage of air.

## **Concrete Block Temporary Seals**

Concrete block seals can be put up fairly rapidly especially if they are laid dry. To lay them dry, the blocks should be built up on a solid bottom, one layer at a time. The last layer of blocks should be wedged between the top of the seal and the back. Caulk the edges of the seal with cement or other suitable caulking material. You should then plaster the seal with cement or other suitable sealing material to make it as airtight as possible.



## Wood Temporary Seals

Various kinds of boards can be used to construct wood seals. Usually, rough boards of various widths and about one inch thick are used. However, if a tighter seal is desired, it is better to use tongue-and-groove boards or shiplap boards. The boards should be nailed horizontally on a framework of side and center posts. The posts should be wedged inward and hitched in the bottom. Also, if possible, a shallow hitch should be dug in the back, sides, and floor. The boards should be fitted snugly into the hitch as the seal is erected.

The boards can be overlapped at the center of the seal if they are too long to fit perfectly. This will eliminate having to saw the boards and will, therefore, save time. If you're using shiplap boards, you should nail them onto the framework, starting from the top and overlapping each board as you work your way down. After the boards have been nailed to the framework, the edges of the seal should be caulked with cement or other suitable caulking material.

If rough lumber is used and sufficient brattice cloth is available, the entire surface of the seal should be covered with a layer of the cloth. If brattice cloth is not available, cracks and holes should be plastered over to make the seal as airtight as possible.

## Air Sampling Tubes

When you build the temporary seals, you should include provisions in some of the seals for collecting air samples from within the sealed area. Pipes with valves on them are used for this purpose—usually quarter-inch copper tubing because it is light and flexible.

This air sample tube can be placed anywhere in the seal. It should extend far enough into the sealed area to get a good representative sample of the air that is close to the fire. Depending on the situation, this can vary from about 40 to 100 feet. The tube can be suspended from the back by tying it to timbers or rock bolts. The number of seals in which air sampling tubes should be placed will depend on the sealed area, the number of seals used, and their positions.

## Ventilation

When building temporary seals, one of the most important things to consider is ventilation. **You should be careful to ensure that there are no abrupt changes in the ventilation over the fire area.** A steady flow of air must continuously move over the fire to carry explosive gases, distillates, heat, and smoke away from the fire.

When sealing a mine fire, the only way to keep the air flowing over the fire area is to leave one intake airway and one exhaust airway unsealed while other airways are being sealed. Then, as a final step, the last intake and exhaust can be sealed simultaneously. This will enable ventilation to continue over the fire area until both seals are completed.

Sometimes two teams are used to simultaneously seal the last intake and exhaust. In cases like these, the teams should be in constant communication between themselves or with a coordinator in order to synchronize the simultaneous construction. Usually, fires are sealed far enough away from the fire so that the heat and pressure in the sealed area do not affect the seals.

## Explosions

If an explosion is likely to occur after the seals have been erected, arrangements should be made to close the last seals **after all personnel are out of the mine**. This can be done by leaving hinged doors (similar to drop doors) that will close automatically in one or more of the seals, usually the last intake seal to be erected.

These doors can be temporarily held open with a counterbalance in the form of a perforated bucket filled with water. The holes in the bucket should be made so that sufficient time will elapse before the water drains from the bucket. This will allow time for the personnel in the mine to reach the surface before the door or doors close to complete the seals.

## Isolation

It is also important to isolate the sealed area from the mine in as many ways as possible. This means that all power cables and water and/or air lines going into the sealed area should be removed or severed from the sealed area. It is also advisable to remove a section from the track or any other conductors leading into the sealed area.

## Permanent Seals

A mine cannot be returned to production until the sealed area of the mine has been closed off with permanent seals. Usually, after temporary seals are erected, a waiting period of about 72 hours is recommended before beginning construction on permanent seals.

Permanent seals are most commonly built out of solid concrete blocks or sandfill, though other material can be used. When using concrete blocks, mortar is used between the blocks, and the entire front of the seal is plastered over. Urethane foam may then be put around the edges to seal any leaks.

Urethane foam is an effective sealant when used around the perimeter of a seal. Urethane foam should never be applied more than one inch thick because of the potential for spontaneous combustion with greater thicknesses.

When using sandfill, two bulkheads are built about 20 to 30 feet apart and the space between the bulkheads is filled with sandfill. All permanent seals should be well-hitched in the back, floor, and sides to make them as airtight as possible.

The type of permanent seals used for sealing a mine fire depends on the materials available, the length of time they are to be used, the necessity for complete airtightness, and the strength required to withstand pressure or crushing. Sturdily built seals are a must because the outward pressure on the seals can be substantial at times.

## **Isolation**

Just as when you seal an area with temporary seals, when you put up permanent seals, the area inside the seals must be isolated from the rest of the mine. This means that all cables, lines, or track that were removed or severed for the temporary seal must also be removed or severed for the permanent seal. Sometimes this work will already have been done for you at the time when the temporary seals were built, so you will not have to take care of it when you build the permanent seals.

## **Air Sampling Tubes**

The permanent seals must also have provisions for collecting air samples from within the sealed area, just as the temporary seals do. If air sample tubes were installed in the temporary seals, it will only be necessary to extend those tubes and valves to the permanent seals if they do not already reach.

## **Taking Air Samples**

After the fire area is sealed, it may be necessary to take air samples of the air that is behind the seal so that the quality of the air can be assessed. The ideal time to collect an air sample is when the sealed area is under positive pressure or “breathing out.”

Pressures within and without sealed areas generally will vary according to temperature and barometric changes. These differences in pressure are usually described as “breathing in” (negative pressure in sealed area), “breathing out (positive pressure in sealed area), or “neutral” (no difference in pressure).

When you collect an air sample, if the sealed area is breathing out, you should let the pressure evacuate the air from the sealed area for a while before getting the sample.

This will ensure that you get a good representative sample of the air that's in the fire area, not the air that's right next to the seal. If the sealed area is breathing in or neutral, you should use an aspirator bulb or small pump to evacuate enough air from the sealed area to ensure that you collect a good representative sample of the air that's in the fire area.

Sometimes, however, seals are situated so far away from the fire that the air near the seals has an altogether different composition from the air near the fire. In these cases, air samples are usually not collected at the seals because they would not be accurate. Instead, a two-inch borehole from the surface or another level to the fire area can be used to obtain air samples.

**NOTE TO TRAINER:** If you need additional information on collecting air samples, refer to the "Air Sampling" section of the *Mine Gases* training module.

**Review questions:** Ask team members the following questions and allow time for them to answer. Discuss the answers with them so they fully understand the material covered thus far.

1. Discuss reasons why a mine fire would be sealed rather than fought directly.
  - a. Attempts to fight directly ineffective
  - b. Insufficient materials to fight directly
  - c. Fire of too great a magnitude
  - d. Ground conditions too dangerous
  - e. Buildup of explosive gases
  - f. Location of the fire
  
2. Discuss why it is recommended that the last intake and exhaust seals be erected and closed simultaneously.

It lessens the possibility of explosive gases building up in the fire area.

3. Discuss why all waterlines, power cables, and track leading into a sealed area should be severed or removed before sealing a fire area.

This practice ensures that the sealed area is *completely* isolated from the other areas of the mine and possible ignition sources.

# Explosions

Explosions are rare in most metal and nonmetal mines. However, the possibility for explosions does exist in some mines, particularly salt, trona, and oil shale mines, which can have the highly explosive methane gas.

## Causes and Effects

**NOTE TO TRAINER:** You may wish to refer again to Visual 1 for an illustration of the fire triangle as you discuss the following section.

Explosions are very similar to fires in terms of what causes them. Just as with a fire, three elements must be present for an explosion to occur: fuel, oxygen, and heat (ignition). The fuel for an explosion can be an explosive concentration of a gas or mixture of gases. An explosion can occur if all three elements are present at the same time. To avoid an explosion, the three elements of the fire triangle must be kept away from each other.

Explosions can cause significant damage. Timbers may be blown out, ventilation controls damaged or destroyed, machinery twisted and scattered, and numerous fires ignited. The other main problems associated with explosions are hazardous ground conditions and spreading fires.

Once an explosion has occurred, there is always the possibility of further explosions. Further explosions are possible because once the ventilation system is damaged from the first explosion, explosive gases can accumulate and be ignited either by fires that have developed or by some other ignition source, such as arcing from a damaged cable.

## Before Going Underground

Before any team begins rescue work in a mine where an explosion has occurred or is suspected of having occurred, make sure that the mine is relatively safe to enter and that as many hazards as possible have been eliminated.

The types of things that you should be concerned about are the same types of things we discussed before when we talked about preparing to go into a mine to explore or to fight a fire:

1. The team should make sure that the main fan is running, that a guard is monitoring the operation of the fan, and that tests are being made at the main exhausts for any gases that may be present in the mine. Ventilation is necessary to prevent the buildup of explosive gases.

Keeping the main fan running will ensure ventilation at least up to the point where underground controls have been damaged or destroyed. Testing for CO and explosive gases in the exhausts is essential so that the teams can be withdrawn if a dangerous situation develops.

2. It is usually recommended that the power to the affected area of the mine be cut off. Arcing from damaged cables is a possible ignition source for further explosions or fires. However, cutting the power will affect any auxiliary ventilation and will affect the operation of any electrically-powered equipment such as a pump. The Command Center will have to take these factors into consideration.
3. The team should also know about any possible ignition sources that may exist underground. This could include battery-operated or diesel equipment that may have been left running. Any fires that developed from an explosion are also possible ignition sources for further explosions.
4. If there are any underground storage areas for explosives, oil and grease, or oxygen or acetylene cylinders, you should know about them.

Most of this information should be available to you during your briefing. However, some of the more specific information can only be obtained by the teams as they advance through the mine during exploration.

## Indications of Explosion and Assessment of Conditions

Very often, an explosion is **suspected** of having occurred in a mine and officials will not know for sure until rescue teams go down into the mine to explore and assess the conditions to see if an explosion really did occur. The first indications that an explosion has occurred in a mine may be reports from miners in nearby sections who felt a sudden movement of air, noticed smoke or dust in the air, or heard the sound of the explosion.

**NOTE TO TRAINER:** Refer to Visual 9 for an illustration of a fan chart as you discuss it below. Use this visual as a PowerPoint, chalkboard sketch, or handout.

Another indication of an explosion may be a jump in the pressure recording chart for the main fan. When rescue teams go into a mine to see if an explosion has occurred, some of the evidence they might find is:

- The presence of afterdamp and toxic and explosive gases in the main exhausts
- Blown out timbers and bulkheads
- Overturned equipment
- Ground falls
- Film of dust on mine rail (May be first evidence of an explosion.)
- Smoldering fires and scorched material

Bulkheads that have been damaged or have blown out should be carefully examined. The direction in which a bulkhead has blown helps to indicate the direction of the force of the explosion. Even if bulkheads are not destroyed, indications of blocks having been moved should be noted.

The initial role of the rescue team after an explosion is normally to explore and assess conditions. Once this is completed, the teams will begin the process of reestablishing ventilation and recovering the mine.

**NOTE TO TRAINER:** Information on reventilation and recovery after an explosion is covered in the *Mine Recovery* training module.

**Review questions:** Ask team members the following questions and allow time for them to answer. Discuss the answers with them so they fully understand the material covered thus far.

1. Discuss the necessary factors that must be present in order for an explosion to occur.
  - a. An accumulation of gas within its explosive range (fuel);
  - b. Sufficient oxygen; and
  - c. A source of ignition (heat)
2. Discuss the chief concerns of a mine rescue team when exploring a mine following an explosion.
  - a. Disrupted ventilation
  - b. Possibility of further explosions
  - c. Possibility of fires
  - d. Damage to energized electrical systems that could be further ignition sources
  - e. Accumulations of toxic and explosive gases
  - f. Hazardous ground conditions
3. Discuss evidence that the exploring team might encounter that would indicate an explosion has occurred in the mine.
  - a. Presence of afterdamp and other toxic and explosive gases in exhaust airways
  - b. Blown out or damaged timbers and/or bulkheads
  - c. Ground falls
  - d. Damage to machinery and equipment (cars off track, machinery out of place or overturned)
  - e. Film of dust on mine rail
  - f. Presence of small fire or fires

[This Page Intentionally Left Blank]



# Fire Triangle

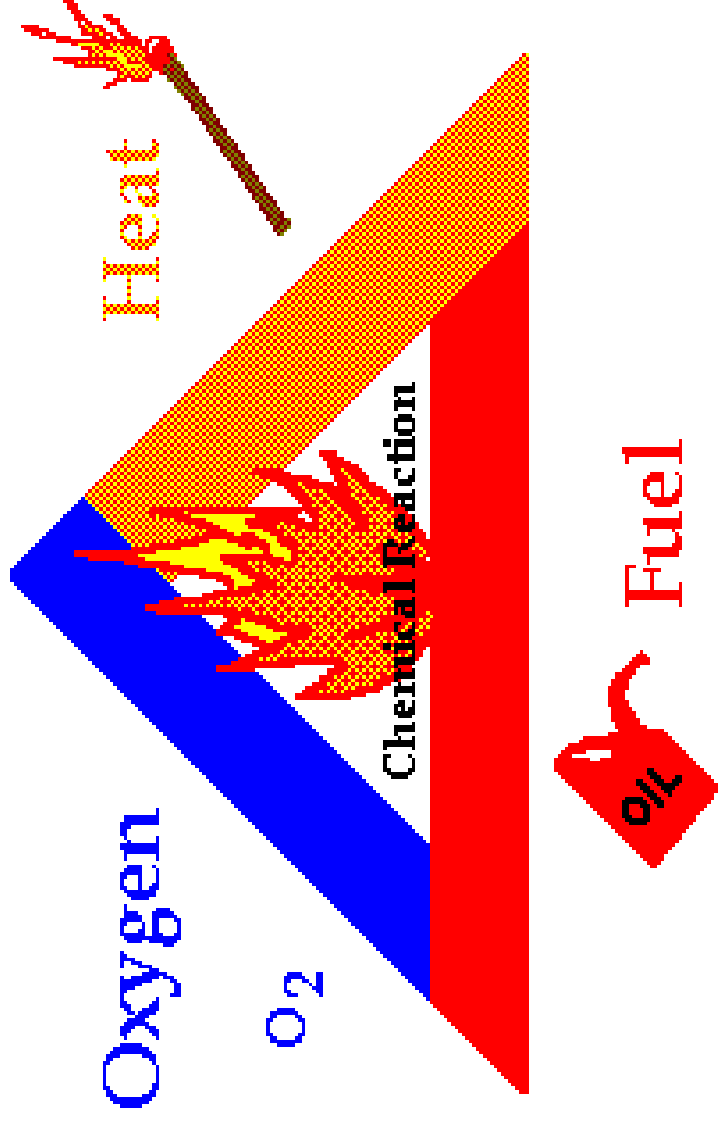

Visual 1

Fire Triangle

[This Page Intentionally Left Blank]

<p><b>A</b></p> <p><b>COMBUSTIBLE MATERIAL</b></p> <ul style="list-style-type: none"> <li>Coal</li> <li>Coal Piles</li> <li>Timber</li> <li>Smoldering Trash</li> <li>Card Board Boxes</li> <li>Wooden Pallets</li> <li>Dry Rags</li> <li>Tires</li> </ul> <p>THE TRIANGLE IS COLORED GREEN</p>	<p><b>B</b></p> <p><b>FLAMMABLE LIQUID</b></p> <ul style="list-style-type: none"> <li>Lubricating Oils</li> <li>Greases</li> <li>Fuel Oils</li> <li>Gasoline</li> </ul> <p>THE SQUARE IS COLORED RED</p>	<p><b>C</b></p> <p><b>ELECTRICAL</b></p> <ul style="list-style-type: none"> <li>Electrical Motor</li> <li>Trolley Wire</li> <li>Battery Equipment</li> <li>Battery Charging Station</li> <li>Junction Box</li> <li>Transformer</li> <li>Circuit Breaker</li> </ul> <p>THE CIRCLE IS COLORED BLUE</p>	<p><b>D</b></p> <p><b>COMBUSTIBLE METAL</b></p> <ul style="list-style-type: none"> <li>Sodium</li> <li>Titanium</li> <li>Zirconium</li> <li>Magnesium</li> </ul> <p>THE STAR IS COLORED YELLOW</p>
---	--	--	--

**Visual 2**

**Four Classes of Fire**

[This Page Intentionally Left Blank]



**Visual 3**

**Using a Hand-Held Fire Extinguisher**

[This Page Intentionally Left Blank]

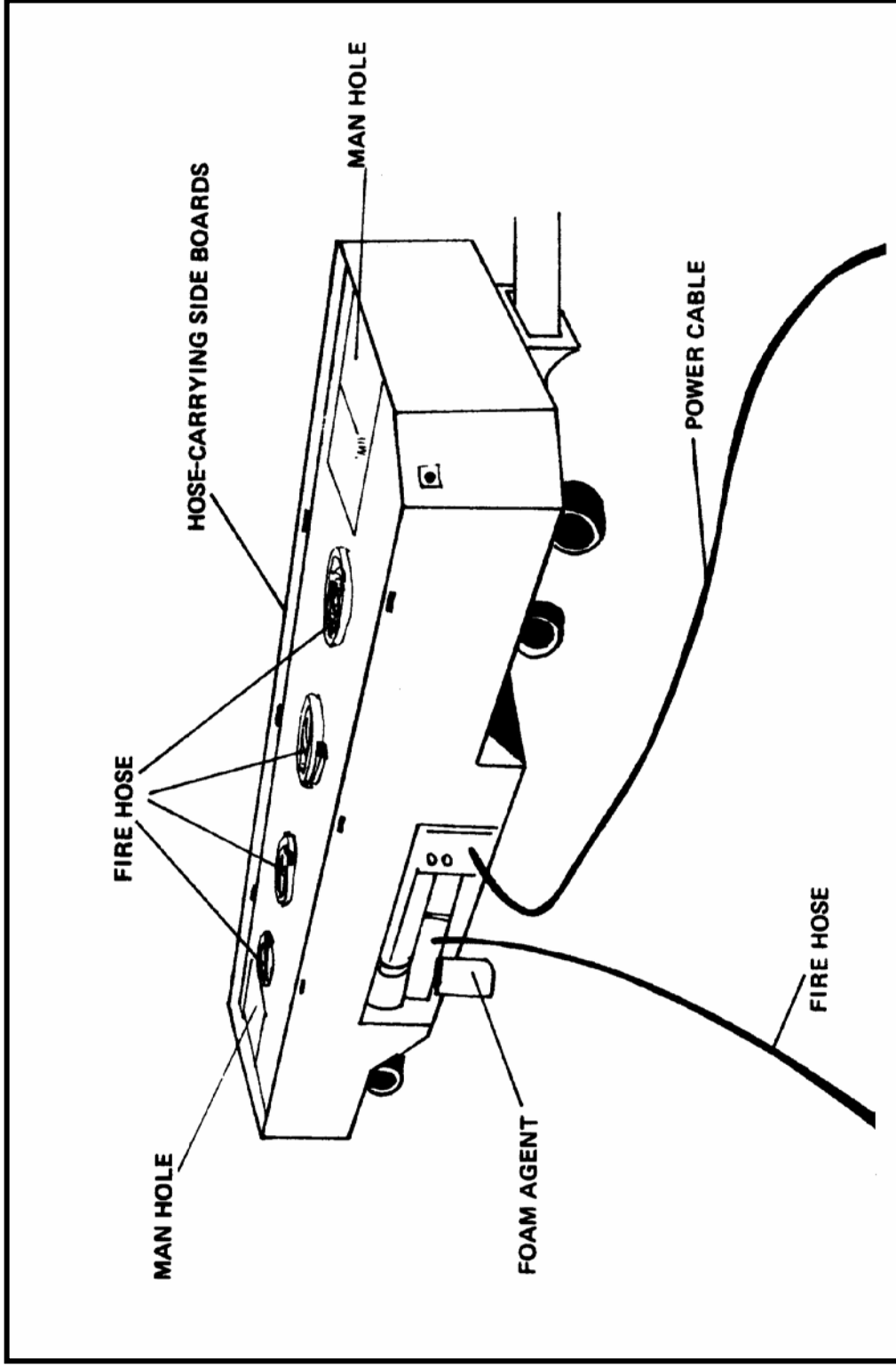

**Visual 4**

**Fire Car**

[This Page Intentionally Left Blank]



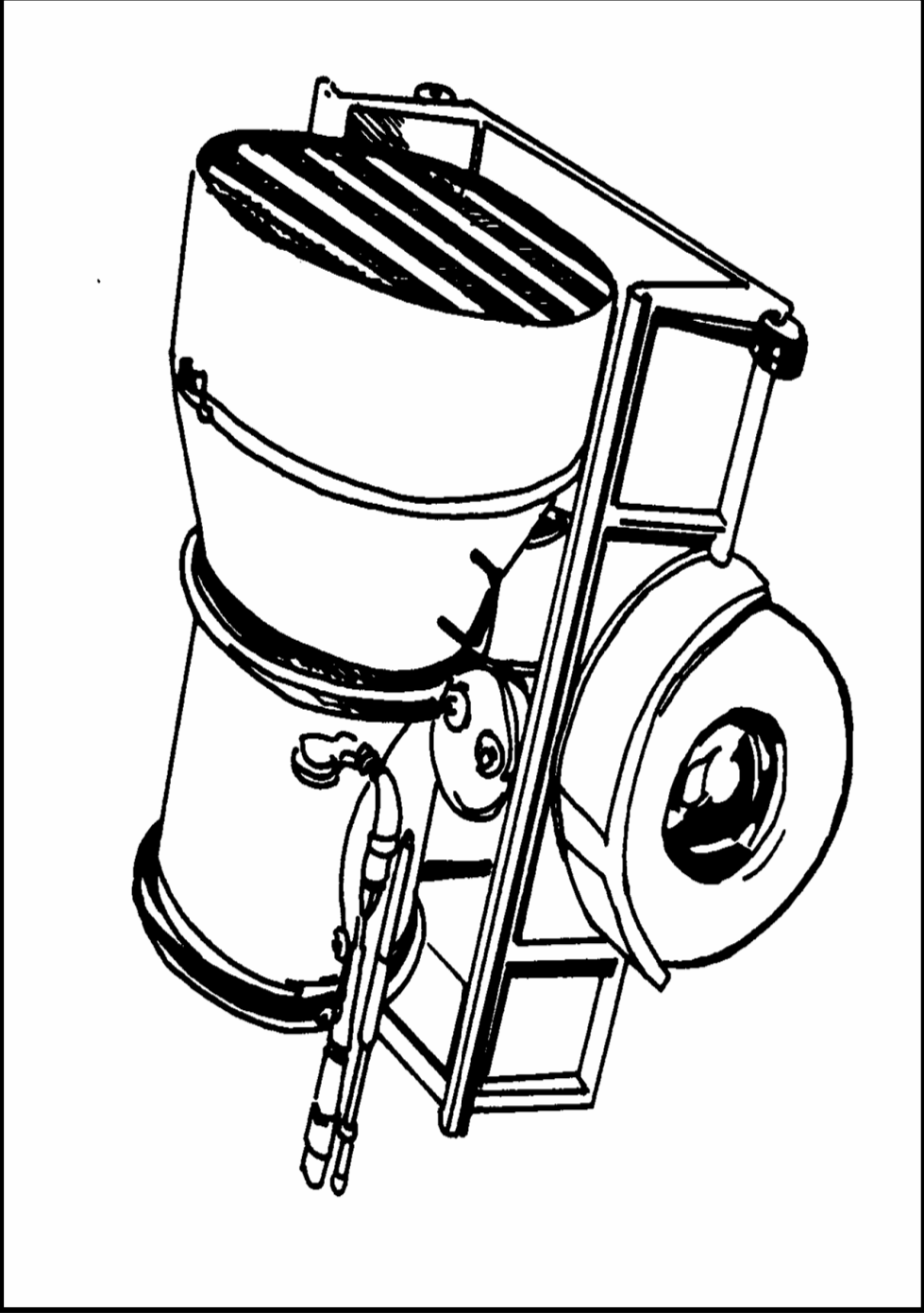

**Visual 5**

**Foam**

**Generator**

[This Page Intentionally Left Blank]

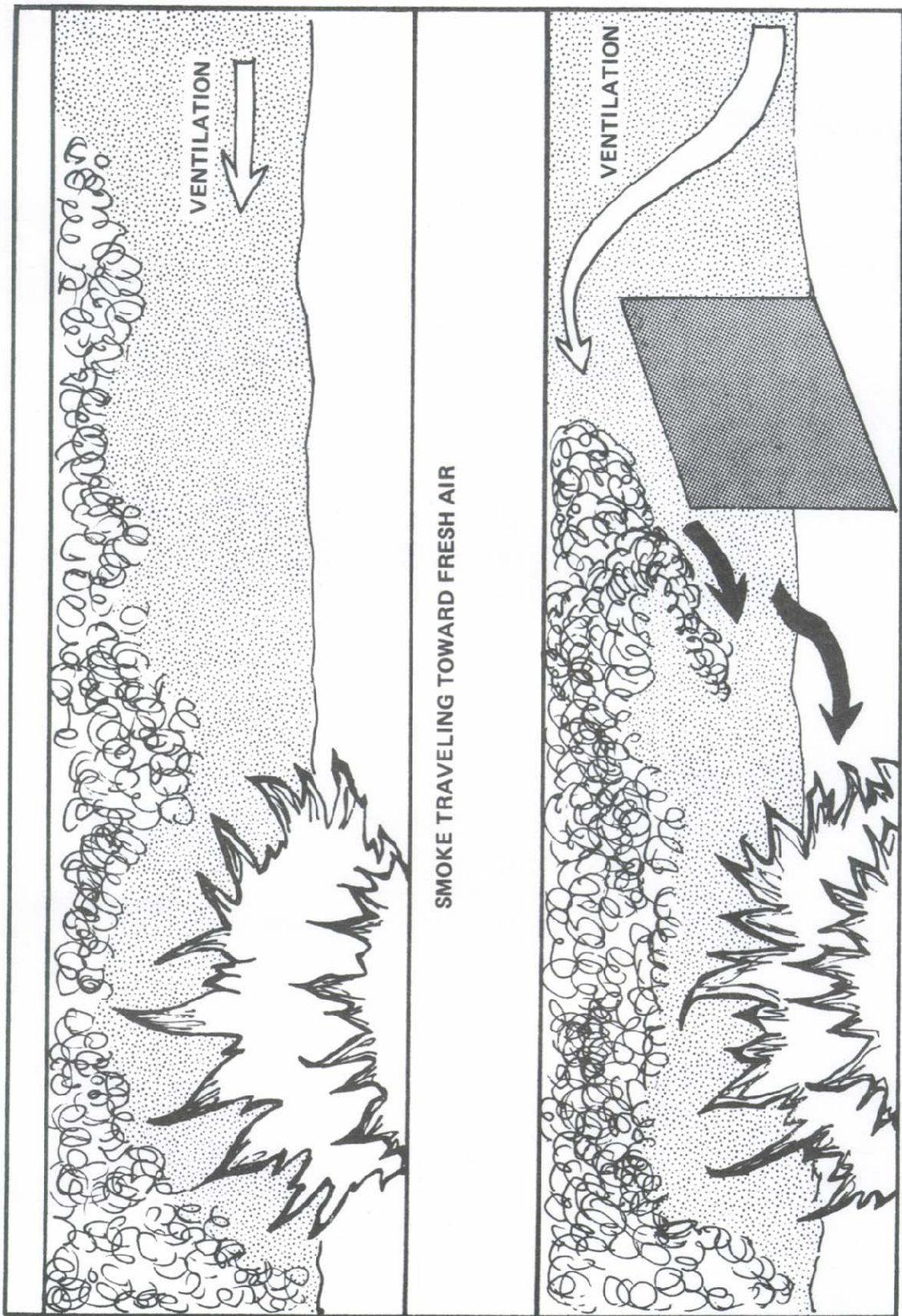

**Visual 6**

**Transverse Brattice**

[This Page Intentionally Left Blank]

# **Hazards of Direct Firefighting**

- **Electrocution**
- **Toxic and Asphyxiating Gases**
- **Oxygen Deficiency**
- **Explosive Gases**
- **Heat, Smoke, and Steam**

**Visual 7**

**Hazards**

[This Page Intentionally Left Blank]

<b>Gases Produced by Burning Rubber, Neoprene, and PVC</b>	<b>Maximum Allowable PPM</b>	<b>Percent</b>
Carbon Monoxide	50	.005
Chlorine	1	.0001
Hydrogen Chloride	5	.0005
*Phosgene	0.1	.00001
Sulphur Dioxide	5	.0005
Hydrogen Sulfide	10	.001
Nitrogen Dioxide	5	.0005
Ammonia	50	.005
Hydrogen Cyanide	10	.001
*Arsine <sup>+</sup>	0.05	.000005
*Phosphine <sup>+</sup>	0.3	.00003

## Visual 8

## Toxic Gases

\*Note the deadliness of these gases as compared to Carbon Monoxide.

+These gases will be found only if the carcass (foundation) is impregnated with certain fungicidal or fire-retardant compositions.

Source: "Investigations into Underground Fires." Safety in Mines Research Establishment, Buxton, England.

[This Page Intentionally Left Blank]



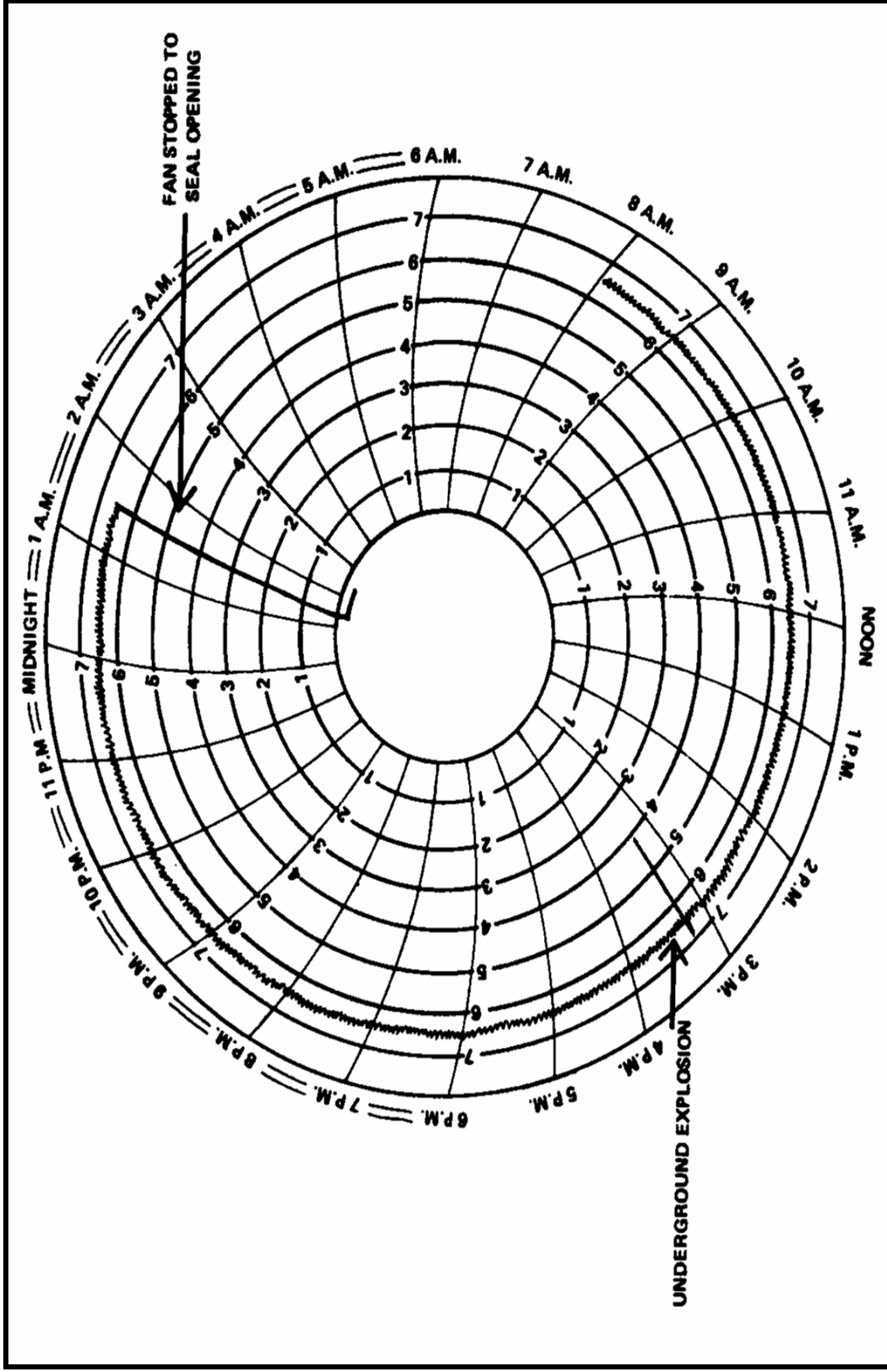

Visual 9

Fan Chart

[This Page Intentionally Left Blank]

## **General Review**

### **Fires, Firefighting, and Explosions**

Have the team members choose the correct answer for each of these questions.

1. Hazards of direct firefighting include all of the following except:
  - a. Explosive gases
  - b. Toxic gases
  - c. Elevated oxygen readings
  - d. Bad ground conditions
2. In sealing a fire it is recommended that:
  - a. Only permanent bulkheads be used
  - b. The last intake and last exhaust be sealed simultaneously
  - c. A single air sample tube be used
  - d. All of the above
3. A positive indication that a fire exists in a mine is:
  - a. Carbon monoxide and/or smoke in the exhaust airways
  - b. Methane and carbon dioxide in the exhaust airways
  - c. Lowered oxygen content in the exhaust airways
  - d. A disruption in normal ventilation
4. Burning materials that give off extremely toxic gases in addition to carbon monoxide are:
  - a. Timbers
  - b. Hydraulic fluids
  - c. Neoprene and other synthetic rubber compounds
  - d. All of the above
5. The preferred type of extinguisher for teams is a dry chemical type that contains:
  - a. Sodium bicarbonate
  - b. Potassium chloride
  - c. Carbon tetrachloride
  - d. Monoammonium phosphate
6. A monoammonium phosphate extinguisher is effective in fighting:
  - a. Class A fires
  - b. Class B fires
  - c. Class C fires
  - d. All of the above

7. Foam generators are effective in controlling mine fires in that they:
  - a. Limit the amount of oxygen reaching the fire area
  - b. Cool the burning materials
  - c. Can be effective when set up long distances from the actual fire
  - d. All of the above
8. When using a dry chemical extinguisher, you should aim the stream of dry chemical:
  - a. Directly at the flame
  - b. Directly at the smoke
  - c. About 6 inches ahead of the flame edge
  - d. About 12 inches ahead of the flame edge
9. Copper tubes or pipes are inserted in temporary and permanent bulkheads for the purpose of:
  - a. Checking for smoke
  - b. Bleeding off excess pressure from the sealed area
  - c. Collecting air samples from the sealed area
  - d. Ventilating the sealed area
10. After an explosion has occurred, the hazards a team might encounter are:
  - a. Spreading fires
  - b. Further explosions
  - c. Weakened ground conditions
  - d. All of the above

General review answers:

1. c
2. b
3. a
4. c
5. d
6. d
7. d
8. c
9. c
10. d

## Glossary

**Class A fires** – Fires that involve ordinary combustible materials such as wood, plastics, paper, and cloth. They are best extinguished by cooling with water or by blanketing with certain dry chemicals.

**Class B fires** – Fires that involve flammable or combustible liquids such as gasoline, diesel fuel, kerosene, and grease. They are best extinguished by excluding air or by special chemicals that affect the burning reactions.

**Class C fires** – Fires that involve electricity. They are best extinguished by non-conducting agents such as carbon dioxide and certain dry chemicals.

**Class D fires** – Fires that involve combustible metals such as magnesium, titanium, zirconium, sodium, and potassium. Special techniques and extinguishers have been developed to put out these fires.

**Direct firefighting** – Method of firefighting where dry chemical extinguishers, water, or foam are put directly onto the fire to extinguish it.

**Fire triangle** – Triangle used to illustrate the three elements necessary for fire to occur: fuel, oxygen, and heat.

**High expansion foam** – Foam used in firefighting that is light and resilient and can travel long distances without breaking down. It is made by mixing water, air, and a high expansion foam concentrate or detergent in a foam generator.

**Hydrogen pops** – Small explosions of hydrogen gas.

**Indirect firefighting** – Method of firefighting where the fire area is sealed or filled with foam, sandfill, or water to exclude oxygen from the fire, and, in the cases of water and foam, to cool the fire.

**Low expansion foam** – Foam used in firefighting that is wet and heavy and, therefore, must be forced directly onto the fire. It is made by mixing a low expansion foam concentrate or detergent with water in a foam nozzle attached to a fire hose.

**Sandfill** – Crushed waste rock that is pumped as slurry and has the consistency of sand when it dries.

**A Guide to  
Mine Rescue Training –  
Metal and Nonmetal**

**Rescue of Survivors and  
Recovery of Bodies**

**Module 6**

# Contents

Course Objectives .....	1
Course Materials .....	1
Course Outline .....	2
Instructor Notes and Suggested Lecture .....	3
Glossary .....	14



# Course Objectives

## Main Objective

To provide the mine rescue team members with recommended procedures for rescuing survivors and recovering bodies following a mine disaster.

## Supportive Objectives

The team members will:

- Describe the factors that help determine the location of possible survivors during a mine emergency.
- Describe the proper procedure for entering a refuge chamber or a barricade behind which survivors may be located.
- Be aware of the possible physical and psychological condition of survivors during a mine emergency.
- Describe the proper procedures for transporting survivors out of the mine.
- Describe the proper procedures for marking locations and identities of bodies that are found.
- Be aware of the possible conditions encountered when recovering bodies following a mine disaster.
- Describe the correct procedures for extricating, disinfection, and tagging bodies, and placing bodies in body bags following a mine disaster.

## Course Materials

Required:

- Pencil and paper for each team member
- Mine Rescue Activity Book

## Course Outline

- I. Introduction
- II. Rescuing survivors
  - A. Locating survivors
  - B. Entering refuge chambers or barricades
  - C. Injured survivors
    - 1. Triage system
    - 2. Psychological factors
  - D. Bringing survivors out
    - 1. Miners found in open areas
    - 2. Miners found in refuge chambers or behind barricades
- III. Body recovery
  - A. Locating the dead and marking the area
  - B. Condition of bodies
  - C. Handling the bodies
  - D. Surviving families

# Instructor Notes and Suggested Lecture

## Introduction

This training session is about how to rescue survivors and recover dead bodies from a mine in which a disaster has occurred. Rescuing survivors might very well be the most rewarding part of your job as a mine rescue team, while recovering bodies is a task everyone hopes they never have to face.

There's little that prepares you emotionally for these two tasks. However, by learning about what you might see and conditions you might encounter during this difficult work, you should be better prepared to handle the situation.

## Rescuing Survivors

### Locating Survivors

Before entering a mine to search for missing miners, there are several questions to which you should have answers.

1. How many miners are missing?
2. What areas were they supposed to be working in?
3. Where are the escape routes in the mine?
4. Where are miners likely to barricade?
5. Are there any refuge chambers located in the area?
6. Are there any ventilation boreholes in the area where miners might go to obtain fresh air?

Survivors may be found in open passageways, perhaps along the escape routes, injured and unable to walk out of the mine. They may be trapped behind falls or other obstructions, or trapped under a piece of equipment or debris. Or, they may be found in refuge chambers or behind barricades.

When you search for survivors, it is important to both **look** and **listen** for clues. Miners who barricade themselves into an area will usually try to leave indications of where they are barricaded to aid rescuers in finding them. For instance, they might put a note in a dinner bucket or draw an arrow along the side or mark a rail to indicate in which direction rescuers should look.

On the outside of the barricade, the trapped miners will probably have written down how many people are barricaded, and the time and date that they barricaded themselves. Another clue to look for would be articles of clothing or possessions, such as the case or cover of a self-rescuer, dropped along the way. While locating something like this would not indicate the direction in which the survivors were traveling, it would show that someone had been in that area.

When **listening** for clues, you should be on the alert for any noise, such as voices or pounding on rails or pipes. When survivors are located, their location, identities (if possible), and condition should be reported immediately to the command center. The command center can then send in a backup team with any equipment that may be needed, such as stretchers or breathing apparatus.

When survivors are located, the location, time, and date should be marked on the team's map and marked on the side in the passageway where they were found.

**NOTE TO TRAINER:** If the team uses a stokes basket instead of a stretcher, be sure to mention it here and elsewhere in the module.

## **Entering Refuge Chambers or Barricades**

When you have located survivors in a refuge chamber or barricade, try to establish communication with them as soon as possible. If you don't get any response, don't assume that the miners are dead; they could merely be unconscious. If you **do** get a response, try to find out how many miners are inside and their condition. Then you will have a better idea of what medical supplies you may need when you reach them. Ask if they have used their self-rescuers, and how long they have been inside.

The safest procedure for getting survivors out is usually to advance fresh air to the refuge chamber or barricade by the quickest means possible. Once the fresh air is advanced, the refuge chamber or barricade can be entered. Sometimes, however, it may be necessary to rescue the survivors before fresh air can be advanced to them. For instance, fresh air cannot be advanced to the survivors if a fire is spreading and moving in their direction. In these cases, an air lock should be established outside the refuge chamber or barricade before it is entered.

The command center will determine whether to advance fresh air or build an air lock. This decision is based on all existing conditions in the area and whatever information is available on the condition of the survivors. If it is decided to establish an air lock, the team will have to build a bulkhead with a flap in it as close as possible to the refuge chamber or barricade.

You should try to keep the air lock small in order to minimize the amount of contaminated air that will enter the refuge chamber or barricade once it is opened. The air lock

should be just large enough to allow all team members to move comfortably and to allow all their necessary equipment, such as a stretcher, to fit in.

Once the bulkhead is constructed, the refuge chamber or barricade can be entered. When entering a barricade, an opening large enough to admit the team members and a stretcher should be made in the barricade and covered immediately with canvas so as to keep the air within it as safe as possible.

## **Injured Survivors**

After survivors have been found in the mine, the next step is to get them to safety and fresh air as quickly as possible. In some cases, survivors may need emergency first aid treatment before they can be transported.

**NOTE TO TRAINER:** First aid procedures are not covered in this module. There are a number of programs already available for teaching first aid. Refer to these programs as needed.

## **Triage System**

When several survivors suffering from physical and/or psychological trauma have been located, the accurate sorting of priority victims may mean the difference between life and death. This sorting of victims is commonly referred to as a “triage” system.

Survivors can be categorized into three priority groups according to their condition or injuries:

1. First priority conditions
  - a. Airway or breathing problems
  - b. Severe bleeding
  - c. Deep shock
  - d. Unconsciousness
  - e. Second degree burns covering more than 30 percent of the body
  - f. Third degree burns covering more than 10 percent of the body or involving hands, feet, or face
  - g. Inhalation of poisonous gases
  - h. Dismemberment
  - i. Chest injuries
  - j. Severe head injuries

2. Second priority conditions
  - a. Multiple lacerations
  - b. Multiple fractures
  - c. Second degree burns involving 15 to 30 percent of the body
  - d. Third degree burns covering less than 10 percent of the body (not including hands, feet, or face)
  - e. Moderate shock
  - f. Moderate heat exhaustion
  - g. Back injuries with or without spinal injuries
  
3. Low or third priority conditions
  - a. Mild hysteria
  - b. Abrasions
  - c. Minor bleeding
  - d. First degree burns of less than 20 percent of the body (not including face, hands, or feet)
  - e. Second degree burns involving less than 15 percent of the body
  - f. Third degree burns involving less than 2 percent of the body
  - g. Fractured arm, hand, or foot
  - h. Mild heat exhaustion
  - i. Obviously dead (DOA)

It is recommended that an emergency medical technician (EMT) be a member of the rescue team, since he or she has the training to determine the extent of injuries, especially if there are several individuals injured. Ideally, the emergency medical service established on the surface should include a physician above ground at the command center. This physician could communicate with the EMT or team member who is attending those injured. This is especially helpful for those victims who need immediate medical attention.

If you find a survivor who has heavy debris on the abdomen, pelvic area, or legs, you must be extremely cautious when you remove that debris. The rescuer must realize that the victim's blood pressure to the critical area has been maintained by the pressure of the debris.

Once the debris has been removed, the victim's blood pressure may drop sharply and death could ensue very rapidly. If you encounter this type of injury, you should request directions from the surface on how to maintain the victim's blood pressure. In all instances, whenever possible, victims should be stabilized before they are extricated.

One thing to remember when dealing with any injury is to stay as calm as possible. Sometimes when faced with a gruesome or unnerving sight, the best thing to do is to take a deep breath and continue to breathe fully and deeply until the job is finished. It helps also to try to concentrate on the fact that what you're doing is a "job" and that "job" is helping someone else to continue living.

## **Psychological Factors**

Psychologically, when survivors are found, their behavior may range from apprehension to uncontrollable hysteria.

The best way to relieve psychological stress in survivors is to try to communicate with them as soon as possible. Most importantly, the communication must be continued. If they lose this communication with the rescue team, they may feel abandoned and try to escape to fresh air even though it is unsafe. If you locate a survivor who is acting irrationally, it may be necessary to restrain him or her in order to protect the person from injury.

**NOTE TO TRAINER:** You may want to mention that there have been instances in the past where survivors have tried to pull off a team member's facepiece. Also, there have been cases where rescue team members have endangered themselves by pulling off their facepieces to give oxygen to a survivor while in bad air.

Whether survivors are showing signs of hysteria or not, they should never be left alone. You should make every effort to assure them that they will be helped. Survivors should never be allowed to walk out on their own even if they appear to be in good shape. They will need your assistance and support in leaving the mine. You may even need to restrain a person to prevent them from "bolting" into fresh air as it is neared.

## **Bringing Survivors Out**

### **Miners Found in Open Areas**

If survivors are found in contaminated or questionable air, they will need to be given breathing protection if they are to be transported to fresh air. If a survivor is able to walk, he or she should be positioned between two rescue team members and guided out to fresh air. If the person is unable to walk, a stretcher will have to be used to bring that person out.

### **Miners Found in Refuge Chambers or Behind Barricades**

If survivors found in a refuge chamber or behind a barricade can walk, they should be provided with the necessary breathing apparatus and assisted to fresh air. If they are unable to walk, they will have to be carried out on stretchers.

When a number of injured survivors are found, a backup team will probably be sent in to expedite the rescue effort and bring everyone out at the same time. Otherwise, the team will have to bring the survivors out on stretchers one at a time.

The procedure for bringing out survivors one at a time is as follows:

- The stretcher should be brought into the refuge chamber or barricade and checked to be sure that it will bear the weight of a person.
- The individual chosen to be brought out first should be given the necessary breathing protection and carefully loaded onto the stretcher.
- The rescue team should then carry the stretcher through the air lock and proceed to fresh air by the shortest and quickest route.
- Every effort should be made during this process to prevent irrespirable air from entering the refuge chamber or barricade.

This procedure for bringing out survivors should be repeated until all miners are brought to fresh air.

**NOTE TO TRAINER:** You could refer to the *Activity Book* for activities related to rescuing survivors.

## Body Recovery

### Locating the Dead and Marking the Area

When a team locates a body, the usual procedure is to report the location to the command center. You should also mark the body's location and position on the mine map and on the side of the passageway where the body is found. It is suggested that a team member outline the body with chalk or paint on the floor, or at least mark the location of the head and feet.

If the floor is too muddy to mark, you should draw the position of the body on a piece of paper or on the mine map. If there is more than one body, usually an identifying number is given to each one. This number should also be marked on the map and on the side of the passageway close to the body.

When a body is first located, every effort should be made not to disturb any possible evidence in the area. Evidence will be important later in ensuing investigations. Usually, the first team that discovers a body is not the team that actually does the body recovery work.



The recovery of bodies may wait until fresh air is advanced or it may be decided to bring the bodies out immediately. Either way, a fresh team will probably be sent in to handle the work.

## Condition of Bodies

Recovering bodies is a job everyone hopes they never have to face. Unfortunately, there's little that prepares rescue teams for what they will be encountering. In some cases, bodies will have no obvious injuries, while others may be badly burned or disfigured, or even dismembered.

If the bodies are not recovered soon after death, they will begin to decompose. In past recovery operations, teams have chosen to use breathing apparatus even when they were working in good air in order to avoid the odor. You should expect to see some very unpleasant sights when recovering bodies. After death, the body goes through various changes and stages of decay.

Some of the factors that influence body deterioration and the changes that occur are:

1. **Air temperature** – A body at freezing temperatures can be preserved for weeks. A body at 70° F (21° C) or higher will decay very rapidly. How quickly the body begins to decay will depend on the temperature in the area.

The parts of a body that are exposed to air will decay faster than the parts that are covered, for instance by clothing. You may find a body lying face up where the face is badly decomposed, but the back of the head which was against the ground still has hair on it.

2. **Body size** – The more muscular the individual, the sooner rigor mortis (rigidity of skeletal muscles) will develop, probably within 4 to 8 hours. The more obese the individual, the longer it will be before rigor mortis will develop, probably within 6 to 10 hours. However, an obese individual will begin the putrefaction (decay) process sooner than a muscular individual.
3. **Body Fluid** – The body is 80 percent liquid. During decomposition, the fluid breaks down and creates gas pressure. Fluid may be forced out of the mouth, nose, ears, or other orifices. Blisters will form under the skin and cause the body to swell up. Some bodies retrieved after a mine disaster have been so swollen that the clothing begins to split.

The body must be handled very carefully or the skin could rupture. If the rescuer is not careful when handling a body, the skin will pull off. In some cases, the skin has actually been pulled off the hand and resembles a hand-like glove, complete with fingernails and creases at the knuckles.

4. **Smell** – There will probably be no decay odor for the first 4 to 8 hours following death. Once the putrefaction process begins, so does the smell. The smell is the result of decay and the gases escaping from the body. When a body is moved, the smell becomes stronger. When the body is brought out of the mine in dry, warm air, the smell is overwhelming.

In general, a body that suffered a great deal of physical trauma, such as a rock fall, will decay faster and have a much worse odor than the body of a person who died from poisonous gases. Further, a body that suffered abdominal or genital injuries will smell worse than the body of a person who had only head injuries.

As long as you wear your self-contained breathing apparatus while recovering the bodies, you will not be affected by the odors. Wearing a handkerchief around your face will not keep out the strong decaying smell.

5. **Body color** – The dead body will turn dark where the blood pools. If the victim is lying face down, the front of the body will be dark. However, if the mine accident is the result of an explosion, the victim may be covered with soot and the discoloration may not be too apparent.
6. **Water, drowning** – If a body is in cold water, it will remain in almost perfect condition for 2 or 3 days. Then it may begin to swell. After taking the body out of the water and exposing it to air, it will begin to decay almost immediately. Most of the time the body will remain under the water for the first 2 days and then it will float. The body floats because of the gases that build up within the body.

These are all very unpleasant things that the team may have to deal with. Some team members will probably be better able to cope with recovering bodies than others. Often in the past, teams composed of volunteers were sent in to do body recovery work. The volunteer crew may be one particular team or it may be made up of team members from different teams.

Rescue workers, especially those recovering bodies for the first time, may very well begin to feel sick or apprehensive. The best advice for you is to try to work with a businesslike and professional attitude. Most of your reactions to the situation will be from your senses of sight and smell. Try to overcome these sensory reactions.

One reaction, however, that may help you is your body's production of adrenaline. Adrenaline is a hormone that is part of the body's natural defense system. It can be produced on a split second's notice and helps one to cope amazingly well with traumatic or frightening situations.

Adrenaline stimulates the heart and increases muscular strength and endurance. So, if you've got a lot of adrenaline flowing, you may find yourself with more strength and courage than you thought you were capable of having.

If you know you can't take it, don't try to bluff your way through. Feeling nauseous with your apparatus on is just not safe. If you are in unsafe air and you vomit into your facepiece, you will not be able to take off your facepiece. So, be honest and let your team captain know if you are experiencing nausea which you cannot control. Keep in mind that even some of the best rescue team members in the past have had difficulty dealing with dead bodies. If you pass out or go down, you become a detriment to your team.

## **Handling the Bodies**

Normally, when bodies are brought out of a mine, they are placed in rubber body bags and brought out on stretchers. If body bags are not available, the bodies can be wrapped in brattice cloth or canvas.

Don't examine the victim's clothing for personal possessions unless you have the team captain's approval. Nothing should be removed from a body except in the presence of witnesses and after a written record is made of the material removed.

Usually, all personal belongings such as a lunch bucket, cap lamp, and self-rescuer, are brought out along with the body. This is important, since miners, especially those that barricaded themselves in, may have written notes to their loved ones on or in their lunch buckets or other personal items.

The location of these items should be marked on the mine map and on the side of the mine near where they are found. Also, if the location and position of the body and the identifying number have not already been marked in the mine and on the mine map, this should be done by the body recovery crew before they remove the body. A tag listing the identifying number and the location where each body was found should be attached to each body bag.

When dealing with bodies that have been underground awhile, you should be sure to wear rubber gloves. Also, the bodies should be sprayed well with a disinfectant before you touch or handle them. This disinfectant will usually be provided for the teams.

One of your main concerns in body recovery work is not to cause further damage to a body in the process of bringing it out of the mine. Bodies recovered shortly after death will not present too many problems because they may not have begun to decompose. Rescuers can lift the bodies by the shoes and armpits and place the victims in body bags. But, with bodies that have begun to decompose, you will have to be extra careful. Trying to put these bodies into body bags will be more difficult.

If you pull on an arm, a leg, or a foot, it may come off because the ligaments, muscles, and tendons have decayed. Part of the skin may remain in the shoe if the shoe comes off. If the leg pulls out of the socket, you may hear a cracking noise. Try to be as gentle as possible with these bodies.

One of the best methods for transferring a decomposed body into a body bag is to gently roll the body onto a sheet of brattice or plastic which is placed next to the body. You can roll the body by using either your hands or a board or something similar. Once the body is on the brattice or plastic, you can easily lift the four corners of the sheet and place the body, along with the sheet, into the body bag.

If you have to straighten limbs that are stiffened by rigor mortis in order to get the body into a body bag, you will have to use some force. Nevertheless, just be careful not to cause unnecessary damage to the body.

In cases where bodies are entangled in debris or buried under falls, the bodies will have to be extricated slowly. Any extrication work that is in close proximity to body parts should be done by hand to ensure that the body is not damaged any further. If you ever find an extra limb or part of a body by itself, put that part in a body bag and mark the bag with what it contains so that it can later be matched with the correct body.

## **Surviving Families**

Recovering bodies is a grim task for rescue workers, and even worse when there had been some hope of finding the miners alive. Teams should realize, though, that for the spouses and other family members involved, it is important to be able, at least, to bury their loved ones.

Recovering the bodies of the dead provides some emotional closure to the stress of the family members. It allows for a funeral, through which there can be communal recognition of the passing of a loved one.

It is important also for legal and insurance reasons. Without a body, a family would have to petition the court to have the person declared dead so that any necessary legal or insurance proceedings could go forward. To this extent, then, teams involved in body recovery can feel that their efforts help to ease the suffering and pain of the waiting families.

**Discussion questions:** Discuss the following questions with the team members. After you have discussed the questions, allow some time for the team to ask questions or just vent feelings and apprehensions about rescuing survivors or recovering bodies from the mine.

1. Discuss the possible clues that would aid the mine rescue teams in locating survivors during a mine emergency.
  - a. Notes left in lunch buckets
  - b. Arrows drawn on side of rail
  - c. Pounding sounds on a rail or pipe
  - d. Self-rescuer covers or cases, or discarded self-rescuers
  - e. Miner's personal items left or discarded
2. Discuss important information that the mine rescue team should be supplied with while being briefed when miners are missing during a mine emergency.
  - a. Number of missing miners
  - b. Area or areas where they were working
  - c. Escape routes used from those areas
  - d. Likely places where miners would erect barricades
  - e. Location of any refuge chambers
  - f. Location of any ventilation boreholes where miners could obtain fresh air
3. Discuss the procedures a rescue team would employ to enter a refuge chamber or barricade behind which miners are located.
  - a. Try to establish communication with the miners.
  - b. If possible, advance fresh air to the area.
  - c. If Step 'b' is not possible, erect an air lock before entering the refuge chamber or barricade.
  - d. When opening a barricade, use as small an opening as possible, and cover the opening with a flap to prevent contamination of the atmosphere.
4. Discuss the usual procedure when a body is encountered during exploration.
  - a. Report location of the body to the command center.
  - b. Mark location and position of body on map.
  - c. Mark location in mine.
  - d. Attach identifying number to body bag.
  - e. Remove nothing from the body or surrounding area.
  - f. Keep all personal belongings of the miner with the body.

## Glossary

**Air lock** – An area in the mine closed at both ends by doors or by bulkheads with flaps or doors in them. Used to prevent mixing of different atmospheres while allowing miners to enter and exit.

**Barricade** – Enclosed part of mine to prevent inflow of noxious gases from a mine fire or an explosion. This may be done by doors or by building one or more airtight walls using any available material, such as rock, wood, brattice cloth, mud, clothing, etc., so as to enclose a maximum quantity of good air.

**Extricate** – To disentangle.

**Hysteria** – Unmanageable fear or emotional excess.

**Putrefaction** – The decomposition of organic matter by bacteria, fungi, and oxidation, resulting in the formation of foul-smelling products.

**Refuge chamber** – An airtight, fire-resistant room in a mine, used as a method of refuge in emergencies by miners unable to reach the surface.

**Rigor mortis** – The progressive stiffening of the muscles that occurs several hours after death as a result of the coagulation of the muscle protein.

**Trauma, physical** – Injury to living tissue.

**Trauma, psychological** – Disordered psychic or behavioral state resulting from mental or emotional stress or physical injury.

**Triage** – System of assigning priorities of medical treatment to injured people.

**A Guide to  
Mine Rescue Training –  
Metal and Nonmetal**

**Mine Recovery**

**Module 7**

## Table of Contents

Course Objectives.....	7-1
Course Materials.....	7-1
Course Outline.....	7-2
Instructor Notes and Suggested Lecture.....	7-3
Visuals .....	7-15
Glossary.....	7- 27



# Course Objectives

## Main Objective

The mine rescue team will be able to effectively participate in a recovery operation after a mine disaster.

## Supportive Objectives

The team members will:

- Identify the procedures for reestablishing ventilation after a mine disaster.
- Identify the supplementary work necessary to restore a disaster area to normal operation.

# Course Materials

Required:

- Handouts and visuals from the back of this module
- Pencil and paper for each team member
- Mine Rescue Activity book

Suggested:

- Laptop computer
- PowerPoint program
- Chalkboard or flipchart

## Course Outline

- I. Introduction
- II. Assessing conditions
- III. Reestablishing ventilation after a fire or explosion
  - A. Unsealing a fire area
    - 1. When to unseal
    - 2. Preconditions for opening a sealed fire area
    - 3. Preparations for opening a sealed fire area
    - 4. Methods of unsealing
      - a. Recovery by progressive ventilation
      - b. Recovery by direct ventilation
  - B. Reventilation after an explosion
    - 1. Considerations
    - 2. Using progressive ventilation
- IV. Clearing and rehabilitating the affected area
  - A. Ground control
  - B. Pumping water
  - C. Clearing roadways and track
  - D. Loading out falls and hot debris
  - E. Restoring power
  - F. Reestablishing the communication system

# Instructor Notes and Suggested Lecture

## Introduction

**Note:** Specific procedures and methods of mine recovery are determined by the needs of an actual recovery operation. This module gives mine rescue team members a general overview of what those methods and procedures are, and a basic explanation of what a recovery operation involves.

Because of the large diversity of minerals and ores mined in metal/nonmetal mines and the diversity of mining techniques used, terminology will vary somewhat from operation to operation. Consequently, the mining terminology used in this training module may not agree completely with the terms used in your area. Therefore, you may need to adapt and change some terminology to suit the needs of your team. For example, in some mines, the term “back” (used throughout this module) will have to be changed to “roof.”

Also, metal/nonmetal operations vary from multi-level mines to single-level, room-and-pillar mines. There will be references in the lecture to each type of operation and sometimes separate visuals. Use the material that applies to your operation.

The main objective of recovery work is to put the mine or affected area of the mine back in operation as soon as conditions permit after a mine disaster. Depending on the conditions, recovery operations can range from a few days work reestablishing ventilation in a small area to many months of costly re-ventilation and rehabilitation work throughout an entire level or section of the mine.

Your role as a mine rescue team member in recovery work varies as the operation progresses and conditions change. Until ventilation is reestablished in the affected area, apparatus crews will be needed to assess conditions, rebuild bulkheads, and, where necessary, clear debris and stabilize ground conditions.

Once ventilation has been reestablished and fresh air is advanced, non-apparatus crews can take over the rehabilitation and clean-up effort.

## Assessing Conditions

In order to plan a recovery operation, there must be an initial assessment of underground conditions. Then, as the work progresses, rescue teams will be updating reports on the conditions and damages they encounter. Assessment of conditions is necessary for your team's safety and also to determine how much rehabilitation work is needed to recover the affected area.

**NOTE TO TRAINER:** You may want to list the topics covered in an assessment on a chalkboard or flipchart so the team members can follow along with your discussion.

One of the main things your team will be checking is the extent of damage to the ventilation system. This includes checking the condition of each of the ventilation controls and any auxiliary fans and tubing.

As your team explores and reventilates an area, you should be checking gas conditions and ground conditions. You should also check the condition of the track, water or air lines, power lines, and phone line, and look for evidence of flooding, flood damage, and smoldering debris or hot spots in a fire area.

## Reestablishing Ventilation

Reestablishing ventilation and bringing fresh air to an area damaged by fire or explosion is the main task of mine rescue teams in a recovery operation. Once this is done, regular work crews can help with the recovery effort.

If a fire area has been sealed, the team must unseal the area, assess the damage, and repair and rebuild the ventilation system. If the area has not been sealed, reestablishing ventilation is a little easier. It involves simply assessing the damage and making the necessary repairs to reestablish normal ventilation.

In an area damaged by an explosion, the task is the same: assessing damages and repairing ventilation controls. After an explosion, though, a great deal of construction work is usually needed to restore ventilation to proper functionality.

## Unsealing a Fire Area

Unsealing a fire area requires careful planning. Opening seals prematurely can cause a re-ignition of the fire and, in mines with explosive gases, could ignite an explosion. Normally, a step-by-step plan for unsealing a fire area is drawn up by company mine officials with the advice of Federal and, where applicable, state, and union representatives.

While mine rescue team members do not plan the unsealing operation, it is important that you know what the considerations and potential problems are in such an operation.

## **When to Unseal**

Determining the exact time to unseal a fire area is based on the laws of physics and chemistry, as well as on experience and sound judgment. A reasonably accurate analysis and interpretation of the gases present in a sealed area is possible through proper sampling techniques and with the aid of a chemist experienced in this work. In addition to the gas conditions, other factors must be considered when choosing the safest time to unseal a fire area.

**NOTE TO TRAINER:** Refer to Visual 1 for a list of the following factors as you discuss them. Use this visual as a PowerPoint, chalkboard sketch, or handout.

The main factors governing the time for unsealing a fire area are:

1. Extent and intensity of the fire at the time of sealing
2. Characteristics of the burning material and surrounding strata
3. Tightness of the seals
4. Effect of barometric pressure on the enclosed area
5. Effect of temperature on the enclosed area
6. Location of the fire area with respect to ventilation
7. Gas conditions as indicated by analysis of air samples taken from behind the seals. (Usually, the gases analyzed are oxygen, carbon dioxide, carbon monoxide, methane, hydrogen, and nitrogen.)

In addition to analysis of these factors, local conditions, such as the proximity of gas wells to the fire area and the extent of the region under seal, must be considered. Ordinarily, more time will be needed before unsealing a large area than a small area.

## **Preconditions for Opening a Sealed Fire Area**

**NOTE TO TRAINER:** Refer to Visual 2 for a list of the preconditions for unsealing a fire area. Use this visual as a PowerPoint, chalkboard sketch, or handout.

Although each situation is different, experience indicates that no attempt should be made to unseal a fire area until –

1. The oxygen content of air behind the seal is low enough to make an explosion impossible (no matter what the quantity of combustible gases is behind the seal);
2. Carbon monoxide (gas that indicates combustion) has disappeared or nearly disappeared from the air behind the seal; and
3. The area behind the seals has been given enough time to cool so that air introduced during the unsealing operation will not rekindle the fire.

Achieving these goals may be difficult, and it may require a great deal of time.

## **Preparations for Opening a Sealed Fire Area**

**NOTE TO TRAINER:** Refer to Visual 3 for a list of the necessary preparations for opening a sealed fire area. Use this visual as a PowerPoint, chalkboard sketch, or handout.

Opening a sealed fire area requires certain preparations:

1. Adjustments in ventilation should be made so that toxic and explosive gases released from the sealed area are directed into the main exhausts.

Also, checks should be made in the exhaust airways for any possible ignition sources (such as phones or signaling lights) in preparation for moving potentially explosive gases.

2. An observer should be at the main fan to ensure it is operating correctly. If the fan slows down or malfunctions, the teams working underground should be withdrawn immediately.

Also, someone should be monitoring gas levels at the main exhausts. If the fan is electrically driven and exhausting, precautions should be taken so that explosive gases do not come in contact with the fan motor or any other electrical equipment used to operate the fan.

3. Checks should be made to ensure that the electrical power in the sealed area has been cut off before unsealing is begun.

Cutting the power is important in mines with explosive gas accumulations. In some mines, however, cutting the power may not be advisable; if, for instance, it is needed for necessary pumping equipment.

4. All unnecessary persons should be withdrawn from the mine.

## Methods of Unsealing Fire Areas

There are two basic methods that can be used for unsealing a fire area: Progressive, or stage, ventilation, and direct ventilation.

**Progressive ventilation** is the re-ventilation of a sealed area in successive blocks by means of air locks.

**Direct ventilation** is the re-ventilation of the entire sealed area at once.

Progressive ventilation is the most common method of unsealing a fire area in single-level mines, particularly room-and-pillar mines. However, either method can be used.

The advantage of progressive ventilation is that gas conditions can be carefully controlled, and the operation can be halted at any point in which conditions become hazardous. The disadvantage of progressive ventilation is that it is a slow process.

Direct ventilation is the common method of recovery in multi-level mines. Direct ventilation can be accomplished quickly. However, before using direct ventilation, there should be conclusive evidence that the fire has been extinguished.

**NOTE TO TRAINER:** You may wish to remind the team that an air lock is made by building two bulkheads 10 to 15 feet apart. Each bulkhead should have a door or flap in it so that teams can enter and exit the sealed area. One opening in an air lock must be kept closed while the other door is open to prevent mixing of the two atmospheres. The distance of 10 to 15 feet is approximate. The distance should be small to limit the amount of air that could enter the sealed area. However, there must be enough room in the air lock to accommodate the team members and their equipment.

## Recovery by Progressive Ventilation

**NOTE TO TRAINER:** This section applies to single-level, room-and-pillar mines. Omit if it does not apply to the team.

In single-level, room-and-pillar mines, progressive ventilation is the usual method of recovery when the sealed area is large, the fire extensive, or bodies must be removed. With this method, the sealed area is explored and re-ventilated in successive blocks by the use of air locks. As long as conditions remain favorable, the work continues and the entire area can eventually be recovered.

**Air locking operations should never be undertaken until the oxygen content of the air behind the seals has been reduced to at least two percent.**

During progressive ventilation, a certain amount of air will unavoidably enter the area behind the seals. As the work continues, oxygen and explosive gas levels must be carefully monitored, and the operation halted if conditions become dangerous.

Recovery by progressive ventilation is very similar to advancing a fresh air base. But it is usually an even slower operation because of the damage that normally is found in a sealed area. The first step in progressive ventilation is to build a bulkhead at one of the seals on the intake side of the fire area to create an air lock.

**NOTE TO TRAINER:** Refer to Visual 4 for a map showing a sealed area and the first air lock for progressive ventilation. Use this visual as a PowerPoint, chalkboard sketch, or handout.

**Air locking operations should always begin on the intake side of the fire.** Once the air lock is completed and conditions are right for entering the sealed area, a team with apparatus can enter the air lock and break out an opening in the seal. You may have to wait after removing the first few blocks from a seal for the pressure to stabilize. After the seal is opened, an apparatus team or, if necessary, a rotation of teams can enter the sealed area and explore and assess conditions to the point where the next air lock will be built. The distance between air locks is usually between 100 and 500 feet. It depends on the conditions encountered and the amount of construction work that is needed to prepare an area for re-ventilation.

During exploration, the team should note conditions in general. They should take temperature readings and make the necessary tests for oxygen, carbon dioxide, carbon monoxide, and explosive gases. When requested, they should collect air samples. They should also take measurements for the new air lock that will be built and any additional bulkheads that will be needed in parallel passageways to seal the area.

**NOTE TO TRAINER:** Refer to Visual 5 for a map showing the re-ventilation of an area. Point out where bulkheads would be needed. Use this visual as a PowerPoint, chalkboard sketch, or handout.

Once the exploration and assessment is complete, a team or teams can be sent in to construct the first bulkhead of the new air lock and any additional bulkheads needed in parallel passageways to reseal the area. Also, the team will have to prepare the area between the two air locks for re-ventilation. This involves repairing ventilation controls and making the necessary changes to direct the air to an exhaust airway. (Refer again to Visual 5 to point out where changes would be needed.)

Before the team leaves the area being prepared for re-ventilation, a final check should be made for any possible fires. Once the team is out of the area, it can be re-ventilated. Generally, this is done by opening a seal on the exhaust side first, followed by one of the seals on the intake side. (Refer again to Visual 5 to point out which seals would be opened.)



If conditions are good, the rest of the original seals can then be opened. This process of putting up air locks and working through them to explore and re-ventilate an area can be continued until the entire area is recovered.

As the work progresses, frequent tests should be made to determine gas conditions in the sealed area and at the exhausts of the areas being recovered. The main concern is the possibility of an explosion or the rekindling of the fire. After the work has progressed close to the origin of the fire, it may be decided to load out heated materials through the air lock before attempting re-ventilation.

As long as there is every indication that the fire has been extinguished, the final sealed area can be re-ventilated. The gases from this area should be removed as quickly as possible.

## **Recovery by Direct Ventilation**

**NOTE TO TRAINER:** This section applies to both single-level and multi-level mines.

The other method for recovering a sealed fire area is by direct ventilation. With this method, the affected area is recovered and re-ventilated as a whole rather than in successive blocks. This method can be used to recover a small area in a mine or an entire level of a multi-level mine.

If a couple of levels have been sealed, the highest level should be unsealed first. Then the teams can progressively work down to the lower ones. This way teams will not be sent in below unknown conditions. **Before using direct ventilation, there should be conclusive evidence that the fire has been extinguished.**

The first step is to build an air lock at an intake seal. Then an apparatus team can travel through the air lock and enter the sealed area. The apparatus team or, if necessary, a rotation of teams will take temperature readings and test for oxygen, carbon monoxide, carbon dioxide, and explosive gases. The team will probably be asked to collect air samples as well.

After completing their testing and observation of the area, the team will return to the fresh air base. If the conditions are favorable, the unsealing can begin. A seal on the exhaust side should be broken open and the air lock opened to admit air. The area can then be ventilated. Any combustible gases in the main exhaust should, if feasible, be kept below the lowest explosive limit.

**When this method of recovery is being used, be sure that all unnecessary personnel are out of the mine before air is actually directed into the sealed area.** The remaining personnel needed to open the seals should then come out as quickly as possible once the seals are opened.

The time for persons to reenter the mine is governed by the quality of the exhaust air, as indicated by periodic sampling and analysis. The command center will determine when conditions appear safe to reenter the mine. If the sealed area is extensive, it's advisable that a rescue team wearing apparatus be the first to reenter. The team should check for and flush out any standing gases from the fire area.

## Reventilation after an Explosion

The objective of reestablishing ventilation after an explosion is to rid the mine of explosive or potentially explosive gas mixtures and restore normal ventilation and normal amounts of oxygen to all workings without propagating another explosion.

### Considerations

**NOTE TO TRAINER:** Refer to Visual 6 for a list of the following considerations as you discuss them. Use this visual as a PowerPoint, chalkboard sketch, or handout.

1. Concentrations of explosive gases. Are they below, within, or above the explosive ranges?
2. Percent of oxygen present. Will it support life? Is it low enough to prevent another explosion?
3. Are possible sources of ignition being considered and eliminated—electrical power, battery-powered equipment, possible fires and hot spots, sparks from tools and team equipment, etc.?

During re-ventilation work, an observer should be stationed at the main fan to ensure it is operating correctly and to warn the team in case of any malfunction. Also, someone should be monitoring gas levels at the main exhausts.

### Using Progressive Ventilation

**NOTE TO TRAINER:** This section applies to single-level, room-and-pillar mines.

Re-ventilation after an explosion in a single-level, room-and-pillar mine is usually accomplished by progressive ventilation. A fresh air base is set up and bulkheads are built in parallel passageways to isolate the affected area. Then, a team wearing apparatus can enter the affected area through an air lock (the fresh air base) to explore and assess conditions. The procedure is basically the same as unsealing a fire area by progressive ventilation.

As long as conditions remain favorable, teams can go in and build a new air lock, put up any bulkheads needed in parallel passageways, and prepare the area being recovered for re-ventilation. The teams should be sure to make the necessary adjustments to direct air from the re-ventilated area to an exhaust. **While exploring and preparing an area for re-ventilation, teams should be on the alert for and eliminate any possible sources of ignition.**

Once the new air lock is put up and gas conditions are checked, normal ventilation can be advanced to that point by taking down the old air lock and opening an airway to the exhaust so that air can circulate through the area. Teams can continue this procedure until the entire area is re-ventilated. The size of the area re-ventilated each time will depend on the conditions they encounter. Where damage is slight, a team will be able to re-ventilate a large area.

However, a team may only be able to do two or three blocks at a time when the damage is extensive and much work must be done to repair ventilation controls. The re-ventilation process will also be slower where travel is difficult, or where ground conditions are hazardous and require timbering and/or other support.

Once an area is re-ventilated, labor crews working barefaced can normally do any further rehabilitation work that is needed in that area. This frees the apparatus teams to prepare the next area for re-ventilation.

Review questions: Ask team members the following questions and allow time for them to answer. Discuss the correct answers with them so they fully understand the material covered.

1. Discuss the two methods of re-ventilating a sealed fire area, and the advantages and disadvantages of each.

Progressive ventilation and direct ventilation

The advantage of progressive ventilation is that gas conditions can be carefully controlled, and the operation can be halted at any point where conditions seem hazardous. The disadvantage is that it is a slow process.

Direct ventilation is quick, but should only be used if there is conclusive evidence that the fire is out. Direct ventilation must be used if an entire level was sealed.

2. Discuss the three preconditions for opening a sealed fire area.

The oxygen content of the atmosphere in the sealed area should be low enough so that an explosion is impossible. There should be no carbon monoxide, indicating that the fire is out. The sealed area should have cooled enough so that the fire is not rekindled when the area is re-ventilated.

3. What preparations should be made before opening a sealed area?

Adjustments in the ventilation system are needed so that toxic and explosive gases released from the sealed area are directed into the main exhausts. Someone should be observing the operation of the main fan and alert the people working underground if the fan slows down or malfunctions. Also, someone should be monitoring gas levels from the main exhausts.

All electrical power in the sealed area is usually cut off and usually the power in the exhaust airways near the sealed area is cut as well. All unnecessary personnel should be withdrawn from the mine.

## **Clearing and Rehabilitating the Affected Area**

Many times, as the rescue teams advance ventilation, they will also, out of necessity, be doing a great deal of construction and clean-up work. In addition to building and repairing damaged ventilation controls, this can include loading out falls and hot materials, stabilizing ground conditions, pumping water, clearing roadways, repairing air and water lines, and restringing communication lines.

Once ventilation has been reestablished in an area, however, labor crews can take over the bulk of the clean-up effort. Until then, this work must be done by apparatus crews for safety reasons and in order to continue to advance the recovery effort.

### **Ground Control**

Fires, explosions, and other disasters frequently result in weakened ground conditions. Rescue teams will have to carefully assess ground conditions during recovery work. You may find that extensive timbering and cribbing is needed to stabilize conditions prior to advancing ventilation.

### **Pumping Water**

Often in recovery operations, rescue teams will encounter large accumulations of water that must be pumped out. There are two ways of accomplishing this. One way is for the team to advance fresh air to the area and then pump out the water.

If the team needs to clear the area before they have advanced fresh air that far, and if gas conditions permit, they can use non-conducting suction lines with a pump set up in fresh air to pump out the water. When using this procedure, careful analysis should be made of the gas conditions in the area being pumped.

Water soluble gases will be pumped out along with the water. And, if the line loses suction, toxic or explosive gases from the contaminated atmosphere can be drawn out.

When advancing into an area that has been inundated with water, teams should pay special attention to ground conditions. Falls are likely in such areas.

## **Clearing Roadways and Track**

Roadways and track will need to be cleared and restored to use as quickly as possible. Once this is done, it will be much easier to bring in the materials that are needed for the recovery and clean-up effort.

## **Loading Out Falls and Hot Debris**

Many times the most practical means of dealing with debris found during recovery operations is to load it onto ore cars, LHDs, or shuttle cars and haul it from the mine. This is particularly true of heated debris found after unsealing a fire area. In fact, the only practical means of eliminating the possibility of rekindling the fire is to remove the heated material. The material should be wetted down before and during the loading operation.

## **Restoring Power**

Power is usually restored progressively by an electrician as the ventilation is advanced. Once power has been restored in an area, the rehabilitation work can proceed much more efficiently because there will be power for transporting materials, equipment, and workers.

## **Reestablishing the Communication System**

As fresh air is advanced, the mine's communication system should be repaired or a substitute system advanced to aid in expediting the recovery operation.

**Review questions:** Ask the team members the following questions and allow time for them to answer. Discuss the correct answers with them so they fully understand the material covered.

1. Discuss the tasks normally involved in recovering a level or area of a mine following a fire, explosion, or other mine disaster.
  - Reestablishing ventilation
  - Securing hazardous ground
  - Pumping water
  - Clearing falls and debris
  - Loading out hot materials
  - Restoring electrical power
  - Restoring the communication system
  - Restoring track
  
2. Discuss how a mine rescue team could remove standing water from an unventilated area.

If gas conditions permit, the team can pump the water using nonconducting suction lines and a pump set up in fresh air.

Careful tests should be made of the gas conditions before beginning the operation. Water soluble gases would be pumped out along with the water. And, if the line loses suction, toxic or explosive gases from the contaminated atmosphere could be drawn out.

**NOTE TO TRAINER:** Refer to the *Activity Book* for a suggested activity related to recovery procedures.

# **Factors Governing When to Unseal**

- 1. Extent and intensity of fire**
- 2. Characteristics of burning material and surrounding area**
- 3. Tightness of seals**
- 4. Effect of barometric pressure**
- 5. Effect of temperature**
- 6. Location of fire area**
- 7. Gas conditions**

**Visual 1**

**When to Unseal**

[This Page Intentionally Left Blank]



# **Preconditions for Unsealing**

- 1. Oxygen content behind seal low enough to make an explosion impossible**
- 2. Carbon monoxide not present behind seal**
- 3. Area behind seal has had sufficient cooling time**

**Visual 2**

**Preconditions for Unsealing a Fire Area**

[This Page Intentionally Left Blank]

## **Preparations for Opening a Sealed Fire Area**

- 1. Adjust ventilation so toxic and/or explosive gases released from the sealed area are directed into main exhausts. Check exhaust airways for any ignition sources.**
- 2. An observer should be stationed at the main fan to warn the rescue team of any fan malfunctions. Also, someone should be stationed in the main exhausts to monitor gas levels.**
- 3. Cut off all electrical power to the sealed area.**
- 4. Withdraw all unnecessary personnel from the mine.**

**Visual 3      Preparations for Opening a Sealed Fire Area**

[This Page Intentionally Left Blank]

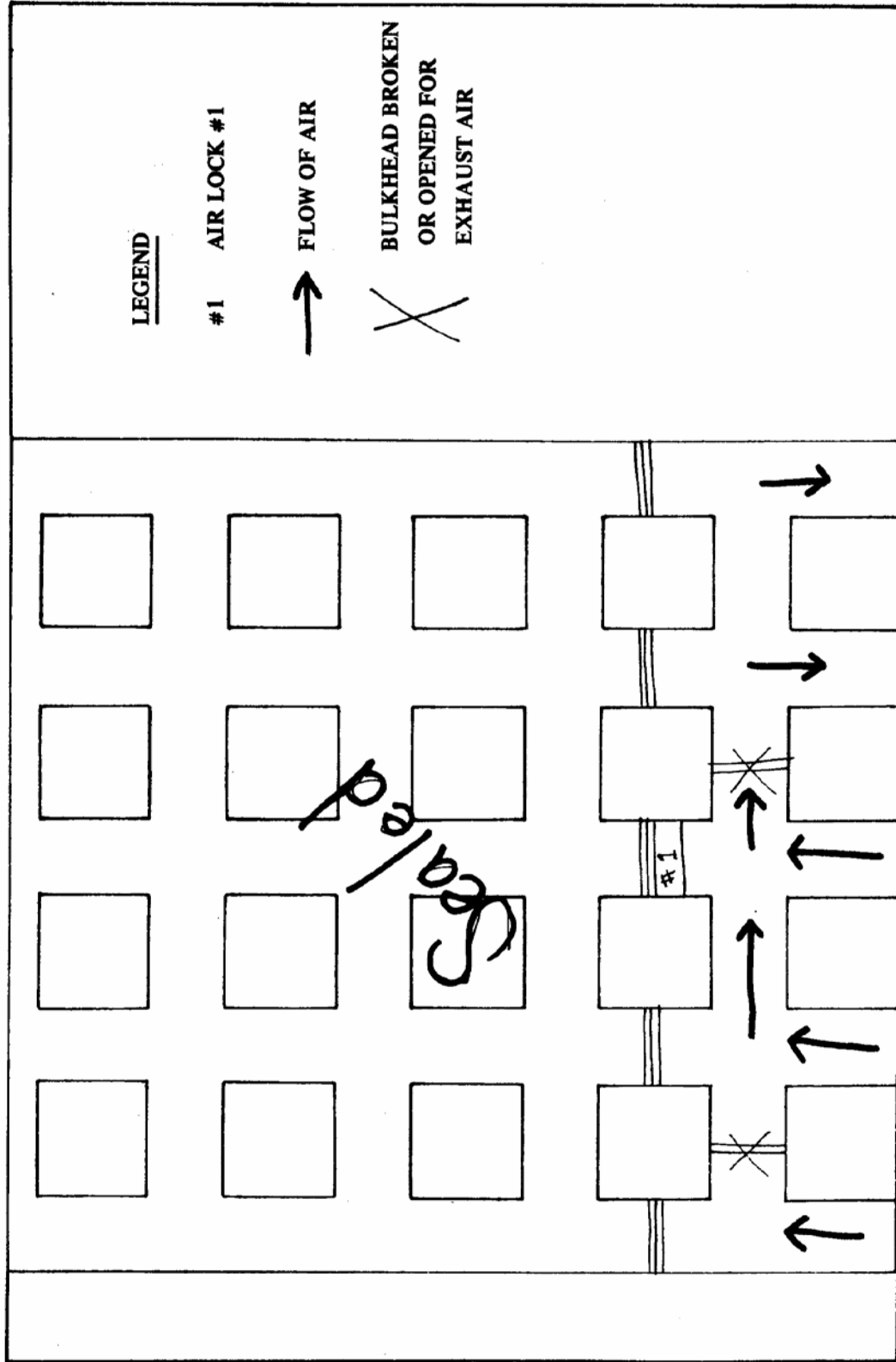

**Visual 4**  
**Sealed Area and First Air Lock**  
**Single-Level, Room-and-Pillar Mine**

[This Page Intentionally Left Blank]

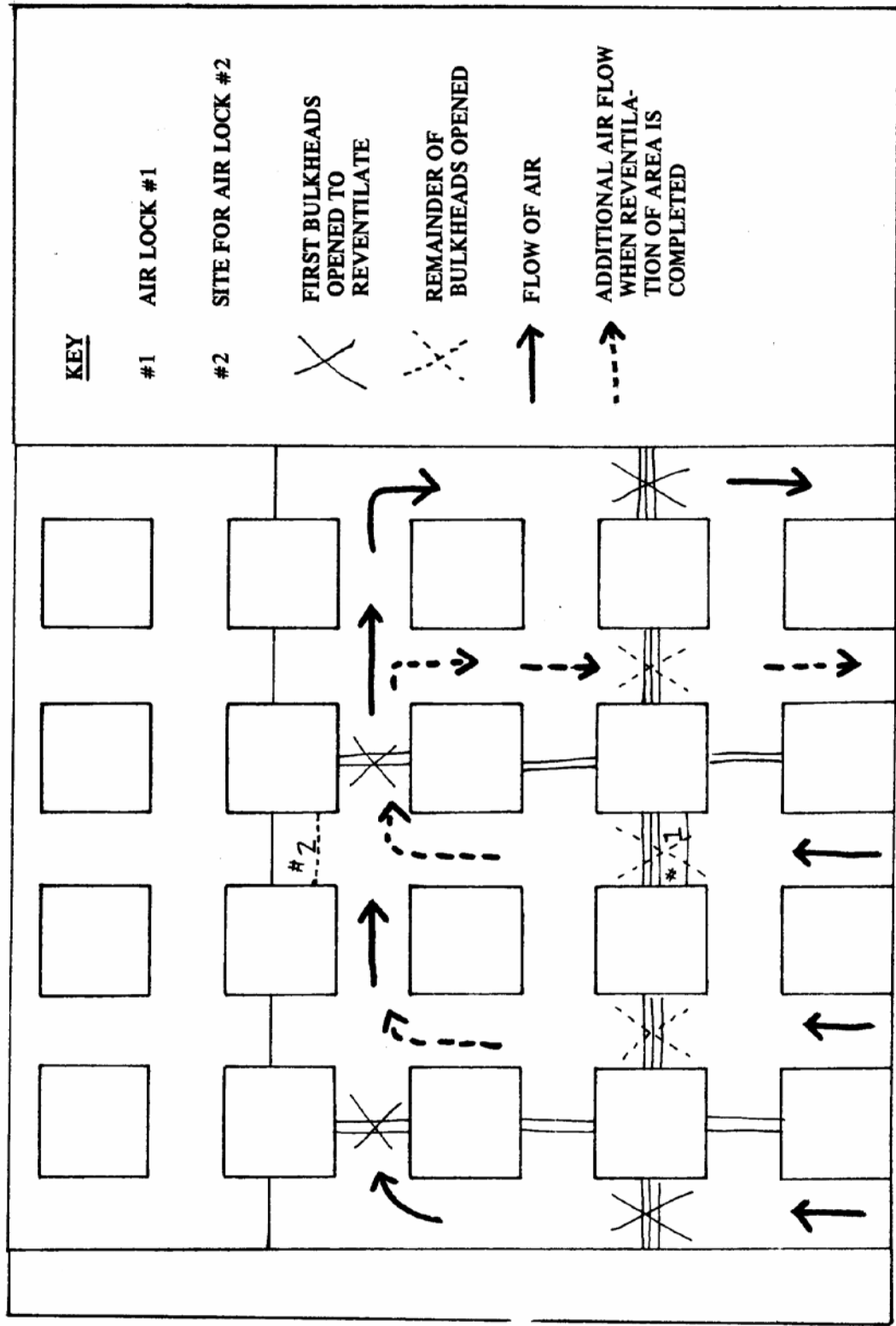

**Visual 5** Re-ventilation of an Area  
Single-Level, Room-and-Pillar Mine

[This Page Intentionally Left Blank]



# **Considerations When Re-ventilating After an Explosion**

- 1. Concentrations of explosive gases**
- 2. Percent of oxygen present**
- 3. Sources of ignition**

**Visual 6**

**Re-ventilating After an Explosion**

[This Page Intentionally Left Blank]

## **Glossary**

**Air lock** – An area in the mine closed at both ends by doors or by bulkheads with flaps or doors in them. Used to prevent mixing of different atmospheres while allowing miners to enter and exit.

**Direct ventilation** – Re-ventilation of the entire sealed area at once.

**Progressive ventilation** (or stage ventilation) – Re-ventilation of a sealed area in successive blocks by means of air locks.

[This Page Intentionally Left Blank]

**A Guide to  
Mine Rescue Training –  
Metal and Nonmetal**

**Mine Rescue Activity Book**

**Module 8**

[This Page Intentionally Left Blank]

## Table of Contents

Introduction .....	8-1
Chart Showing Training Areas Covered in Each Activity.....	8-5
Activity 1 – Using Gas Detectors.....	8-7
Activity 2 – Assessing Gas Conditions .....	8-9
Activity 3 – Interpreting a Ventilation Map .....	8-13
Activity 4 – Using an Anemometer Underground .....	8-15
Activity 5 – Building Temporary Bulkheads .....	8-17
Activity 6 – Practicing Exploration Duties .....	8-19
Activity 7 – Carrying Out an Exploration Assignment.....	8-23
Activity 8 – Using Hand-Held Dry Chemical Extinguishers.....	8-27
Activity 9 – Firefighting Practice Session.....	8-31
Activity 10 – Assessing Fire and Post-Explosion Situations .....	8-33
Activity 11 – Using a Foam Generator Underground.....	8-37
Activity 12 – Using an Air Lock to Rescue a Survivor.....	8-41
Activity 13 – Determining Hazards and Procedures in a Recovery Operation.....	8-45
Activity 14 – Mock Disaster Session.....	8-51

[This Page Intentionally Left Blank]



## Introduction

The Activity Book contains training activities that are suggested for use in conjunction with the Advanced/Refresher Mine Rescue Training Modules. Some of the activities can be integrated into the training lecture where indicated in the modules. Others are full training sessions in themselves and can be used to supplement the module lectures.

The purpose of these activities is to help trainers build competent mine rescue teams. Some of the activities focus on individual team members' ability to perform basic skills, such as operating a piece of firefighting equipment. Other activities focus on the team as a unit—the team's ability to work together successfully under the direction of the captain and to respond appropriately to realistic mine rescue situations and assignments.

Each activity is broken down into its component parts:

- Purpose of the activity
- Type of activity (e.g., underground work problem or classroom discussion)
- Materials needed
- Arrangements to make in advance
- Description of the activity (e.g., directions to team, what to emphasize)
- Evaluation of the activity

The activities will be labeled according to level of complexity. Level 1 activities are the simpler, more basic ones, while Level 2 activities are more complex. A trainer working with a beginning team will find both Level 1 and Level 2 activities useful. With a more experienced team, a trainer might decide to skip some of the Level 1 activities.

The training areas covered in each activity are listed on a chart following this introduction to further aid you in choosing appropriate activities for your team.

## Role of the Team Trainer

In choosing and planning an activity, there are a number of factors that you should consider:

1. Check the stated purpose of the activity. Does the team need practice in this area?
2. Is activity appropriate to the skill level of the team?
3. Should you alter or tailor the activity in any way to make it more useful?
4. Do you have or can you get the equipment needed for the activity?
5. Do you need to make any arrangements for using surface or underground facilities?
6. Will people other than the team members be needed to set up and carry out the activity (e.g., bench person)?
7. How much time will be needed to prepare for, complete, and clean up from the activity? When estimating the time, be sure to include time for:
  - a. Preparing and testing the apparatus (if used)
  - b. Traveling to the area where the activity will be held
  - c. Preparing area for activity (if necessary)
  - d. Completing activity
  - e. Restoring area to original condition after the activity (if necessary)
  - f. Cleaning, recharging, and storing apparatus (if used)
  - g. Critiquing team's performance
  - h. Questions, answers, and discussion

## Evaluating Team Performance

The evaluation is an extremely important part of the learning process. The time spent is not only necessary but vital to the team's development and improvement.

There are three steps for effectively evaluating your team's performance.

1. Observe and record performance.

During the performance of each activity, the team trainer or someone working with the trainer should evaluate the team or the individual team members, whichever is appropriate to the activity. With each activity in the book, you'll find an evaluation section which contains suggestions to help you in evaluating the team's or team member's performance. Sometimes a checklist is included, containing suggested questions to consider in the evaluation.

2. Review the observation results with the team.

This review session should be held as soon as possible after the team has completed the activity. You should go over both the positive and negative aspects of the team's performance. Time should be allowed for team members to ask any questions they might have about the activity or about the trainer's evaluation of them.

3. Recommend future training.

Once the review session is completed, you should begin thinking about the future training needs of the team. Based on what you have observed during the activity, you should be able to recommend areas in which the team needs more knowledge or experience. This might mean reviewing certain information from a module (e.g., team needs more knowledge of SO<sub>2</sub> gas), or it might mean altering a future activity to give the team more experience in a specific area (e.g., communication).

[This Page Intentionally Left Blank]

## Main Training Areas Covered in Each Activity

Activity	Level	Apparatus	Surface Organization	Mine Gases	Mine Ventilation	Exploration	Fires, Firefighting, and Explosions	Rescue of Survivors, Recovery of Bodies	Mine Recovery
#1 Using Gas Detectors	1			✓					
#2 Assessing Gas Conditions	1			✓					
#3 Interpreting a Ventilation Map	1				✓				
#4 Using an Anemometer Underground	2	✓			✓				
#5 Building Temporary Bulkheads	2	✓			✓				
#6 Practicing Exploration Duties	1	✓		✓		✓			
#7 Carrying Out an Exploration Assignment	2	✓		✓		✓			

## Main Training Areas Covered in Each Activity (Cont.)

Activity	Level	Apparatus	Surface Organization	Mine Gases	Mine Ventilation	Exploration	Fires, Firefighting, and Explosions	Rescue of Survivors, Recovery of Bodies	Mine Recovery
#8 Using Hand-Held Dry Chemical Extinguishers	1						✓		
#9 Firefighting Practice Session	2	✓					✓		
#10 Assessing Fire and Post-Explosion Situations	1		✓	✓	✓	✓	✓		
#11 Using a Foam Generator Underground	2	✓					✓		
#12 Using an Air Lock to Rescue a Survivor	2	✓			✓			✓	
#13 Determining Hazards and Procedures in a Recovery Operation	1			✓	✓	✓			✓
#14 Mock Disaster	2	✓	✓	✓	✓	Depending on the problem, one or more of these topics will be included.			

# Activity 1

## Using Gas Detectors

### Level 1

**Purpose:** Team members will develop skill in taking gas readings with portable gas detectors.

**Type:** Classroom or outdoor work problem

**Materials:**

- Gas detectors and extra tubes
- Gas testing boxes, if available, and cylinders of the gases you will be using in the test boxes

**Note:** You can create an oxygen-deficient atmosphere by putting CO<sub>2</sub> in a test box. Use caution when handling gas cylinders.

**Arrangements:** If possible, set up test boxes with the gases to be tested. If you don't use test boxes, have the team members go through the motions of making the tests in normal air.

**Description:** Have team members perform tests for the gases that may be present in the mines they serve and for an oxygen-deficient atmosphere. If possible, have each team member practice operating the testing device. Follow manufacturer's instructions for the proper use of each device.

Emphasize the following during the activity:

1. Proper preparation of detector (zero adjustment, battery check, correct tube, etc.)
2. Proper procedure in taking the reading (proper height, according to specific gravity, and proper use of instrument)
3. Accurate reporting of the findings

**Evaluation:** Use the following checklist to aid you in evaluating each team member's performance. Be sure to list and discuss any problems the team encountered. You may wish to make copies of the checklist for each of the gas detectors used.

<b>Gas Detector:</b>						
Did team member:	#1	#2	#3	#4	#5	#6
1. Prepare testing device properly?						
2. If applicable, use correct detector tube and insert it properly?						
3. Know where to test for gas?						
4. Follow correct procedure in using the detector?						
5. Read the results of the test correctly?						

Comments/Problems:

Recommendations for future training:



## Activity 2

### Assessing Gas Conditions

#### Level 1

**Purpose:** The team will practice identifying the gases that may be present in certain mine rescue situations, and interpreting the hazards that these gases present.

**Type:** Classroom discussion

**Materials:** Gas chart visuals from Training Module 2 *Mine Gases*.

**Arrangements:** *Optional* – Hand out copies of gas charts to team (from *Mine Gases* module.)

**Description:** Describe possible mine rescue situations to the team. You can either make up your own situations or use the sample situations provided below. You may wish to adapt some of the sample situations to be more specific to the team's mine.

Have the team members discuss the situations and determine:

1. What gases are likely to be present as a result of the known conditions.
2. What dangers these gases present.

Be sure to involve all team members in the discussion.

#### Sample Situation 1

An area of the mine has been sealed for several months to extinguish a fire. You go in to unseal the area. What gas conditions might you expect to encounter when reentering the area, and what hazards would these gases present?

**Answers:** Gas conditions:

- O<sub>2</sub> deficiency
- Elevated CO<sub>2</sub> and N<sub>2</sub>
- Elevated CH<sub>4</sub> (if methane is possible in the mine)
- In some mines, H<sub>2</sub>S and SO<sub>2</sub> are possible

Hazards:

- Irrespirable atmosphere
- Opening seals could introduce O<sub>2</sub> and cause a re-ignition of the fire or an explosion
- Although not previously detected, SO<sub>2</sub> and H<sub>2</sub>S could be liberated by pumping or walking through water. Both are toxic.

### Sample Situation 2

A large fire has been burning at a battery charging station for about 10 minutes. What gas conditions might you expect to encounter during firefighting, and what hazards do these gases present?

**Answers:** Gas conditions:

- Oxygen deficiency
- Elevated CO, CO<sub>2</sub>
- Smoke
- Gases from battery charging station (NO<sub>2</sub>, H<sub>2</sub>)

Hazards:

- Irrespirable atmosphere (because of oxygen deficiency, presence of CO and NO<sub>2</sub>)
- Possibility of an explosion (because of elevated CO and H<sub>2</sub>)
- Poor visibility (because of smoke)

### Sample Situation 3

You are told to explore an inactive level. What gas conditions might you expect to encounter, and what hazards would these gases present?

**Answers:** Gas conditions:

- Oxygen deficiency
- Elevated CO<sub>2</sub>, N<sub>2</sub>, and CH<sub>4</sub> (if methane is possible in the mine)

Hazards:

- Irrespirable atmosphere
- Possibility of an explosion

**Sample Situation 4** (For mines where methane is possible)

A methane explosion occurred in a working area. What gas conditions might you expect to encounter in an exhaust airway, and what hazards would these gases present?

**Answers:** Gas conditions:

- O<sub>2</sub> deficiency
- Elevated CO, CH<sub>4</sub>, CO<sub>2</sub>, NO<sub>2</sub>, H<sub>2</sub>, and heavy hydrocarbons (ethane, butane, propane)

Hazards:

- Irrespirable atmosphere
- Possible further explosions

**Evaluation:** Use the following checklist to aid you in evaluating the team's performance. Be sure to list and discuss any problems the team encountered. You may wish to make copies of the checklist for each of the sample situations used.

**Sample Situation #** \_\_\_\_\_

Did team:

1. Correctly identify the gases likely to be present? \_\_\_\_\_
2. Correctly determine the hazards associated with the identified gases? \_\_\_\_\_

Comments/Problems:

Recommendations for future training:

[This Page Intentionally Left Blank]

## **Activity 3**

### **Interpreting a Ventilation Map**

#### **Level 1**

**Purpose:** The team will develop skill in reading and interpreting level or section ventilation maps.

**Type:** Classroom discussion

**Materials:**

- Level or section map showing ventilation (use one from your mine or a sister mine)
- Laptop computer
- Pencils

**Arrangements:** Hand out copies of a level or section map showing ventilation and, if possible, show the map as a PowerPoint.

**Description:** Have team members describe how the air is coursed through the level or section, discussing the use of regulators and auxiliary fans and tubing (if used). Be sure to have them describe how the air gets to and from the mining areas and into the exhaust airways.

After this is done, add a problem to the map that would affect ventilation and have the team members describe how this would change the ventilation. This “problem” could be:

1. An auxiliary fan that’s down, or tubing that’s down.
2. A bulkhead that’s blown out.
3. A ground fall that has obstructed a particular area.
4. A mine door that was left open or that failed to close automatically.

Be sure to involve all team members in the discussion.

**Evaluation:** Use the following list to aid you in evaluating the team's performance. Be sure to list and discuss any problems the team encountered.

Did team:

1. Trace the flow of air through the level or section correctly? \_\_\_\_\_
2. Identify each ventilation control by name and function? \_\_\_\_\_
3. Reinterpret the mine's ventilation correctly after the "problem" (change) was added to the map? \_\_\_\_\_

Comments/Problems:

Recommendations for future training:

## Activity 4

### Using an Anemometer Underground

#### Level 2

**Purpose:** The team will develop skill in taking air measurements with an anemometer and practice working together as a team while under oxygen.

**Type:** Underground work problem

**Materials:**

- Anemometer
- Smoke tube and stopwatch
- Tape measure
- Paper and pencil
- Apparatus

**Description:** Tell the team that they will be going underground to take readings with an anemometer. Emphasize the following in describing this activity:

1. Proper procedure in taking reading
2. Reporting the findings correctly
3. Working under oxygen

Have team members or the bench person prepare the apparatus. When ready, the team should get under oxygen. Have the captain take the team underground to a pre-arranged site to take air readings with an anemometer and to measure the cross-sectional area of the airway. To allow for a longer stay underground, have each team member take a reading.

You should accompany the team. They can report their findings to you as though they were reporting to the command center. If you wish, go ahead and calculate the airflow in cubic feet per minute. The team will probably want to know the final figure.

**Evaluation:** Use the following checklist to aid you in evaluating the team's performance. Be sure to list and discuss any problems the team encountered.

Did team: 1. Pick good location for taking reading? _____ 2. Take area measurements correctly? _____						
Did team member:	#1	#2	#3	#4	#5	#6
1. Hold anemometer correctly?						
2. Stand so as to keep air resistance to a minimum?						
3. Traverse airway properly to get an average reading?						
4. Take measurement for one minute?						
5. Read dials correctly?						
6. Work and breathe well with apparatus on?						
Did captain? 1. Stop for team and apparatus checks when appropriate? _____						

Comments/Problems:

Recommendations for future training:



# Activity 5

## Building Temporary Bulkheads

### Level 2

**Purpose:** The team will develop skill in building temporary bulkheads and will practice working together as a team while under oxygen.

**Type:** Underground work problem

**Materials:**

- Apparatus
- Other team equipment
- Construction materials for building bulkhead
- Tools for building bulkhead

**Arrangements:** Arrange for the use of an area underground and for placement of construction materials at building site or nearby (depending on whether you choose to set up an easier or more difficult problem).

**Description:** Tell the team that their assignment is to build a bulkhead in a specified area. This activity can vary in difficulty depending on the team's experience and how challenging you want to make it.

### Easier Assignment

- Construct a brattice bulkhead
- Materials provided at site
- Work at a slow pace
- Team told exactly where to build bulkhead
- Team should prepare site as necessary before putting up bulkhead

### Harder Assignment

- Construct a brattice or wood bulkhead
- Team must transport materials to site from nearby
- Work at a faster pace
- Team given general area, must pick exact site (for instance, they should choose a spot with good back and even surfaces.)
- Team should prepare site as necessary before putting up bulkhead

Have team members or the bench person prepare the apparatus. When ready, the team should get under oxygen. Have the captain take the team underground to the prearranged site to build the bulkhead. You should accompany the team to observe and evaluate their performance.

**Evaluation:** Use the following checklist to aid you in evaluating the team's performance. Be sure to list and discuss any problems the team encountered.

<p>Did team:</p> <ol style="list-style-type: none"> <li>1. Complete assignment in reasonable time period? _____</li> <li>2. If applicable, transport construction materials to site efficiently? _____</li> <li>3. If applicable, choose good site for building bulkhead (good back, even surfaces, enough room for permanent bulkhead to be built, and so on)? _____</li> <li>4. Prepare site properly? _____</li> <li>5. Efficiently work together as a team? _____</li> <li>6. Construct a tight bulkhead? _____</li> </ol>						
Did team member:	#1	#2	#3	#4	#5	#6
1. Work and breathe well with apparatus on?						
<p>Did captain:</p> <ol style="list-style-type: none"> <li>1. Distribute workload among team members? _____</li> <li>2. Stop for team and apparatus checks when appropriate? _____</li> </ol>						

Comments/Problems:

Recommendations for future training:

## Activity 6

### Practicing Exploration Duties

#### Level 1

**Purpose:** Team members will practice coordinating their individual duties with the team objective of advancing and exploring a specified distance underground.

*Note: This is not a complete exploration assignment, i.e., there is no briefing and no problem involved. The team is simply to practice traveling as a team as well as performing individual duties. The next activity is a complete exploration assignment.*

**Type:** Underground work problem

**Materials:**

- Apparatus
- Team equipment
  - Gas detectors
  - Map and mapboard
  - Communication equipment
  - Scaling bar
- Fresh air base equipment
  - Map
  - Communication equipment

**Arrangements:**

1. Arrange for the team to explore a small area of the mine with an easy terrain.
2. Prepare copies of a map of the area to be explored.
3. At the starting point of the exploration, set up a simple fresh air base with a map and communication equipment.
4. Have someone (perhaps the team alternate) stay at the fresh air base to handle communications and to mark the map.
5. Also, have someone stay at the fresh air base to serve as the communication line, or cable, attendant.

**Description:** Have the team or bench person prepare the apparatus. When ready, the team should report to you with their apparatus and equipment. Give the team's map person a map showing the area to be explored.

The team's assignment is to explore a designated area for about 400 feet, and report and map the conditions they find. The team should advance on intake air (and in single-level mines, tie-in all crosscuts and adjacent entries). Tell the team they will be evaluated on how they function as a team and how they perform their individual duties (such as mapping, gas testing, ground testing, and communications).

The captain should then lead the team to the fresh air base, and have the team members check their equipment and get under oxygen. When the team is ready, let them begin their assignment. You should accompany the team to observe and evaluate their performance. The individuals staying at the fresh air base should stand by, ready to perform their duties.

**Evaluation:** Use the following checklist to aid you in evaluating the team's performance. Be sure to list and discuss any problems the team encountered.

A. Team and Apparatus Checks

1. Did captain check team and apparatus before leaving the fresh air base?  
\_\_\_\_\_
2. Did captain make a first check soon after leaving the fresh air base?  
\_\_\_\_\_
3. Did captain provide a reasonable number of rest stops for the team?  
\_\_\_\_\_
4. Were team and apparatus checks made at each rest stop? \_\_\_\_\_
5. Was the oxygen supply or timer of each apparatus checked at each rest stop? \_\_\_\_\_

B. Traveling Procedures

1. Did team travel in proper order? \_\_\_\_\_
2. Did any team member advance into an area ahead of the team captain?  
\_\_\_\_\_
3. (In single-level mines) Did team "tie-in" as they advanced so they were never forward of an unexplored area? \_\_\_\_\_
4. Did team mark the route of travel? \_\_\_\_\_

C. Testing Procedures

1. Was routine ground testing done by captain? \_\_\_\_\_
2. Were routine gas tests indicated at proper places? \_\_\_\_\_
3. Were tested areas properly marked? \_\_\_\_\_

D. Communications

1. Did captain and co-captain communicate clearly? \_\_\_\_\_
2. Did team members properly respond to all signals and directions?  
\_\_\_\_\_
3. Was talking among team members kept to a minimum? \_\_\_\_\_
4. Were all significant findings reported to the fresh air base? \_\_\_\_\_
5. Were communications with the fresh air base clear and understandable?  
\_\_\_\_\_
6. Did team communicate to the fresh air base frequently enough?  
\_\_\_\_\_

E. Mapping

1. Did team map person note all important findings correctly on the map?  
\_\_\_\_\_
2. Do the team map and the fresh air base map correlate with each other?  
\_\_\_\_\_

F. Overall Team Performance

1. Did team explore full extent of area? \_\_\_\_\_
2. Did team function smoothly under the direction of the captain? \_\_\_\_\_

Comments/Problems:

Recommendations for future training:

[This Page Intentionally Left Blank]

# Activity 7

## Carrying Out an Exploration Assignment

### Level 2

**Purpose:** The team will practice carrying out a realistic exploration assignment from the briefing through the underground exploration to the debriefing.

**Type:** Underground work problem

**Materials:**

- Apparatus
- Team equipment
  - Gas detectors
  - Map and map board
  - Communication equipment
  - Scaling bar
- Fresh air base equipment
  - Map
  - Communication equipment
- Placards (placed underground to indicate various conditions)

**Arrangements:**

1. Arrange for the team to explore an area of the mine that they can cover in two hours.
2. Prepare copies of a map of the area to be explored.
3. At the starting point of the exploration, set up a simple fresh air base with a map and communication equipment.
4. Arrange for someone (perhaps the team alternate) to stay at the fresh air base to handle communications and to mark the map.
5. Also, have someone stay at the fresh air base to serve as the communication line, or cable, attendant.
6. Prepare an exploration briefing. (You can use the two samples provided below as a guide.)
7. Place three or four placards in the area to be explored indicating various conditions, such as smoke, water, a piece of equipment burning, damage to a ventilation control, a fall area, and so on. Choose conditions that will coordinate with the situation you describe to the team in the briefing.

*Note: If you are training two teams, you can alter this activity to utilize both teams. For example, have the second team run the fresh air base while the first team is exploring. When the first team returns to the fresh air base, have them brief the second team. Then, have the second team explore while the first team runs the fresh air base.*

**Description:** Have the team or bench person prepare the apparatus. When ready, the team should report to you with their apparatus and equipment. Give the team's map person a map of the area to be explored, and brief the team on their assignment. Be sure to give them a time limit.

The captain should then lead the team to the fresh air base, and have the members check their equipment and get under oxygen. When the team is ready, let them begin their assignment. You should accompany the team to observe and evaluate their performance. The individuals staying at the fresh air base should stand by, ready to perform their duties. Debrief the team when they return.

### **Sample Briefing for Multi-Level Mines**

At 4:00 p.m., the dispatcher received a report from the underground hoist attendant at the #2 shaft, #9 level, of a possible rockburst. The hoist attendant heard a loud noise and felt a large gush of air in the underground hoist room. He said there was limited visibility in the area.

All miners have been evacuated from the mine, and a fresh air base has been set up at the #2 shaft station, #9 level.

Your team's assignment is to explore and determine conditions on #9 level. Advance as far as you can, but be sure to return to the fresh air base no later than two hours after starting exploration.

There will be a backup team at the fresh air base and a reserve team on the surface. The main fan is operating and the power has been cut to that part of the mine. The CO reading is 600 PPM.

Do you have any questions?

**Evaluation:** Use the following checklist to aid you in evaluating the team's performance. Be sure to list and discuss any problems the team encountered.

#### A. Briefing

1. Did team members ask appropriate questions for the problem? \_\_\_\_\_
2. Did the team members review the map? \_\_\_\_\_

#### B. Preparing to Begin Work

1. Were required checks performed on the apparatus? \_\_\_\_\_
2. Were all members fit to go under oxygen? \_\_\_\_\_
3. Was all team equipment checked? \_\_\_\_\_



C. Team and Apparatus Checks

1. Did captain check team and apparatus before leaving the fresh air base?  
\_\_\_\_\_
2. Did captain make a first check soon after leaving the fresh air base?  
\_\_\_\_\_
3. Did captain provide a reasonable number of rest stops for the team?  
\_\_\_\_\_
4. Were team and apparatus checks made at each rest stop? \_\_\_\_\_
5. Was the oxygen supply or timer of each apparatus checked at each rest stop? \_\_\_\_\_

D. Traveling Procedures

1. Did team travel in proper order? \_\_\_\_\_
2. Did any team member advance into an area ahead of the team captain?  
\_\_\_\_\_
3. Did any team member travel on bad ground? \_\_\_\_\_
4. (In single-level mines) Did team "tie-in" as they advanced so they were never forward of an unexplored area? \_\_\_\_\_
5. Did team mark the route of travel? \_\_\_\_\_

E. Testing Procedures

1. Was necessary ground testing done by captain? \_\_\_\_\_
2. Were appropriate gas tests taken at proper places? \_\_\_\_\_
3. Were tested areas properly marked? \_\_\_\_\_

F. Communications

1. Did captain and co-captain communicate clearly? \_\_\_\_\_
2. Did team members properly respond to all signals and directions?  
\_\_\_\_\_
3. Was talking among team members kept to a minimum? \_\_\_\_\_
4. Were all significant findings reported to the fresh air base? \_\_\_\_\_
5. Were communications with the fresh air base clear and understandable?  
\_\_\_\_\_
6. Did team communicate to the fresh air base frequently enough? \_\_\_\_\_

G. Mapping

1. Did team map person note all important findings correctly on the map?  
\_\_\_\_\_
2. Do the team map and fresh air base map correlate with each other?  
\_\_\_\_\_

H. Overall Team Performance

1. Did team function smoothly under the direction of the captain? \_\_\_\_\_
2. Did team respond properly to each of the placards? \_\_\_\_\_

I. Debriefing

1. Did team make a thorough report on their findings? \_\_\_\_\_
2. Did team go over the map during the debriefing? \_\_\_\_\_

Comments/Problems:

Recommendations for future training:

## Activity 8

### Using Hand-Held Dry Chemical Extinguishers

#### Level 1

**Purpose:** Team members will develop skill in extinguishing a small fire with a hand-held dry chemical extinguisher.

**Type:** Outdoor work problem

**Materials:**

- Dry chemical extinguishers (At least one for each team member plus one as a backup. Additional extinguishers are suggested so that team members can work individually and then with a partner.)
- Metal trough for containing the fire (If you are using a 5-pound multi-purpose extinguisher, you can use a trough 5 feet by 2 feet and about 10 or 12 inches deep. If you are using a 10-pound multi-purpose extinguisher, the trough could be 6 feet by 5 feet and, again, about 10 or 12 inches deep.)
- Fuel for the fire (Fuel oil is frequently used for training fires because it produces heavy smoke. Also, a small amount of kerosene is often added. It will float on the top and is more easily ignited than the fuel oil. In extremely cold weather, you might prefer to substitute gasoline, which has a lower ignition point, for the kerosene.) See the *Arrangements* section for further details on fuel and lighting the fire.
- A safe means of igniting the fire. (You can use a 4- or 5-foot long pole or rod and wrap cloth around one end for a torch. Wire, even a metal hanger, can be used to hold the cloth in place.)
- Matches

**Arrangements:** You want to be sure that you have a safe, controlled fire.

If you are training six team members, you should fill the trough about six inches high with fuel oil (one inch per trainee). This should be enough fuel to last for all six people and should, therefore, eliminate the need to refuel the trough.

**Note:** *If you are training more than six, or you intend to have your team members work individually and then in pairs, you will probably have to refuel the trough. (Refueling is safer than filling the trough with more than about six inches of fuel to begin with. You don't want the fuel too close to the top and possibly boiling over.) To safely refuel the fire, be sure to let the trough cool down before you pour more fuel into it.*

Once you have the six inches of fuel oil in the trough, you can pour on about one-half gallon of kerosene (or, in cold temperatures, gasoline.) To ignite the fire, light the torch, approach the trough holding the torch low, and ignite the fuel. As long as the fuel supply lasts, you can simply relight the fire with the torch after each trainee extinguishes the fire.

One further safety precaution—Make sure the fire area is clear of any flammables. Keep oil drums or fuel containers an adequate distance from the fire so that there is no chance of them heating up and rupturing.

**Description:** Have each team member extinguish the fire. As a safety measure, each firefighter should be backed up by another team member with an extinguisher. After each person has had a turn, you can have the team members pair up and practice putting out the fire with a partner.

In describing this activity, emphasize the following:

1. Proper approach to the fire
2. Proper handling of the extinguisher
3. Proper technique with the extinguisher

**Evaluation:** Use the following checklist to aid you in evaluating the team members' performance. Be sure to list and discuss any problems the team encountered.

Did team member:	#1	#2	#3	#4	#5	#6
1. Approach fire from the proper direction?						
2. Follow correct procedures for operating the extinguisher?						
3. Use proper firefighting techniques?						
• Advance slowly?						
• Aim ahead of the flame?						
• Use side-to-side motion?						
4. Extinguish the fire efficiently?						
5. Back away from fire after fire was extinguished, in case of a flashback re-ignition?						
6. Work efficiently and safely when two worked together?						

Comments/Problems:

Recommendations for future training:

[This Page Intentionally Left Blank]

# Activity 9

## Firefighting Practice Session

### Level 2

**Purpose:** Team members will gain experience in fighting a fire with water while wearing apparatus and under realistic conditions (heat, smoke).

**Type:** Work problem held at a firefighters' training center under the direction (or with the assistance) of an experienced fire trainer.

**Materials:**

- Apparatus
- Firefighting equipment (available from training center)

**Arrangements:** Team members will be better prepared to deal effectively with a mine fire if they have had experience in fighting a fire in heat and smoke conditions. This type of training, though, requires special facilities and is best directed by an experienced fire trainer. It is suggested, therefore, that you make arrangements for your team to participate in a fire training session at a firefighters' training center.

When making these plans, you can specify that you want the team to practice fighting a fire with their apparatus on and working in heat and smoke conditions. (The team should already have some experience in wearing apparatus in smoke.) If the proper facilities are available, you can ask to have your team fight a fire in a confined area to approximate conditions they'd encounter in a mine fire.

**Description:** Explain to the team that this is an opportunity to gain realistic firefighting experience. In describing the activity, emphasize the following:

1. Proper approach to the fire
2. Proper technique with the equipment being used

**Evaluation:** Use the following checklist to aid you in evaluating the team members' performance. Be sure to list and discuss any problems the team encountered.

Did team members:	#1	#2	#3	#4	#5	#6
1. Approach fire from the proper direction?						
2. Use proper technique with the equipment?						
3. Extinguish the fire efficiently?						
4. Back away from fire after fire was extinguished, in case of a flashback re-ignition?						
5. Work and breathe well with apparatus on?						
Did team:						
1. Work together well as a group?						
Did captain:						
1. Stop for team and apparatus checks when appropriate? _____						

Comments/Problems:

Recommendations for future training:



# Activity 10

## Assessing Fire and Post-Explosion Situations

### Level 1

**Purpose:** The team will practice assessing fire and post-explosion situations to determine the hazards present and the procedures that should be followed.

**Type:** Classroom discussion

**Description:** Describe possible mine rescue situations to the team and have them discuss what hazards they might expect to find and what procedures and precautions should be followed. You can use the situations provided below or make up your own.

Be sure to involve all team members in the discussion.

#### Sample Situation 1 (for multi-level mines)

An ore train derailed at an intersection near the 200-level shaft station, and the motor caught fire. The motor crew attempted to fight the fire, but soon realized it was out of control. What are the hazards of this situation and what procedures should be followed before rescue crews go in?

#### Answers:

##### Hazards:

The hazards are that the fire can spread and trap miners working on the 200 level or on levels above and below.

##### Procedures:

1. Evacuate mine completely, if possible
2. Put notification plan into action
3. Cut power from area, if feasible
4. Post guard to monitor continued operation of main fan and to alert command center of any problems with the fan
5. Take gas readings at main exhausts
6. Make plans to send in rescue crews to assess the conditions

## Sample Situation 2

A fire has been burning in a timbered drift for about two hours. The mine has been evacuated, all miners are accounted for, and mine rescue work has begun. The first teams sent in have established the location of the fire and performed the exploration work, including ground testing and gas testing. The command center is sending your team in to fight the fire directly with water. What are the hazards of the situation and what procedures would you follow?

### Answers:

#### Hazards:

The team will be involved in direct firefighting. Team members will have to be wearing apparatus to protect themselves from CO and because of the likelihood of an oxygen-deficiency in the fire area. They will also have to deal with the problems of heat and smoke and the possibility of bad ground conditions and the presence of explosive gases.

#### Procedures:

The team should approach the fire on the intake air side. Even though the last team in the area checked the back and sides and did gas testing, the team fighting the fire should realize that conditions can change quickly. Therefore, they should remain alert to these conditions. Additionally, because the team is fighting the fire with water, there is the potential for a hydrogen buildup. Therefore, intermittent gas tests should be made while firefighting.

Also, the team will want to be sure there continues to be adequate ventilation moving over the fire. This will help dissipate any gases and push the smoke back away from the team. If smoke backs up into the flow of intake air, the team can use a transverse brattice to push the smoke back.

The team should report any changes in ventilation to the fresh air base.

### Sample Situation 3 (for mines where methane is possible)

There are indications that a methane explosion occurred in a working area. What hazards should a team going in be concerned about?

#### Answers:

##### Hazards:

After an explosion, there is the possibility of further explosions and fires. A team should be concerned about gas conditions, about ignition sources, about how adequately the ventilation system is functioning to dilute and carry off toxic and explosive gases, and about the stability of ground conditions.

##### Procedures:

A team going in to explore would want to know that the main fan is running, and that power has been cut from the affected area (if this is feasible). During the exploration, the team should pay particular attention to gas testing and ground testing. Two other priority items would be assessing the condition of the ventilation system and being on the alert for any ignition sources that could cause fires or further explosions.

**Evaluation:** Use the following checklist to aid you in evaluating the team's performance. Be sure to list and discuss any problems the team encountered. You may wish to make copies of the checklist for each of the sample situations used.

#### Sample Situation # \_\_\_\_\_

Did team:

1. Correctly identify the hazards of the situation? \_\_\_\_\_
2. Correctly describe the procedures that should be followed? \_\_\_\_\_
3. Correctly identify the precautions to be taken? \_\_\_\_\_

Comments/Problems:

Recommendations for future training:

[This Page Intentionally Left Blank]

# Activity 11

## Using a Foam Generator Underground

### Level 2

**Purpose:** The team will practice carrying out a mock firefighting assignment using a foam generator.

**Type:** Underground work problem

**Materials:**

- Foam generator
- Apparatus
- Team equipment
  - Gas detectors
  - Map and map board
  - Communication equipment
  - Scaling bar
- Fresh air base equipment
  - Communication equipment
  - Map
- Placards for indicating fire and smoke conditions

**Arrangements:**

1. Arrange to use a development drift underground. This will be the fire area. Choose a spot that has access to water and, if necessary, air lines so that the team can hook up the foam generator.
2. Place fire and heavy smoke placards at the furthest point in the fire area, placards indicating less smoke at the beginning of the fire area.
3. Prepare copies of a map of the fire area.
4. Set up a simple fresh air base 1,000 feet from the fire area on the intake side.
5. Arrange for someone to stay at the fresh air base, handle communications, and mark the map.
6. Also, have someone at the fresh air base to serve as the communication line, or cable, attendant.
7. Make arrangements to have the foam generator situated near the fire area.

**Note:** *You may wish to have the team build a bulkhead and set up the generator in an opening in the bulkhead. If so, you will need construction materials at the site.*

**Description:** Have the team or bench person prepare the apparatus. When ready, the team should report to you with their apparatus and equipment. Give the team's map person a map showing the fire area and their route to the fire area.

Tell the team that the route to the fire area has already been explored. The team's assignment is to advance to the fire area, check current conditions, move the foam generator into position (not too close to the fire) and begin applying foam to the fire. The team should return to the fresh air base no later than two hours after starting their assignment.

The captain should then lead the team to the fresh air base, and have the members check their equipment and get under oxygen. When the team is ready, let them begin their assignment. You should accompany them to observe and evaluate their performance. The individuals staying at the fresh air base should stand by ready to perform their duties. Debrief the team when they return.

**Evaluation:** Use the following checklist to aid you in evaluating the team's performance. Be sure to list and discuss any problems the team encountered.

A. Briefing

1. Did team members ask appropriate questions for the problem? \_\_\_\_\_
2. Did the team members review the map? \_\_\_\_\_

B. Preparing to Begin Work

1. Were required checks performed on the apparatus? \_\_\_\_\_
2. Were all members fit to go under oxygen? \_\_\_\_\_
3. Was all team equipment checked? \_\_\_\_\_

C. Team and Apparatus Checks

1. Did captain check team and apparatus before leaving the fresh air base?  
\_\_\_\_\_
2. Did captain make a first check soon after leaving the fresh air base?  
\_\_\_\_\_
3. Did captain provide a reasonable number of rest stops for the team?  
\_\_\_\_\_
4. Were team and apparatus checks made at each rest stop? \_\_\_\_\_
5. Was the oxygen supply or timer of each apparatus checked at each rest stop? \_\_\_\_\_

D. Traveling Procedures

1. Did team travel in proper order? \_\_\_\_\_
2. Did any team member travel on bad ground? \_\_\_\_\_

E. Testing Procedures

1. Was necessary ground testing done before putting the foam generator in place? \_\_\_\_\_
2. Were appropriate gas tests made in the fire area? \_\_\_\_\_
3. Were tested areas properly marked? \_\_\_\_\_

F. Firefighting Procedures

1. Did the team move the generator into place efficiently? \_\_\_\_\_
2. Was the generator placed in a reasonable spot (not too close to fire or unnecessarily far from fire)? \_\_\_\_\_
3. Did the team hook up the generator to water and foam efficiently?  
\_\_\_\_\_
4. Did the team adjust the water/foam mixture correctly? \_\_\_\_\_

G. Communications

1. Did captain and co-captain communicate clearly? \_\_\_\_\_
2. Did team members properly respond to all signals and directions?  
\_\_\_\_\_
3. Were all significant findings reported to the fresh air base?
4. Were communications with the fresh air base clear and understandable?  
\_\_\_\_\_
5. Did team communicate to the fresh air base frequently enough?  
\_\_\_\_\_

H. Mapping

1. Did team map person note the necessary information on the map (current conditions, placement of generator)? \_\_\_\_\_
2. Do the team map and fresh air base map correlate with each other?  
\_\_\_\_\_

I. Debriefing

1. Did team make a thorough report on their findings? \_\_\_\_\_
2. Did team go over their map during the debriefing? \_\_\_\_\_

Comments/Problems:

Recommendations for future training:

[This Page Intentionally Left Blank]



## Activity 12

### Using an Air Lock to Rescue a Survivor

#### Level 2

**Purpose:** Team members will practice carrying out a rescue assignment that requires using an air lock.

**Type:** Underground work problem

**Materials:**

- Apparatus
- Team equipment
  - Gas detectors
  - Map and mapboard
  - Stretcher and blanket
  - First aid equipment
  - Communication equipment
  - Scaling bar
  - Extra approved apparatus
- Fresh air base equipment
  - Map
  - Communication equipment
- Construction materials for brattice cloth bulkhead
- Tools for building bulkhead

**Arrangements:**

1. Arrange to use a refuge chamber as the barricaded area. (If you do not have a refuge chamber, a bulkhead with a man door could be used as the barricade. Otherwise, you will need a barricade built in preparation for this activity.)
2. Arrange for someone to play the role of an uninjured survivor.
3. Set up a simple fresh air base a distance from the barricaded area.
4. Have someone stay at the fresh air base to handle communications from the team.
5. Also, have someone at the fresh air base serve as the communication line, or cable, attendant.
6. Prepare copies of a map of the barricade area.

**Note:** *In further activities dealing with survivors, you might want to add first aid work. Or, you might want to have the team faced with a survivor who panics and behaves irrationally.*

*Another possible situation is to have the team find three injured survivors behind the barricade. (The team will have to deal with multiple injuries and will have to call the fresh air base for further instructions about transporting the survivors.)*

**Description:** Have the team or bench person prepare the apparatus. When ready, the team should report to you with their apparatus and equipment. Give the team's map person a map showing the barricade and the route of travel to it. Tell the team the area has been explored. Adequate fresh air cannot be advanced to the barricade quickly enough. The team's job, therefore, is to go in, put up an air lock, and bring out any survivors found behind the barricade.

The captain should then lead the team to the fresh air base, and have the team members check their equipment and get under oxygen. When the team is ready, let them begin their assignment. You should accompany the team to observe and evaluate their performance. The individuals staying at the fresh air base should stand by, ready to perform their duties. Debrief the team when they return.

**Evaluation:** Use the following checklist to aid you in evaluating the team's performance. Be sure to list and discuss any problems the team encountered.

A. Briefing

1. Did team members ask appropriate questions for the problem? \_\_\_\_\_
2. Did the team members review the map? \_\_\_\_\_

B. Preparing to Begin Work

1. Were required checks performed on the apparatus? \_\_\_\_\_
2. Were all members fit to go under oxygen? \_\_\_\_\_
3. Was all team equipment checked? \_\_\_\_\_

C. Team and Apparatus Checks

1. Did captain check team and apparatus before leaving the fresh air base?  
\_\_\_\_\_
2. Did captain make a first check soon after leaving the fresh air base?  
\_\_\_\_\_
3. Did captain provide a reasonable number of rest stops for the team?  
\_\_\_\_\_
4. Were team and apparatus checks made at each rest stop? \_\_\_\_\_
5. Was the oxygen supply or timer of each apparatus checked at each rest stop? \_\_\_\_\_

D. Traveling Procedures

1. Did team travel in proper order? \_\_\_\_\_
2. Did any team member travel on bad ground? \_\_\_\_\_

E. Constructing the Air Lock

1. Was necessary ground testing done before putting up the air lock?  
\_\_\_\_\_
2. Was the site prepared properly? \_\_\_\_\_
3. Were building materials transported efficiently? \_\_\_\_\_
4. Did team construct a satisfactory air lock? (If not, what was wrong with it?)  
\_\_\_\_\_

F. Dealing with Survivors

1. Did team try to establish verbal contact with survivor quickly? \_\_\_\_\_
2. Did team keep one opening of air lock closed at all times? \_\_\_\_\_
3. Did team respond to needs of survivor properly? (If not, what should they have done?) \_\_\_\_\_
4. Did team transport survivor safely and efficiently? \_\_\_\_\_

G. Communications

1. Did captain and co-captain communicate clearly? \_\_\_\_\_
2. Did team members properly respond to all signals and directions?  
\_\_\_\_\_
3. Were all significant findings reported to the fresh air base? \_\_\_\_\_
4. Were communications with the fresh air base clear and understandable?  
\_\_\_\_\_
5. Did team communicate to the fresh air base frequently enough? \_\_\_\_\_

H. Mapping

1. Did team map person note the necessary information on the map (air lock, position of survivor, any other findings in barricaded area)? \_\_\_\_\_
2. Do the team map and the fresh air base map correlate with each other?  
\_\_\_\_\_

I. Debriefing

1. Did team make a thorough report on their findings? \_\_\_\_\_
2. Did team go over the map during the debriefing? \_\_\_\_\_

Comments/Problems:

Recommendations for future training:

# Activity 13

## Determining Hazards and Procedures In a Recovery Operation

### Level 1

**Purpose:** The team will practice assessing post disaster conditions to determine the hazards present and the procedures that should be followed in carrying out the recovery work.

**Type:** Classroom discussion

**Materials:**

- Level or section map showing post disaster conditions (Use the one provided or make up your own.)
- Laptop computer
- Pencils

**Arrangements:** Give the team a copy of a level or section map showing post disaster conditions and, if possible, show the map as a PowerPoint.

**Description:** Describe a recovery situation to the team. (You can use the sample provided below as a guide.) Also, give the team a map depicting the situation. Ask the team to discuss the hazards of the situation and what procedures they would follow in carrying out their assignment. Be sure to involve all team members in the discussion.

#### Sample Recovery Situation (single-level mine)

Because efforts to fight the fire directly have failed, an area of a mine has been sealed. The plan is now to reopen the sealed area by means of progressive ventilation. Recent air samples indicated no traces of CO in the sealed area and a low oxygen level.

Look now at the map. Another rescue team has already put up an air lock in No. 4 entry. Your team's assignment is to go in, explore, and assess conditions. Be sure to check all entries and crosscuts and tie-in as you go. Do not advance any farther than two breakthroughs.

1. What hazards might you encounter as you explore the area?
2. How would you advance and what tests should you make as you advance?
3. What conditions should you be reporting on?
4. How many bulkheads are needed to reseal the unexplored area and where should the bulkheads be placed?

## Answers to Sample Recovery Situation

1. The hazards the team might encounter are:
  - a. Toxic or explosive gases
  - b. Weakened ground conditions (because of heat from the fire)
  - c. Hot spots or smoldering material (These could flare up into fires or cause a gas ignition.)
2. The team should tie-in all entries and crosscuts, take temperature readings, test the back and sides, and test for gases as they advance. You may wish to have the team describe in what order they would explore the entries and crosscuts.
3. The team should report on:
  - a. Gas conditions
  - b. Ground conditions
  - c. Condition of all ventilation controls
  - d. Condition of any power lines, communication lines, or air or water lines in the area
4. Eight bulkheads are needed to reseal the unexplored area. (See map on Page 45 for placement of bulkheads.)

**Evaluation:** Use the following checklist to aid you in evaluating the team's performance. Be sure to list and discuss any problems the team encountered.

Did team:

1. Identify all possible hazards? \_\_\_\_\_
2. Indicate all tests they should make? \_\_\_\_\_
3. Indicate all reports they should make concerning conditions? \_\_\_\_\_
4. Describe the procedures they would follow to carry out their assignment?  
\_\_\_\_\_

Comments/Problems/Recommendations:

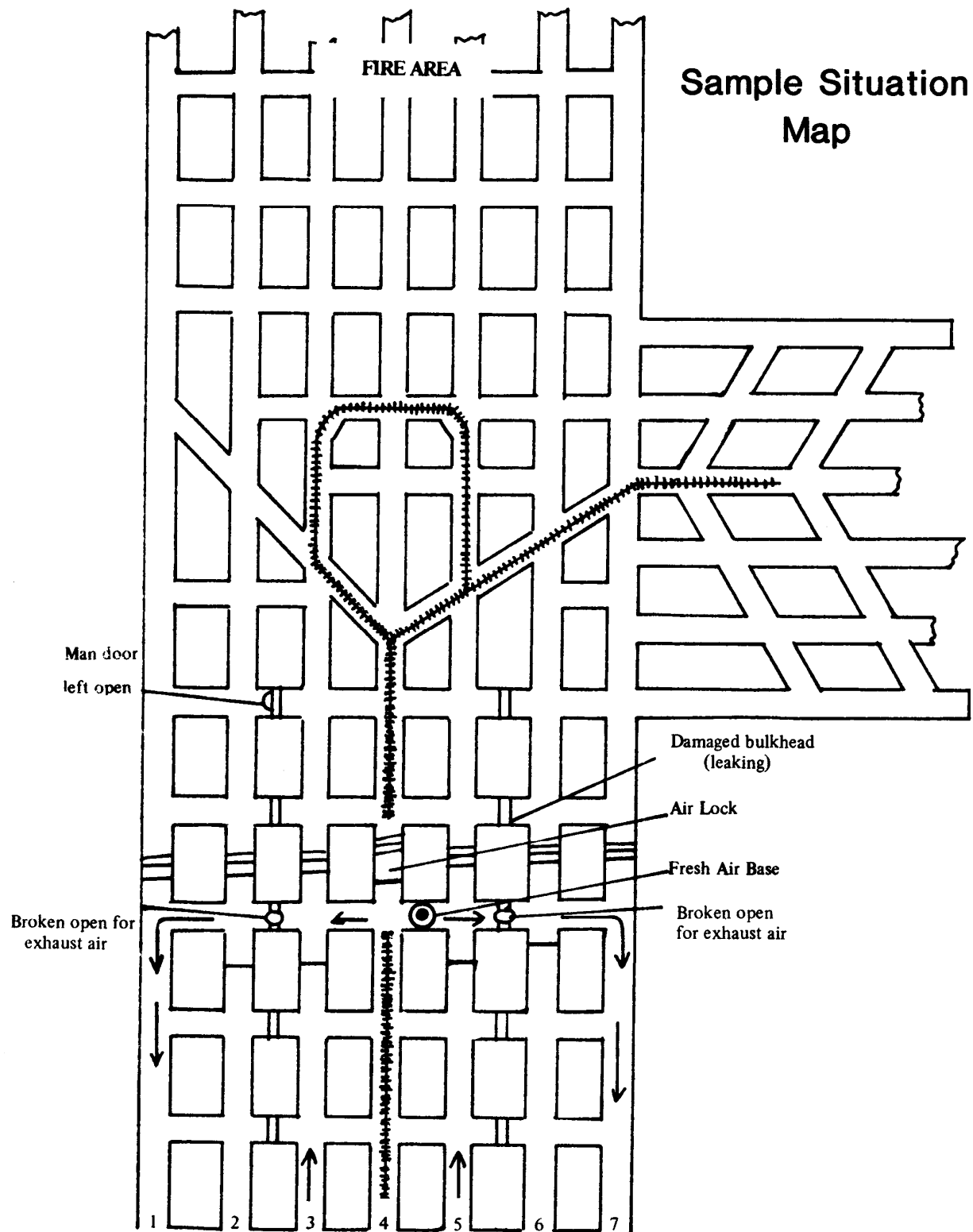

[This Page Intentionally Left Blank]



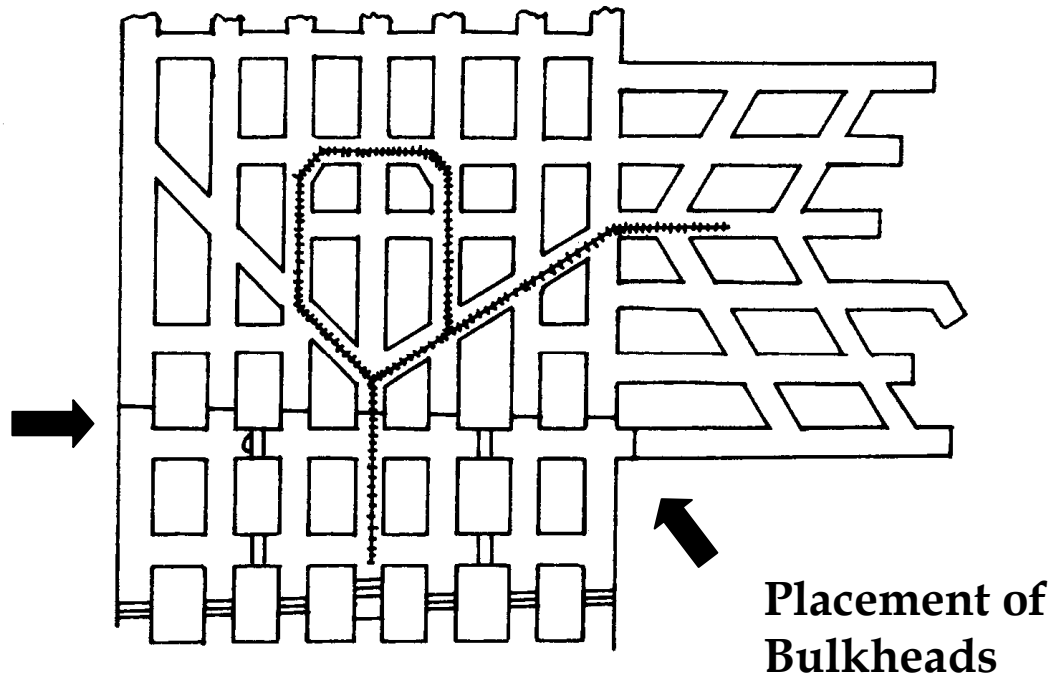

or

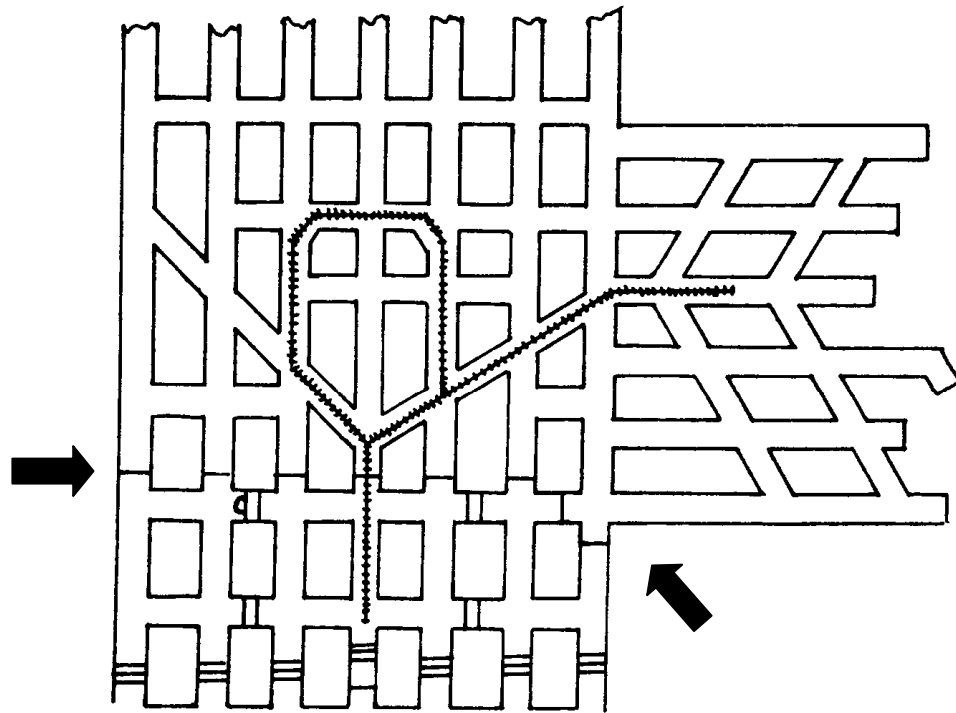

[This Page Intentionally Left Blank]

# Activity 14

## Mock Disaster Training Session

### Level 2

**Purpose:** To provide realistic mine rescue training not only for the teams but for other mine personnel who would be involved in the event of an actual mine rescue situation.

**Description:** A mock disaster is a simulation of an actual mine rescue operation.

**Arrangements:** A mock disaster training session requires setting up a command center, establishing a fresh air base, and deploying teams on a rotation schedule. This idea is not new. A number of companies already use a mock disaster training session as part of their total emergency preparedness training.

The preparations necessary for putting on a mock disaster training session include preparing areas for a command center and a fresh air base (both with necessary communications) and an underground area in which the team will be working (placards can be used to indicate various conditions). You will need to have maps of the underground area, a briefing and team assignments, and a team rotation schedule. In addition, there should be an area set aside for teams to prepare and clean their apparatus.

Personnel needed to carry out the mock disaster include the rescue teams (at least three, although four is probably the optimum number for a single day's training session) and the appropriate safety and management people to man the command center and fresh air base. It's also important to involve other surface personnel who should be called on in a real rescue situation. For instance, you can have guards checking people as they come onto the property, a supply clerk, lamp person, mine electrician, mechanical foreman, etc. (Refer to the *Surface Organization* module for a complete list of personnel and duties.)

You may want to invite MSHA and (where applicable) state officials to observe or participate in the mock disaster. You will need equipment and food for all these participants.

A mock disaster training session requires the participation of quite a few people, particularly, management-level people. While it can be a significant outlay of money and time, a mock disaster training session can also be an extremely valuable training experience. For the teams, it's a realistic training session; and for the people in charge, it's an opportunity to practice coordinating and directing rescue work.

**Evaluation:** Use the following checklist to aid you in evaluating this activity. Be sure to list and discuss any problems encountered.

1. Problems in organization—  
Did people know where to go when they arrived? \_\_\_\_\_
2. Flow of information—  
Was necessary information transmitted smoothly between the command center, the fresh air base, and the teams? \_\_\_\_\_  
Were all communications recorded at the fresh air base and the command center? \_\_\_\_\_
3. Decision-making at the command center—  
Were the necessary people available to provide needed information and to assist in decision-making? \_\_\_\_\_  
Were decisions made efficiently? \_\_\_\_\_
4. Were briefings and debriefings effective? \_\_\_\_\_
5. Did team rotation changes go smoothly? \_\_\_\_\_
6. Did teams perform adequately? \_\_\_\_\_
7. Were conditions at the fresh air base and command center appropriate (too much noise, too many people, too few)? \_\_\_\_\_
8. Did people stationed on the surface outside the command center (i.e., guards, supply clerk, etc.) have any problems carrying out their jobs?  
\_\_\_\_\_  
Did they have access to the information they needed? \_\_\_\_\_

Comments/Problems: You may want to have participants fill out a short evaluation sheet to gather information on the problems and successes of the operation.

Recommendations for future training: